

# Service Guide

## Agilent Technologies PSA Series Spectrum Analyzer

This manual provides documentation for the following instruments:

**E4440A (3 Hz – 26.5 GHz)**

**E4443A (3 Hz – 6.7 GHz)**

**E4445A (3 Hz – 13.2 GHz)**

**E4446A (3 Hz – 40 GHz)**

**E4447A (3 Hz – 42.98 GHz)**

**E4448A (3 Hz – 50 GHz)**

More Application, Information, and Pricing available at:



**TestWorld**

250 Technology Way  
Rocklin, CA 95765

sales@testworld.com  
1-855-200-TEST (8378)

Click to go [www.TestWorld.com](http://www.TestWorld.com)



**Agilent Technologies**

**Manufacturing Part Number: E4440-90616**

**Supersedes: E4440-90590**

**Printed in USA**

**June 2008**

© Copyright 2002-2008 Agilent Technologies, Inc.

---

## Notice

The information contained in this document is subject to change without notice.

Agilent Technologies makes no warranty of any kind with regard to this material, including but not limited to, the implied warranties of merchantability and fitness for a particular purpose. Agilent Technologies shall not be liable for errors contained herein or for incidental or consequential damages in connection with the furnishing, performance, or use of this material.

---

## Safety Information

The following safety notes are used throughout this manual. Familiarize yourself with each of the notes and its meaning before operating this instrument.

---

### WARNING

**Warning denotes a hazard. It calls attention to a procedure which, if not correctly performed or adhered to, could result in injury or loss of life. Do not proceed beyond a warning note until the indicated conditions are fully understood and met.**

---

### CAUTION

Caution denotes a hazard. It calls attention to a procedure that, if not correctly performed or adhered to, could result in damage to or destruction of the instrument. Do not proceed beyond a caution sign until the indicated conditions are fully understood and met.

---

### WARNING

**This is a Safety Class 1 Product (provided with a protective earthing ground incorporated in the power cord). The mains plug shall only be inserted in a socket outlet provided with a protected earth contact. Any interruption of the protective conductor inside or outside of the product is likely to make the product dangerous. Intentional interruption is prohibited.**

---

**WARNING**            **The power cord is connected to internal capacitors that may remain live for 5 seconds after disconnecting the plug from it's power supply.**

---

**WARNING**            **The detachable power cord is the instrument disconnecting device. It disconnects the mains circuits from the mains supply before other parts of the instrument. The front panel switch is only a standby switch and is not a LINE switch (disconnecting device).**

---

**WARNING**            **The opening of covers or removal of parts is likely to expose dangerous voltages. Disconnect the product from all voltage sources before starting to open.**

---

**WARNING**            **These servicing instructions are for use by qualified personnel only. To avoid electrical shock, do not perform any servicing unless you are qualified to do so.**

---

---

## **Warranty**

This Agilent Technologies instrument product is warranted against defects in material and workmanship for a period of one year from date of shipment. During the warranty period, Agilent Technologies Company will, at its option, either repair or replace products which prove to be defective.

For warranty service or repair, this product must be returned to a service facility designated by Agilent Technologies. Buyer shall prepay shipping charges to Agilent Technologies and Agilent Technologies shall pay shipping charges to return the product to Buyer. However, Buyer shall pay all shipping charges, duties, and taxes for products returned to Agilent Technologies from another country.

Agilent Technologies warrants that its software and firmware designated by Agilent Technologies for use with an instrument will execute its programming instructions when properly installed on that instrument. Agilent Technologies does not warrant that the operation of the instrument, or software, or firmware will be uninterrupted or error-free.

---

## **LIMITATION OF WARRANTY**

The foregoing warranty shall not apply to defects resulting from improper or inadequate maintenance by Buyer, Buyer-supplied software or interfacing, unauthorized modification or misuse, operation outside of the environmental specifications for the product, or improper site preparation or maintenance.

NO OTHER WARRANTY IS EXPRESSED OR IMPLIED. AGILENT TECHNOLOGIES SPECIFICALLY DISCLAIMS THE IMPLIED WARRANTIES OF MERCHANTABILITY AND FITNESS FOR A PARTICULAR PURPOSE.

---

## **EXCLUSIVE REMEDIES**

THE REMEDIES PROVIDED HEREIN ARE BUYER'S SOLE AND EXCLUSIVE REMEDIES. AGILENT TECHNOLOGIES SHALL NOT BE LIABLE FOR ANY DIRECT, INDIRECT, SPECIAL, INCIDENTAL, OR CONSEQUENTIAL DAMAGES, WHETHER BASED ON CONTRACT, TORT, OR ANY OTHER LEGAL THEORY.

<b>1. Overview</b>	
What You Will Find in This Chapter . . . . .	14
Agilent PSA Series Spectrum Analyzer Overview . . . . .	15
Instrument Hardware Option Descriptions . . . . .	16
Before Troubleshooting a Failure . . . . .	19
ESD Information . . . . .	19
Service Equipment You Will Need . . . . .	22
Service Kit Parts List . . . . .	22
Required Test Equipment List . . . . .	24
Replacement Assemblies . . . . .	34
Battery Information . . . . .	36
After an Instrument Repair . . . . .	36
Contacting Agilent Technologies . . . . .	37
Instrument Serial Numbers . . . . .	39
How to Return Your Instrument for Service . . . . .	40
<b>2. Overall Troubleshooting</b>	
What You Will Find in This Chapter . . . . .	44
Check the Basics . . . . .	45
Troubleshooting Power-up Problems . . . . .	46
Troubleshooting an Inoperative Instrument . . . . .	47
Check the Instrument Setup . . . . .	47
Initial Checks . . . . .	47
Troubleshooting Using Auto-Align Tests . . . . .	49
Quick Cals . . . . .	52
Isolating the faulty assembly when the displayed amplitude is incorrect or the instrument fails a gain related Auto Align test . . . . .	53
Troubleshooting Using Front Panel Keys . . . . .	57
Error Messages . . . . .	57
Using Service Features . . . . .	58
Using Alignment Features . . . . .	62
Selecting the Frequency Reference . . . . .	64
User Diagnostics . . . . .	64
Restore System Defaults . . . . .	64
Troubleshooting Performance Test Failures . . . . .	65
<b>3. Troubleshooting the RF Section (E4440A, E4443A, E4445A)</b>	
What You Will Find in This Chapter . . . . .	70
RF Section Description (E4440A, E4443A, E4445A) . . . . .	71
RF Assembly Quick Check - E4440A, E4443A, E4445A . . . . .	75
Verifying a Faulty Front End Assembly E4440A, E4443A, E4445A . . . . .	75
<b>4. Troubleshooting the RF Section (E4446A, E4447A, E4448A)</b>	
What You Will Find in This Chapter . . . . .	90

---

# Contents

RF Section Description (E4446A, E4447A, E4448A) .....	91
RF Assembly Quick Check - E4446A, E4447A, E4448A .....	95
Verifying a Faulty Front End Assembly E4446A, E4447A, E4448A .....	95
<b>5. Troubleshooting the Synthesizer Section</b>	
What You Will Find in This Chapter .....	112
A12 Synthesizer Assembly Description .....	113
Verifying the A12 Synthesizer Board .....	114
Troubleshooting LO and Sampling Oscillator Unlock Conditions: .....	114
E4440-60049 Extender Board .....	116
A11 Reference Assembly Description .....	118
100 MHz VCXO .....	119
300 MHz Outputs .....	119
600 MHz Outputs .....	119
Reference Unlock Detector .....	119
50 MHz Calibrator Output .....	119
10 MHz Outputs .....	119
Interconnections to other assemblies .....	119
Verifying the A11 Reference Board .....	120
Reference Assembly Quick Check .....	120
Reference Assembly Detailed Troubleshooting .....	121
A9 Second LO/Fan Control Assembly Description .....	122
Second LO Circuitry .....	122
Fan Control Circuitry .....	122
Verifying the A9 2nd LO/ Fan Control Board .....	123
If the Fans Are Not Operating .....	123
<b>6. Troubleshooting the IF Section</b>	
What You Will Find in This Chapter .....	126
A10 Third Converter Assembly Description .....	127
Step Attenuator .....	127
System Variable Gain Compensation Circuitry .....	127
Linearization Circuit .....	127
50 MHz Calibrator ALC .....	127
321.4 MHz Filter .....	127
321.4 MHz Cal Signal Mixer .....	128
3rd Mixer .....	128
Interconnections to other assemblies .....	128
Verifying the A10 Third Converter Board E4440A, E4443A, E4445A, E4446A, E4448A) .....	129
Third Converter Troubleshooting .....	129
Verifying the A10 Third Converter Board (E4447A) .....	131
Third Converter Troubleshooting .....	131
A8 Analog IF Assembly Description .....	133

---

# Contents

Pre-filters . . . . .	133
Main Gain Amplifier . . . . .	133
21.4 MHz Anti-Alias Filter . . . . .	134
Mixer . . . . .	134
Fourth L.O. . . . .	134
Post Down Conversion Filtering . . . . .	134
Calibration Generator . . . . .	134
Clock Generator . . . . .	134
Triggering . . . . .	135
Power Supply Switching Reference . . . . .	135
Interconnections to other assemblies . . . . .	135
Verifying the A8 Analog IF Assembly Signal Path . . . . .	136
Analog IF Assembly Quick Check . . . . .	136
Analog IF Assembly Detailed Troubleshooting . . . . .	137
A7 Digital IF Assembly Descriptions . . . . .	139
7.5 MHz IF . . . . .	139
Gain Range Select/Rules . . . . .	139
Offset Adjust and Dither . . . . .	139
Interconnections to other assemblies . . . . .	140
Verifying the A7 Digital IF Board . . . . .	141
Digital IF Assembly Quick Check . . . . .	141
Digital IF Assembly Detailed Troubleshooting . . . . .	142
<b>7. Troubleshooting the Processor, Power Supply, and Display</b>	
What You Will Find in This Chapter . . . . .	146
A25 Motherboard Description . . . . .	147
A26 CPU Assembly Description . . . . .	148
Verifying the A26 CPU Assembly . . . . .	149
CPU Assembly Quick Check . . . . .	149
CPU Assembly Detailed Troubleshooting . . . . .	152
Battery Information . . . . .	152
A5 Power Supply Assembly Description . . . . .	153
Isolating an A5 Power Supply Problem . . . . .	154
Verifying the Individual Voltage Supplies . . . . .	155
A6 SCSI Interface Board Description . . . . .	158
Front Frame Description . . . . .	159
A1 LCD Display . . . . .	159
A3 Keyboard . . . . .	159
A2 Front Panel Interface Assembly . . . . .	159
A23 Disk Drive . . . . .	159
Isolating a Display Problem . . . . .	160
Verifying the Inverter Boards . . . . .	160
Verifying HSYNC, VSYNC, and LCD Clock . . . . .	162
Rear Panel Description . . . . .	164
<b>8. Hardware Options</b>	
What You Will Find in This Chapter . . . . .	166
Verifying Option 107 Audio Input . . . . .	167

---

# Contents

Verification of Option 107 .....	168
Verifying Option 110 .....	169
Verification of Option 110 .....	169
Overview of Option 115 Extended Memory (all PSA Series) .....	172
Verification of Option 115 .....	173
Verifying Option 122 or 140, Wide Bandwidth Digitizer .....	174
Setting up the instrument in wideband mode: .....	175
Setting up the instrument in narrow band mode: .....	176
If the problem only exists in the wideband path: .....	177
Viewing the wide band response to a comb signal (inner loop test): .....	178
Viewing the wide band response to a comb signal (outer loop test): .....	179
Wide Band Analog IF Assembly Filter Path Test .....	181
Option 122 or 140 Lowband Filters .....	183
Overview and Verification of Option 123, Microwave and Millimeter Preselector Bypass .....	187
Overview of Option 123 in the E4440A, E4443A, or E4445A .....	187
Overview of Option 123 in the E4446A, E4447A, or E4448A .....	197
Verifying Option 124, Y-Axis Video Out .....	203
Procedure 1 - Quick check of video out level .....	203
Procedure 2 - Detailed view of the video signal .....	204
<b>9. Block Diagrams</b>	
What You Will Find in This Chapter .....	208
Signal Mnemonics .....	209
Overall Block Diagrams .....	212
<b>10. Replaceable Parts Lists and Locations</b>	
What You Will Find in This Chapter .....	222
Replaceable Parts .....	224
Hardware .....	249
<b>11. Assembly Replacement Procedures</b>	
What You Will Find in This Chapter .....	306
Before Starting .....	307
Safety .....	307
Tools you will need .....	308
Adjustments after an instrument repair .....	308
Major Assembly Locations .....	309
Instrument Outer Case .....	310
Removal .....	310
Replacement .....	311
Top Brace .....	312
Removal .....	312
Replacement .....	313
Front Frame .....	314
Drop the Front Frame .....	314



---

# Contents

Removal . . . . .	315
Replacement . . . . .	316
RF Section	
E4440A, E4443A, E4445A . . . . .	317
Complete RF Section. . . . .	317
RF Assemblies	
E4440A, E4443A, E4445A . . . . .	320
A18 YTO and A19 RYTHM. . . . .	322
A21 SLODA . . . . .	323
FL1 Low Pass Filter . . . . .	323
FL2 Band Pass Filter . . . . .	324
A20 Lowband. . . . .	324
RF Section Option Assemblies	
E4440A, E4443A, E4445A . . . . .	325
A22 Preamplifier. . . . .	326
A27 Electronic Attenuator . . . . .	326
Option 110 Assemblies (E4440A, E4443A, E4445A) . . . . .	327
Option 123 Assemblies . . . . .	330
RF Section	
E4446A, E4447A, E4448A . . . . .	336
Complete RF Section. . . . .	336
RF Assemblies	
E4446A, E4447A, E4448A . . . . .	339
A18 YTO and A19 SBTX/RYTHM . . . . .	341
A21 FELOMA . . . . .	342
FL1 Low Pass Filter . . . . .	342
FL2 Band Pass Filter . . . . .	343
A20 Lowband (E4446A, E4448A). . . . .	343
A20 Lowband (E4447A only) . . . . .	344
A29 SBTX Driver Board . . . . .	345
A30 FIFA . . . . .	345
RF Section Option Assemblies	
E4446A, E4447A, E4448A . . . . .	346
A22 Preamplifier. . . . .	347
A27 Electronic Attenuator . . . . .	347
Option 110 Assemblies	
E4446A, E4447A, E4448A . . . . .	348
Option 123 Assemblies	
E4446A, E4447A, E4448A . . . . .	352
Attenuator Assembly	
E4440A, E4443A, E4445A . . . . .	357
Removal . . . . .	357
Replacement . . . . .	358
Attenuator Assembly	
E4446A, E4447A, E4448A . . . . .	359
Removal . . . . .	359
Replacement . . . . .	360
A5 Power Supply . . . . .	361

---

# Contents

Removal	361
Replacement	362
A39 USB/Memory Board	363
Removal	363
Replacement	365
A6 SCSI Board	366
Removal	366
Replacement	366
Vertical Board Assemblies (Standard Instrument)	367
Removal	371
A10 Third Converter Removal Procedure (E4447A only)	372
Replacement	372
Fans/Mid Web	374
Fans	374
Mid Web	376
A23 Disk Drive	378
Removal	378
Replacement	381
A25 Motherboard	382
Removal	382
Replacement	384
A26 CPU Assembly	385
Removal	385
Replacement	387
Battery Replacement	387
A26A1 DRAM and A26A2 Flash Boards	388
Removal	388
Replacement	389
Rear Frame	390
Removal	390
Replacement	392
RF Input Connector	393
Removal	393
Replacement	394
Front Frame Subassemblies	395
Front Frame Exploded View	397
A1 Display and Filter	398
A2 Front Panel Interface Board	402
Bezel and Keypad	404
RPG	407
External Trigger Cable	407
<b>12. Post-Repair Procedures</b>	
What You Will Find in This Chapter	410
Before Starting	411
Test equipment you will need	411
Post-Repair Procedures	412

Burst Trigger Check . . . . .	419
Internal Front Panel Test . . . . .	420
28 V Rear Panel Output Check . . . . .	421
Configuring a Replacement CPU Assembly . . . . .	422
Description . . . . .	422
Procedure . . . . .	422
Configuring a Replacement Flash Memory Assembly . . . . .	425
Description . . . . .	425
Equipment Required . . . . .	425
Procedure . . . . .	426
<b>13. Firmware Upgrades</b>	
Firmware Upgrades Including Measurement Personality Upgrades . . . . .	430



---

# **1 Overview**

## What You Will Find in This Chapter

This chapter provides overview information on your spectrum analyzer.

The following sections are found in this chapter:

- PSA Overview.....page 15
- Hardware Option Descriptions .....page 15
- Before Troubleshooting a Failure.....page 19
- Service Equipment You Will Need .....page 22
- Contacting Agilent Technologies .....page 37

## **Agilent PSA Series Spectrum Analyzer Overview**

The Agilent PSA Series Performance Spectrum Analyzers measure and monitor complex RF and microwave signals. The analyzers integrate traditional spectrum measurements with advanced vector signal analysis, optimizing speed, accuracy, and dynamic range.

The Agilent PSA Series spectrum analyzers are readily adaptable to meet changing measurement needs. Optional features enable the analyzer to be configured as a comprehensive analytical tool for communications systems and components. Refer to the Getting Started Guide for your analyzer for more information about options.

## Instrument Hardware Option Descriptions

The following list documents hardware options that are orderable on new instruments. Hardware upgrade option numbers for field installable retrofits kits may not be covered in this list.

**Option AYZ (E4440A, E4446A, E4447A, E4448A)** Adds external mixing capability in the form of front panel LO Out and IF Input connectors. Option AYZ supports both preselected and unpreselected harmonic mixers. The front panel LO Out cable is connected to a spare port on the instrument's LO distribution amp. Other options that also require connections to the LO distribution amp will be incompatible with Option AYZ.

**Option BAB (E4440A)** Replaces the front panel Type-N input connector with a 3.5 mm male connector.

**Option B7J (All PSA Series)** Adds an electronic attenuator to the lowband path (< 3.05 GHz). Sometimes this option is referred to as the "digital demod hardware" since the attenuator is required for the optional digital communications applications.

**Option 1DS (All PSA Series)** Adds a 100 kHz to 3.05 GHz Preamp to the lowband path.

**Option 107 (All PSA Series)** Audio Input (for use with Option 223, Measuring Receiver Personality only). Option 107 consists of an Audio board and a front panel BNC connector. The audio signal path is in addition to, and completely bypasses the normal RF/IF signal chain. The frequency range is 20 Hz to 250 kHz. Usable amplitude range is 0.1 Vrms to 3 Vrms.

The audio signal comes from the front panel BNC connector, goes to the Audio board where the signal is buffered, level shifted (ADC ranging circuit provided best signal to ADC), then run through an ADC followed by an FPGA that provides filtering and decimation to the ADC bits. The time domain FPGA bits are sent to the PSA CPU assembly via the PCI bus.

**Option 110 (All PSA Series)** 10 MHz to 26.5 or 50 GHz preamplifier. Provides approximately 30 dB of gain from 10 MHz to the upper frequency range of the analyzer. The preamplifier can be switched in or out of the signal path. Option 110 and Option 1DS cannot be installed together.

**Option 111 (All PSA Series)** USB Device side I/O. Allows a link for controlling the instrument and extracting data from it through a standard SCPI programming interface. This feature does not provide USB host side support. It will not enable control of USB mass storage devices or printers. In its simplest form, it can be thought of as a faster



version of GPIB. Requires USB/Memory board assembly. USB/Memory board contains both USB and extended memory circuitry although a license keyword is required for each option.

**Option 115 (All PSA Series) Extended Memory.** Provides 512 MB of additional memory for optional measurement personality or user files such as state or trace files. Requires USB/Memory board assembly. USB/Memory board contains both USB and extended memory circuitry although a license keyword is required for each option. See Option 117 Secure Memory description for additional information.

**Option 117 (All PSA Series) Secure Memory Erase.** Forces all user files such as trace, state and screen data to be stored only on the extended memory board. Prohibits the storage of instrument measurement personalities or any other non-user data.

Two levels of security are provided. Provides a means to thoroughly erase only user data by erasing the contents of the extended memory board. This level of security allows the core analyzer and measurement personalities to remain intact so the analyzer will still function.

The second level is an erase all routine that clears all instrument memory including memory on the CPU assembly resulting in a non-functional instrument.

See “Managing Security” under the Systems section of the PSA User's Guide (Volume 1) and the firmware upgrade chapter in this manual for important information.

Requires USB/Memory board assembly and license keyword for Option 117. Option 115 is incompatible with Option 117 since Option 115 also provides storage of measurement personalities to the extended memory board.

**Option 122 (E4440A, E4443A, E4445A, E4446A, E4448A)**  
80 MHz Bandwidth Digitizer. Provides 80 MHz wideband IF from 10 MHz to the upper frequency range of the analyzer. This option adds the A31 Wideband Analog IF and A32 Wideband Digital IF assemblies and associated filtering and cabling.

**Option 123 (All PSA Series) Switchable Microwave and Millimeter Wave Preselector Bypass.** Provides a switchable signal path that bypasses both the microwave 3 to 26.5 GHz preselector in RHYTHM, and the 26.5 to 50 GHz preselector in the SBTX. The option adds a microwave mixer and switches. If this option is installed, Option AYZ external mixing cannot be installed due to limited LO ports.

**Option 124 (All PSA Series)** Adds a 0 to 1 V Video output on the rear panel. This video out has run through the normal IF paths and is envelope detected after it has been conditioned by the resolution bandwidth, video bandwidth reference level and scale settings. The video out is always active even when the instrument is in zero span and not being swept. Updating early instruments requires changing the A7 Digital IF assembly.

**Option 140 (E4440A, E4443A, E4445A, E4446A, E4448A)**  
40 MHz Bandwidth Digitizer. Provides 40 MHz wideband IF from 10 MHz to the upper frequency range of the analyzer. This option adds the A31 Wideband Analog IF and A32 Wideband Digital IF assemblies and associated filtering and cabling.

## Before Troubleshooting a Failure

Before troubleshooting, complete the following three tasks:

1. Familiarize yourself with the safety symbols marked on the instrument and read the safety information provided on [page 2](#) of this guide.
2. Read the ESD Information below.
3. Familiarize yourself with the troubleshooting information in the Overall Troubleshooting chapter, and how it relates to information on troubleshooting the RF, IF, Synthesizer, and Controller in this guide.

### ESD Information

#### Protection from Electrostatic Discharge

Electrostatic discharge (ESD) can damage or destroy electronic components. All work on electronic assemblies should be performed at a static-safe workstation. [Figure 1-1](#) shows an example of a static-safe workstation using two types of ESD protection:

- Conductive table-mat and wrist-strap combination.
- Conductive floor-mat and heel-strap combination.

Both types (when used together) provide a significant level of ESD protection. Only the table-mat and wrist-strap combination provide adequate ESD protection when used alone. To ensure user safety, the static-safe accessories must provide at least 1 M $\Omega$  of isolation from ground. Refer to [Table 1-1](#) for information on ordering static-safe accessories.

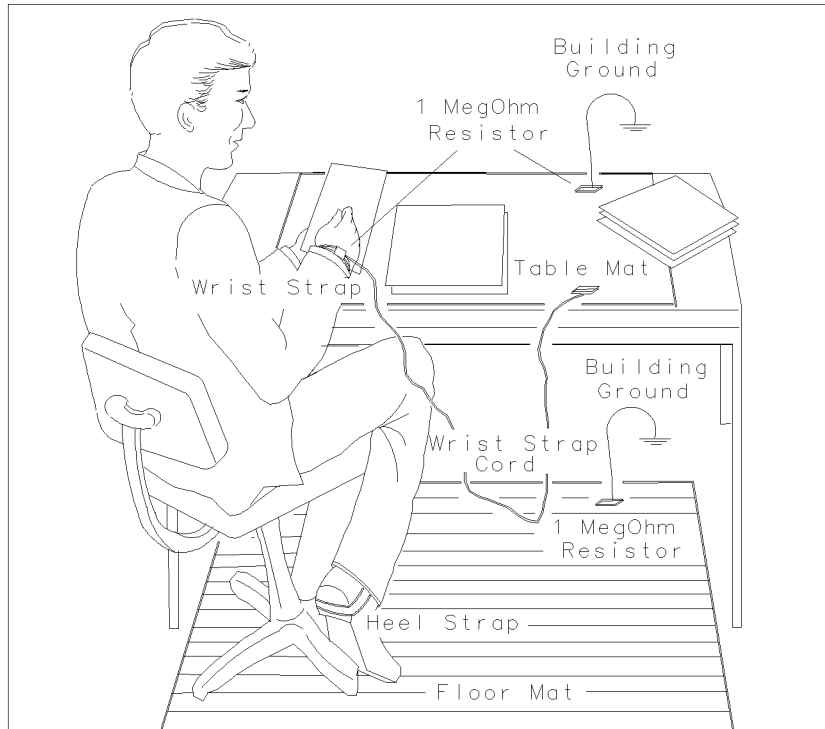
---

**WARNING**

**These techniques for a static-safe workstation should not be used when working on circuitry with a voltage potential greater than 500 volts.**

---

**Figure 1-1 Example of a Static-Safe Workstation**



FORMAT46

**Table 1-1 Static Safe Accessories**

Agilent Part Number	Description
9300-0797	Set includes: 3M static control mat 0.6 m × 1.2 m (2 ft. × 4 ft.) and 4.6 cm (15 ft.) ground wire. (The wrist-strap and wrist-strap cord are not included. They must be ordered separately.)
9300-0980	Wrist-strap cord 1.5 m (5 ft.)
9300-1367	Wrist-strap, color black, stainless steel, without cord, has four adjustable links and a 7 mm post-type connection.
9300-1308	ESD heel-strap (reusable 6 to 12 months)

## Handling Electronic Components and ESD

The possibility of unseen damage caused by ESD is present whenever components are transported, stored, or used. The risk of ESD damage can be greatly reduced by close attention to how all components are handled. Refer to the following guidelines when handling components:

- Perform work on all components at a static-safe workstation.
- Keep static-generating materials at least one meter away from all components.
- Store or transport components in static-shielding containers.

---

**CAUTION**

Always handle printed circuit board assemblies by the edges. This will reduce the possibility of ESD damage to components and prevent contamination of exposed plating.

---

## Test Equipment Usage and ESD

- Before connecting any coaxial cable to an instrument connector for the first time each day, momentarily short the center and outer conductors of the cable together.
- Personnel should be grounded with a 1 M $\Omega$  resistor-isolated wrist-strap before touching the center pin of any connector and before removing any assembly from the instrument.
- Be sure that all instruments are properly earth-grounded to prevent build-up of static charge.

## Additional Information about ESD

For more information about preventing ESD damage, contact the Electrical Over Stress/Electrostatic Discharge (EOS/ESD) Association, Inc. The ESD standards developed by this agency are sanctioned by the American National Standards Institute (ANSI).

## Service Equipment You Will Need

The service kit facilitates making measurements on various assemblies within the instrument. Refer to [Table 1-3](#) for a list of recommended Agilent test equipment used for making measurements. Alternative equipment model numbers are given in case the recommended equipment is not available.

**NOTE** If neither the recommended nor the alternative test equipment are available, you may use substitute equipment that meets or exceeds the critical specifications required to perform measurements.

### Service Kit Parts List

The service kit contains extender boards that enable access to measurement points that cannot otherwise be accessed when the instrument is operational.

**Table 1-2 Agilent Service Kit (Agilent part number E4440-60090)**

Agilent Part	Agilent Part Number	Specifications
<b>Extender Boards</b>		
A7 DIF Extender Board	E4406-60021	
A8 AIF, A9 2 <sup>nd</sup> LO Extender Board	E4440-60048	
A10, A11, A12, A13 Extender Board	E4440-60049	
A13J12 Bias Adjustment Board	E4440-60041	
Synthesizer Extender Board Guides (2 ea.)	E4440-00025	
Synthesizer Board Support (2 ea.)	E4440-00026	
Synthesizer Board Support (2 ea.)	E4440-20113	
<b>Cables</b>		
20-Conductor Ribbon Cable (3 ea.)	E4440-60331	Specific to preamp, electronic attenuator, FIFA.
10-Conductor Ribbon Cable	E4440-60332	Specific to SLODA.
8-Conductor Ribbon Cable	E4440-60333	Specific to YTO.

**Table 1-2 Agilent Service Kit (Agilent part number E4440-60090)**

<b>Agilent Part</b>	<b>Agilent Part Number</b>	<b>Specifications</b>
10-Conductor Ribbon Cable (3 ea.)	E4440-60071	To extend front end driver board (Atten A, Atten B, YTO).
26-Conductor Ribbon Cable	E4440-60072	To extend front end driver board (Lowband).
14-Conductor Ribbon Cable	E4440-60337	To extend front end driver board (RYTHM).
SMA Cable (Flexible)	5062-2662	To extend 2 <sup>nd</sup> LO and Sampler LO semi-rigid cables when boards are on extender boards.
SMB Gray Cable (2 ea.)	8120-5020	To extend SMB cables.
MMCX Cable	8120-8866	To measure output jacks on the A12 synthesizer assembly.
<b>Miscellaneous Items</b>		
SMA “Barrel”	1250-1158	To extend semi-rigid cables
SMB “Barrel” (2 ea.)	1250-0669	To extend SMBs
SMB Cable Puller	5021-6773	

## Required Test Equipment List

The following table identifies the equipment recommended for troubleshooting, adjusting, and verifying the performance of the instrument. Only the recommended and alternate equipment is compatible with the performance verification testing. Some tests can use various models of a particular equipment type. The “Recommended Agilent Model” is the preferred equipment. However, the “Alternative Agilent Model” is an acceptable substitute.

**Table 1-3 Required Test Equipment for PSA Series**

Instrument	Critical Specifications	Recommended Agilent Model Number	Alternative Agilent Model Number	Use <sup>a</sup>
<b>Signal Sources</b>				
RF Source 1 (for Option B7J) Not required for Agilent Recommended test plan variant)	Ability to create 64 tones across a 5 MHz span synchronously, 5 MHz to 10 MHz Resolution: 0.02	E4433B (Option UND)	E4437B (Option UND FW datecode ≥ B.02.24)	P
RF Source 2	Frequency: 50 MHz to 1.0 GHz Harmonics: < -30 dBc ≤ +13 dBm Spectral Purity SSB Phase Noise @ 1 GHz: -112 dBc at 100 Hz offset -121 dBc at 1 kHz offset -131 dBc at 10 kHz offset VSWR: < 1.5:1	E8257D <sup>b</sup>	PSG <sup>cd</sup>  8663A	A, P, T
RF Source 3	Frequency: 100 kHz to 3.0 GHz Spectral Purity: SSB Phase Noise @ 1 GHz: -145 dBc at 100 kHz offset -158 dBc at 1 MHz offset -160 dBc at 6 MHz offset -160 dBc at 10 MHz offset Harmonics: -30 dBc @ ≤ +10 dBm output	E8257D <sup>b</sup>	PSG <sup>cd</sup>  8665A/B (Option 004) (for Freq Resp below 3.6 GHz test and Phase Noise > 30 kHz test only)  8665A/B (std)	P
Microwave Source 1 (for E4440A, 43A, 45A)	Frequency: 10 MHz to 26.5 GHz Frequency Resolution: 1 Hz Harmonic level: < -30 dBc Amplitude range: -20dBm to +13 Amplitude resolution: 0.02 VSWR: < 20 GHz: 1.6:1 ≤ 31 GHz: 1.8:1	E8257D <sup>b</sup>	83630A/B 83640A/B 83650A/B (Option 001, 008) (One sweeper requires Option 001 for PSA Option 110 testing)  PSG <sup>cd</sup>	A, P, T



**Table 1-3 Required Test Equipment for PSA Series (Continued)**

Instrument	Critical Specifications	Recommended Agilent Model Number	Alternative Agilent Model Number	Use <sup>a</sup>
Microwave Source 1 (for E4446A, 47A, 48A)	Frequency: 10 MHz to 50 GHz Frequency Resolution: 1 Hz Harmonic level: < -30 dBc Amplitude range: -20dBm to +13 Amplitude resolution: 0.02 VSWR: < 20 GHz: 1.6:1 ≤ 40 GHz: 1.8:1 ≤ 50 GHz: 2.0:1	E8257D <sup>b</sup>	83650A/B (Option 001, 008)  PSG <sup>cd</sup>	A, P, T
Microwave Source 2 (only required for Third Order Intermodulation and Gain Compression)	Frequency: 10 MHz to 26.5 GHz Frequency Resolution: 1 Hz Harmonic level: < -30 dBc Amplitude range: -20dBm to +13 Amplitude resolution: 0.02 VSWR: < 20 GHz: 1.6:1 ≤ 31 GHz: 1.8:1	PSG <sup>c</sup>	83630A/B 83640A/B 83650A/B (Option 001, 008) (One sweeper requires Option 001 for PSA Option 110 testing)	A, P, T
Function Generator 1	Frequency: 10 Hz to 300 kHz Amplitude Resolution: 0.1 mv Harmonic Distortion: -35 dBc	33250A	33120A 33120A (Option 001)	A, P
Audio Source 1 (for Option 107)	THD: 20 Hz to 125 kHz < -68 dB	Stanford Research DS360 Stanford Research Systems, Sunnyvale, CA		P
<b>Counters</b>				
Universal Counter	Frequency: 10 MHz Gate time: 10 to 100 seconds Must be capable of measuring signal at +7 dBm (0.5 Vrms)	53132A	53131A	P, T
<b>Meters</b>				
Digital Multimeter	AC Accuracy: ± 0.31% of reading	3458A		A, T
Power Meter	Dual Channel Absolute Accuracy: ± 0.5% Resolution: 0.01 dB Power Reference Accuracy: 1.2% (± 0.9% rss) Compatible with 8480 series power sensors dB relative mode	E4419B	E4419A  N1912A	A, P

**Table 1-3 Required Test Equipment for PSA Series (Continued)**

Instrument	Critical Specifications	Recommended Agilent Model Number	Alternative Agilent Model Number	Use <sup>a</sup>
RF Power Sensor (2 required)	Frequency Range: 100 kHz to 3 GHz Amplitude Range: -30 to +20 dBm Zero Set: $\pm 50$ nW Zero Drift: $< \pm 10$ nW Measurement Noise: $< 110$ nW Cal Factor Uncertainty (std): $< 1.6\%$ VSWR 50 MHz: $\leq 1.05$ 100 kHz to 1 MHz: $\leq 1.20:1$ 1 MHz to 2 GHz: $\leq 1.10:1$ 2 GHz to 3 GHz: $\leq 1.30:1$ Option H84 Cal Factor: Characterized by standards lab to: $\pm 0.6\%$ <sup>e</sup> Input Connector: Type-N (m)	8482A (Option H84)	8482A STD (Will increase measurement uncertainty)	A, P
Power Sensor (for Option B7J)	Frequency Range: 10 MHz to 3 GHz Amplitude Range: -30 to +20 dBm Zero Set: $\pm 50$ nW Zero Drift: $< \pm 10$ nW Measurement Noise: $< 110$ nW Cal Factor Uncertainty (std): $< 1.6\%$ VSWR: 50 MHz: $\leq 1.10:1$ 50 MHz to 3 GHz: $\leq 1.18:1$ Option H84 Cal Factor: Characterized by standards lab to: $\pm 0.6\%$ <sup>e</sup> Input Connector: Type-N (m)	8481A (Option H84)	8481A, STD (Will increase measurement uncertainty)	P
Microwave Power Sensor (for E4440A, E4443A, E4445A)	Frequency Range: 50 MHz to 26.5 GHz Amplitude Range: -30 to +20 dB Zero Set: $\pm 50$ nW Zero Drift: $< \pm 10$ nW Measurement Noise: $< 110$ nW Cal Factor Uncertainty (std): $< 2.3\%$ VSWR: 50 MHz to 100 MHz: 1.15:1 100 MHz to 2 GHz: 1.10:1 2 GHz to 12.4 GHz: 1.15:1 12.4 GHz to 18 GHz: 1.20:1 18 GHz to 26.5 GHz: 1.25:1 Input Connector: 3.5 mm (m)	8485A	8487A	A, P
Millimeter Power Sensor (for E4446A, E4447A, E4448A)	Frequency Range: 50 MHz to 50 GHz Amplitude Range: -30 to +20 dBm Zero Set: $\pm 50$ nW Zero Drift: $< \pm 10$ nW Measurement Noise: $< 110$ nW Cal Factor Uncertainty (std): $< 4.5\%$ VSWR: 50 MHz to 100 MHz: 1.15:1 100 MHz to 2 GHz: 1.10:1 2 GHz to 12.4 GHz: 1.15:1 12.4 GHz to 18 GHz: 1.20:1 18 GHz to 26.5 GHz: 1.25:1 26.5 GHz to 40 GHz: 1.30:1 40 GHz to 50 GHz: 1.50:1 Input Connector: 2.4 mm coaxial (m)	8487A		A, P

**Table 1-3 Required Test Equipment for PSA Series (Continued)**

Instrument	Critical Specifications	Recommended Agilent Model Number	Alternative Agilent Model Number	Use <sup>a</sup>
High Sensitivity Microwave Power Sensor <i>(for Option 110 on E4440A, 43A, 45A)</i>	Frequency Range: 50 MHz to 26.5 GHz Amplitude Range: -70 to -20 dB Zero Set: $\pm 20$ pW Zero Drift: $< \pm 4$ pW Measurement Noise: $< 4$ pW Cal Factor Uncertainty (std): $< 2.6\%$ VSWR: 50 MHz to 100 MHz: 1.19:1 100 MHz to 4 GHz: 1.15:1 4 GHz to 12 GHz: 1.19:1 12 GHz to 18 GHz: 1.25:1 18 GHz to 26.5 GHz: 1.29:1 Input Connector: 3.5 mm (m)	8485D	8487D	A, P
High Sensitivity Microwave Power Sensor <i>(for Option 110 on E4446A, 47A, 48A)</i>	Frequency Range: 50 MHz to 50 GHz Amplitude Range: -70 to -20 dB Zero Set: $\pm 20$ pW Zero Drift: $< \pm 4$ pW Measurement Noise: $< 4$ pW Cal Factor Uncertainty (std): $< 4.5\%$ VSWR: 50 MHz to 100 MHz: 1.19:1 100 MHz to 4 GHz: 1.15:1 4 GHz to 12.4 GHz: 1.20:1 12.4 GHz to 18 GHz: 1.29:1 18 GHz to 34 GHz: 1.37:1 34 GHz to 40 GHz: 1.61:1 40 GHz to 50 GHz: 1.89:1 Input Connector: 2.4 mm (m)	8487D		A, P
<b>Standards</b>				
Frequency Standard	Frequency: 10 MHz Accuracy: $< \pm 1 \text{ e}10^{-10}$	Symmetricom 5071A	Agilent 5061B, 5071A	A, P
50 MHz, -25 dBm Calibrator	Frequency Drift: $< 2.5$ kHz Typical VSWR: 1.06:1 Output Power Variation: $\pm 0.004$ dB Total Harmonic Content: -45 dBc	Z5602A Opt H51 for Type N Opt H35 for BAB Opt H24 for E4446A, E4448A		A
<b>Attenuators</b>				
10 dB Step Attenuator	Range: 0 to 110 dB Accuracy: Characterized by standards lab to: $\pm 0.005 + 0.005/10 \text{ dB step}^f$ Calibrated at 50 MHz VSWR: at 50 MHz: $\leq 1.05:1$	8496G	8496H	P
1 dB Step Attenuator	Range: 0 to 11 dB Accuracy: Characterized by standards lab to: $\pm 0.005 \text{ dB}^f$ Calibrated at 50 MHz VSWR: at 50 MHz: $\leq 1.05:1$	8494G	8494H	P
Attenuator Interconnect Kit	Type N connector kit to connect 8496G to 8494G	11716A		P

**Table 1-3 Required Test Equipment for PSA Series (Continued)**

Instrument	Critical Specifications	Recommended Agilent Model Number	Alternative Agilent Model Number	Use <sup>a</sup>
Attenuator Driver	Compatible with the 8496G and 8494G step attenuators.	11713B	11713A	P
3 dB Fixed Attenuator	3 dB Type-N (m, f) Frequency: 50 MHz VSWR: at 50 MHz: $\leq 1.05:1$	8491A (Option 003)	8491B/C (Option 003)	P
6 dB Fixed Attenuator	6 dB Type-N (m, f) VSWR: at 50 MHz: $\leq 1.05:1$	8491A (Option 006)	8491B/C (Option 006)	P
10 dB Fixed Attenuator	10 dB Type N (m, f) Frequency: 50 MHz VSWR: at 50 MHz: $\leq 1.05:1$	8491A (Option 010)	8491B/C (Option 010)	P
10 dB Fixed Attenuator	10 dB 3.5 mm (m, f) VSWR: 321.4 MHz to 19.5 GHz: $\leq 1.1:1$	8493C (Option 010)		A, P
20 dB Fixed Attenuator	20 dB Type-N (m, f) Accuracy: $\pm 0.5$ dB VSWR: 100 kHz to 3 GHz: $\leq 1.20:1$	8491A (Option 020)	8491B/C (Option 020)	A
20 dB Fixed Attenuator	20 dB 3.5 mm (m, f) Accuracy: $\pm 0.5$ dB VSWR: DC to 7.1 GHz: $\leq 1.20:1$	8493C (Option 020)		A, P
30 dB Fixed Attenuator	30 dB Accuracy: $\pm 0.05$ dB VSWR: 1.05 @ 50 MHz (for use with Low Power Sensors)	11708A		A, P
<b>Terminations</b>				
Type-N (m)	50 $\Omega$ Frequency: 10 kHz to 18 GHz VSWR: 4 GHz: $\leq 1.05:1$	909A (Option 012)		P, T
3.5 mm (f)	50 $\Omega$ VSWR: $\leq 26.5$ GHz: $\leq 1.12:1$	909D		P
2.4 mm (f) (for E4446A, 47A, 48A)	50 $\Omega$ Frequency: 10 kHz to 50 GHz	85138B		P
BNC (m)	50 $\Omega$ Frequency: 10 kHz to 50 GHz	1250-0207		P
<b>Miscellaneous Devices</b>				
RF Power Splitter	Frequency: 9 kHz to 3 GHz VSWR: $\leq 1.10:1$ Connector: Type-N (f)	11667A		P
Microwave Power Splitter (for E4440A, 43A, 45A)	Frequency: 10 MHz to 26.5 GHz VSWR: 10 MHz to 3 GHz: $< 1.06:1$ 3 GHz to 26.5 GHz: $< 1.22:1$ Tracking Error: $< \pm 0.25$ dB Connector: 3.5 mm (f)	11667B (Option H30)	11667B (std.)	P

**Table 1-3 Required Test Equipment for PSA Series (Continued)**

Instrument	Critical Specifications	Recommended Agilent Model Number	Alternative Agilent Model Number	Use <sup>a</sup>
Millimeter Power Splitter (for E4446A, 47A, 48A)	Frequency: 10 MHz to 50 GHz VSWR: ≤ 10 MHz to 18 GHz: < 1.29:1 18 GHz to 26.5 GHz: < 1.20:1 26.5 to 40 GHz: < 1.50:1 40 GHz to 50 GHz: < 1.65:1 Tracking Error: < ± 0.40 dB Connector: 2.4 mm (f)	11667C		P
Directional Bridge	Frequency Range: 5 MHz to 3 GHz Directivity: ≤ 5 MHz: 30 dB 5 MHz to 2 GHz: 40 dB 2 GHz to 3 GHz: 30 dB VSWR: ≤ 2 GHz: ≤ 1.15:1 ≤ 3 GHz: ≤ 1.22:1 Insertion Loss: ≤ 1.5, +0.1 dB/GHz Coupling (nominal): 16 dB Connector: Type N (f)	86205A		P
Directional Coupler	2 GHz to 20 GHz Directivity > 16 dB Transmission arm loss: < 1.5 dB (nominal) Coupled Arm Loss: ~10 dB (nominal) VSWR: ≤ 1.35:1 Connector: SMA (f)	87300B		P
DC Probe		11002A	11003A	A
High Frequency Probe	Frequency Range: 300 kHz to 3 GHz Input Resistance: 1 M Ω (nominal)	85024A		T
Negative Detector	50 MHz to 26.5 GHz ± 0.6 dB to 18 GHz	33330C		A
Bias Adjustment Board		E4440-60041		A
<b>Cables</b>				
3.5 mm (m) to 3.5 mm (m) (2 required)	Frequency: DC to 26.5 GHz Length: ≤ 92 cm (36 in) Insertion Loss: ~2 dB VSWR: DC to 18 GHz: ≤ 1.25:1 18 GHz to 26.5 GHz: ≤ 1.35:1	8120-4921		A, P
2.4 mm (f) to 2.4 mm (m) (for E4446A, 47A, 48A)	Frequency: DC to 50 GHz Length: ≤ 24.9 cm (9.8 in) Insertion Loss: ≤ 26 GHz, ~4 dB Insertion Loss: ≤ 40 GHz, ~5 dB Insertion Loss: ≤ 50 GHz, ~6 dB VSWR: ≤ 26.5 GHz: ≤ 1.30:1 ≤ 40 GHz: ≤ 1.40:1 ≤ 50 GHz: ≤ 1.55:1	8120-6164		A, P
Type-N (2 required)	Frequency: 10 MHz to 8 GHz Precision Type-N (m), both ends 62 cm (24 in.) VSWR: ≤ 18 GHz: 1.4:1 Insertion Loss: 1.5 dB	11500C		A, P, T

**Table 1-3 Required Test Equipment for PSA Series (Continued)**

Instrument	Critical Specifications	Recommended Agilent Model Number	Alternative Agilent Model Number	Use <sup>a</sup>
BNC (3 required)	Frequency: DC to 10 MHz 50 Ω Coax BNC (m), both ends 120 cm (48 in.)	10503A		A, P, T
<b>Filters</b>				
50 MHz Low Pass	Cutoff Frequency: 50 MHz Rejection at 65 MHz: > 40 dB Rejection at 75 MHz: > 60 dB Insertion Loss: ~1 dB VSWR: ≤ 1.5:1 BNC (m) to BNC (f)	0955-0306	Telonic Berkeley TLA 50-5AB2	P, T
300 MHz Low Pass (2 Required)	Cutoff Frequency: 300 MHz Rejection at > 435 MHz: > 45 dB VSWR: ≤ 1.5:1 BNC (m, f)	0955-0455	Telonic Berkeley TLP 300-4AB4	P
1.8 GHz Low Pass (2 Required)	Cutoff frequency: 1.8 GHz Rejection at > 3 GHz: > 45 dB Insertion Loss: ~0.25 dB VSWR: ≤ 1.35:1 SMA (f)	0955-0491	RLC Electronics L-1636	P
4.4 GHz Low Pass (2 Required)	Cutoff frequency: 4.4 GHz Rejection at > 5.5 GHz: > 42 dB	9135-0005	K + L Microwave ML253-4499/ XU-N/NP	P
1 GHz Low Pass	Center frequency: 1 GHz Rejection at 2 GHz: > 60 dB	0955-0487	RLC Electronics L-1621	P
1.0001 GHz Notch	Center frequency: 1 GHz BW: 6 MHz Rejection at 13 MHz from CF: > 50 dB		Trilithic CFN-2-1000.1	P
1 GHz Band Pass	Center frequency: 1 GHz BW: 6 MHz Rejection at 13 MHz from CF: > 50 dB	0955-1612	K & L Microwave 4C45-1000/X6-0/0	P
<b>Adapters</b>				
Type-N (f) to Type-N (f)	Frequency: DC to 18 GHz VSWR: 1.13:1	1250-1472		P
Type-N (m) to Type-N (m)	Frequency: DC to 18 GHz VSWR: ≤ 1.13:1	1250-1475		P
Type-N (f) to BNC (m)	Frequency: DC to 1.3 GHz VSWR: 1.13:1	1250-1477		P, T
Type-N (m) to BNC (m)	Frequency: DC to 1.3 GHz VSWR: 1.13:1	1250-1473		P, T
Type-N (m) to 3.5 mm (m)	Frequency: DC to 18 GHz VSWR: ≤ 1.08:1	1250-1743		P
Type-N (m) to BNC (f)	Frequency: DC to 1.3 GHz VSWR: ≤ 1.13:1	1250-1476		P

**Table 1-3 Required Test Equipment for PSA Series (Continued)**

Instrument	Critical Specifications	Recommended Agilent Model Number	Alternative Agilent Model Number	Use <sup>a</sup>
3.5 mm (f) to 3.5 mm (f) (2 Required)	Frequency: DC to 26.5 GHz VSWR: ≤ 1.05:1	83059B	1250-1749	P
3.5 mm (m) to 3.5 mm (m) (2 Required)	Frequency: DC to 26.5 GHz VSWR: ≤ 1.12:1	1250-1748		P
3.5 mm (f) to 3.5 mm (f)	Frequency: DC to 34 GHz VSWR: 1.15:1	1250-1749		P
2.4 mm (f) to 3.5 mm (m) (for E4446A, 47A, 48A)	Frequency: DC to 26.5 GHz VSWR: ≤ 1.05:1	11901D		A, P
3.5 mm (f) to Type-N (f)	Frequency: DC to 18 GHz VSWR: 1.08:1	1250-1745		A, P
3.5 mm (f) to 2.4 mm (f) (for E4446A, 47A, 48A)	Frequency: DC to 26.5 GHz VSWR: 1.05:1	11901B		P
BNC (m) to SMA(f)	Frequency: DC to 1.3 GHz VSWR: ≤ 1.13:1	1250-1700		P
Type-N (m) to 3.5 mm (f) (2 Required, Opt. BAB 3 Required)	Frequency: DC to 18 GHz VSWR: ≤ 1.08:1	1250-1744		P
Type-N (f) to 2.4 mm (f)	Frequency: DC to 18 GHz VSWR: ≤ 1.08:1	11903B		A, P
Type-N (m) to 2.4 mm (f) (for E4446A, 47A, 48A)	Frequency: DC to 18 GHz VSWR: 1.08:1	11903D		P
Type-N (f) to 3.5 mm (m)	Frequency: DC to 18 GHz VSWR: ≤ 1.14:1	1250-1750		A, P
BNC Tee (BNC f,m,f)		1250-0781		A, P
SMB (f) to BNC (f)	Frequency: DC to 1.3 GHz	1250-1236		A, P
BNC (f) to SMA (m)	Frequency: DC to 1.3 GHz	1250-1200		A, P
BNC (f) to Dual Banana		1251-2277		A, P
3.5 mm (f) to Type-N (m)	Shipped with the 8485 for adapting to the Power Reference. Only to be used for power sensor calibration.	08485-60005		A, P
2.4 mm (f) to Type-N (m)	Shipped with the 8487 for adapting to the Power Reference. Only to be used for power sensor calibration.	08487-60001		A, P
<b>Optional Equipment</b>				
10 MHz Distribution Amplifier (only needed when using the 10 MHz Distribution Amplifier setup)		Symmetricom 5087B	Agilent 5087A	A, P

a. A = Adjustments, P = Performance Testing, T = Troubleshooting)

b. Note: One PSG with Option 567, 1EA, 1E1, 007, and UNX or UNR can be used as the Microwave Source #1, RF Source #2, and RF Source #3.

(Option 007, Analog Ramp Sweep, required for Frequency Response Adjustments)

c. Supported PSG models:

E8244A

E8254A

E8257C Option H31 or 540

E8257D

E8267C Option H31 or 544

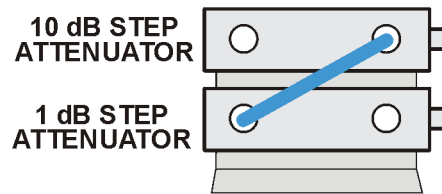
E8267D

(One sweeper requires Option 1E1 for PSA Option 110 testing)

d. PSG requires Option UNX or UNR.

e. The 8482A power sensor uses cal factors to compensate the power sensor for frequency response errors. Cal factors are stated in percentages. The 8482A factory cal factor uncertainty ranges from 2.2% to 3.1%. The cal factor uncertainty can be reduced to < 2.0% by using metrology grade calibration techniques. The power sensor cal factor uncertainty becomes one component of the Verification Test uncertainty analysis. Lower cal factor uncertainties will translate to wider test margins.

f. The step attenuators should be permanently joined via the 11716A Interconnect Kit as shown in the diagram.



step\_atten\_setup

### Step Attenuator Loss Characterization

The step attenuator combination should have each attenuator setting characterized by a metrology lab at 50 MHz. The following tables show which sections of the 10 dB and 1 dB step attenuators are utilized for each attenuator setting. The tables also list the Allowable Uncertainty for each attenuator setting. The interconnect cable should NEVER be disconnected once the loss characterization is performed.



### 1 dB Step Attenuator

Nominal Attenuation (dB)	Attenuator Section				Maximum Uncertainty (dB)
	#1 (1 dB)	#2 (2 dB)	#3 (4 dB)	#4 (4 dB)	
0	Off	Off	Off	Off	0 (Reference)
1	On	Off	Off	Off	< 0.005
2	Off	On	Off	Off	< 0.005
3	On	On	Off	Off	< 0.005
4	Off	Off	On	Off	< 0.005
5	On	Off	On	Off	< 0.005
6	Off	On	On	Off	< 0.005
7	On	On	On	Off	< 0.005
8	Off	Off	On	On	< 0.005
9	On	Off	On	On	< 0.005
10	Off	On	On	On	< 0.010
11	On	On	On	On	< 0.010

### 10 dB Step Attenuator

Nominal Attenuation (dB)	Attenuator Section				Maximum Uncertainty (dB)
	#1 (10 dB)	#2 (20 dB)	#3 (40 dB)	#4 (40 dB)	
0	Off	Off	Off	Off	0 (Reference)
10	On	Off	Off	Off	< 0.010
20	Off	On	Off	Off	< 0.015
30	On	On	Off	Off	< 0.020
40	Off	Off	On	Off	< 0.025
50	On	Off	On	Off	< 0.030
60	Off	On	On	Off	< 0.035
70	On	On	On	Off	< 0.040
80	Off	Off	On	On	< 0.046
90	On	Off	On	On	< 0.052
100	Off	On	On	On	< 0.058
110	On	On	On	On	< 0.064

## Replacement Assemblies

The instrument assemblies are not repairable to the component level. Refer to [Chapter 11](#) to determine how to disassemble and assemble the instrument. The following assemblies must be replaced as an assembly.

- A1 flat panel display
- A2 front panel interface assembly (includes inverter boards)
- A3 keyboard (does not include keypads)
- A5 power supply assembly
- A6 SCSI board
- A7 digital IF assembly
- A8 analog IF assembly
- A9 2nd LO/fan control assembly
- A10 3rd converter assembly
- A11 reference assembly
- A12 Synthesizer assembly
- A12A1 LO/synthesizer board
- A12A2 sampling oscillator board
- A13 Front end driver assembly
- A14 Input attenuator A/switch
- A15 Input attenuator B
- A18 YTO
- A19 RYTHM (models up to 26.5 GHz)
- A19 SBTX/RYTHM (43 to 50 GHz models)
- A20 Low band assembly
- A21 SLODA (models up to 26.5 GHz)
- A21 FELOMA (43 to 50 GHz models)
- A22 Preamplifier (option 1DS)
- A23 disk drive assembly
- A25 motherboard
- A26 CPU (processor) assembly (does not include A26A1 or A26A2)
- A26A1 DRAM card
- A26A2 Flash memory board

- A27 Electronic Attenuator (option B7J)
- A29 SBTX/FELOMA Driver Board (43 to 50 GHz models)
- A30 FIFA (43 to 50 GHz models)
- A31 Wideband Analog IF assembly (Option 122 or 140)
- A32 Wideband Digital IF assembly (Option 122 or 140)
- A33 70 MHz Output assembly (Option H70)
- A34 Unpreselected Mixer (Option 123)
- A35 Unpreselected Mixer Bias Board
- A36 Microwave or Millimeter Wave Preamplifier
- A37 Audio Digitizer Assembly
- A38 Option Driver Assembly
- A39 USB/Memory Board

---

**NOTE**

Procedures for replacing assemblies are located in [Chapter 11, “Assembly Replacement Procedures,”](#) on page 305.

---

## **Battery Information**

The analyzer uses a Lithium Polycarbon Monofluoride battery to power the instrument clock. The battery is located on the CPU board. For more information, go to [“Battery Information” on page 152](#).

## **After an Instrument Repair**

If any instrument assemblies have been repaired or replaced, perform the related adjustments and performance verification tests. The adjustments and tests are done using the PSA Series Performance Verification and Adjustment Software. Refer to [Chapter 12](#) .

## Contacting Agilent Technologies

If you have a problem with your instrument, see “[Check the Basics](#)” on [page 45](#). This section contains a checklist that will help identify some of the most common problems. If further troubleshooting is necessary, continue with the troubleshooting steps earlier in this chapter, or return the instrument to Agilent Technologies.

There is also support on the world-wide web. The address is:

**<http://www.agilent.com/find/psa/>**

FAQs, firmware upgrades, documentation, and other support information can be accessed from this site.

To obtain servicing information or to order replacement parts, contact the nearest Agilent office listed in [Table 1-4](#). In any correspondence or telephone conversations, refer to the instrument by its model number and full serial number. With this information, the Agilent representative can quickly determine whether your unit is still within its warranty period.

By internet, phone, or fax, get assistance with all your test and measurement needs.

**Table 1-4 Contacting Agilent**

**Online assistance:** [www.agilent.com/find/assist](http://www.agilent.com/find/assist)

<b>United States</b> (tel) 1 800 829 4444	<b>Japan</b> (tel) (+81) 426 56 7832 (fax) (+81) 426 56 7840	<b>New Zealand</b> (tel) 0 800 738 378 (fax) (+64) 4 495 8950	<b>Europe</b> (tel) (+31) 20 547 2323 (fax) (+31) 20 547 2390
<b>Canada</b> (tel) 1 877 894 4414 (fax) (905) 282 6495	<b>Latin America</b> (tel) (305) 269 7500 (fax) (305) 269 7599	<b>Australia</b> (tel) 1 800 629 485 (fax) (+61) 3 9210 5947	

**Asia Call Center Numbers**

Country	Phone Number	Fax Number
Singapore	1-800-375-8100	(65) 836-0252
Malaysia	1-800-828-848	1-800-801664
Philippines	(632) 8426802 1-800-16510170 (PLDT Subscriber Only)	(632) 8426809 1-800-16510288 (PLDT Subscriber Only)
Thailand	(088) 226-008 (outside Bangkok) (662) 661-3999 (within Bangkok)	(66) 1-661-3714
Hong Kong	800-930-871	(852) 2506 9233
Taiwan	0800-047-866	(886) 2 25456723
People's Republic of China	800-810-0189 (preferred) 10800-650-0021	10800-650-0121
India	1-600-11-2929	000-800-650-1101

## Instrument Serial Numbers

Agilent makes frequent improvements to its products enhancing performance, usability, or reliability. Agilent service personnel have access to complete records of design changes to each type of instrument, based on the instrument's serial number and option designation.

Whenever you contact Agilent about your instrument, have the complete serial number available. This will ensure that you obtain accurate service information.

A serial number label is attached to the rear of the instrument. This label has two instrument identification entries: the first provides the identification number for each option built into the instrument and the second provides the instrument's serial number.

The serial number has two parts: the prefix (two letters and the first four numbers), and the suffix (the last four numbers). Refer to [Figure 1-2](#).

**Figure 1-2** Example Serial Number



The first two letters of the prefix identify the country in which the unit was manufactured. The remaining four numbers of the prefix identify the date of the last major design change incorporated in your instrument. The four digit suffix is a sequential number and, coupled with the prefix, provides a unique identification for each unit produced. Whenever you list the serial number or refer to it in obtaining information about your instrument, be sure to use the complete number, including the full prefix and the suffix.

## How to Return Your Instrument for Service

### Service Tag

If you are returning the instrument to Agilent for servicing, fill in and attach a blue service tag. Several service tags are supplied in this manual. Please be as specific as possible about the nature of the problem. If you have recorded any error messages that appeared on the screen, or have completed a Performance Test Record, or have any other specific data on the performance of the instrument, please send a copy of this information with the unit.

### Original Packaging

Before shipping, pack the unit in the original factory packaging materials if they are available. If the original materials were not retained, see [“Other Packaging” on page 41](#).

---

**NOTE**

Install the transportation disk into the floppy drive to reduce the possibility of damage during shipping. If the original transportation disk is not available, a blank floppy may be substituted.

---



## Other Packaging

---

**CAUTION**

Instrument damage can result from using packaging materials other than those specified. Never use styrene pellets in any shape as packaging materials. They do not adequately cushion the equipment or prevent it from shifting in the carton. They cause equipment damage by generating static electricity and by lodging in the instrument louvers, blocking airflow.

---

You can repackage the instrument with commercially available materials, as follows:

1. Attach a completed service tag to the instrument.
2. Install the transportation disk or a blank floppy disk into the disk drive. This will protect the disk drive during shipping.
3. Protect the control panel with cardboard.
4. Wrap the instrument in antistatic plastic to reduce the possibility of damage caused by electrostatic discharge.
5. Use a strong shipping container. A double-walled, corrugated cardboard carton with 159 kg (350 lb) bursting strength is adequate. The carton must be both large enough and strong enough to accommodate the instrument. Allow at least 3 to 4 inches on all sides of the instrument for packing material.
6. Surround the equipment with three to four inches of packing material and prevent the equipment from moving in the carton. If packing foam is not available, the best alternative is S.D.-240 Air Cap™ from Sealed Air Corporation, Hayward, California, 94545.  
  
Air Cap looks like a plastic sheet filled with 1-1/4 inch air bubbles. Use the pink-colored Air Cap to reduce static electricity. Wrapping the equipment several times in this material should both protect the equipment and prevent it from moving in the carton.
7. Seal the shipping container securely with strong nylon adhesive tape.
8. Mark the shipping container “FRAGILE, HANDLE WITH CARE” to assure careful handling.
9. Retain copies of all shipping papers.



---

## **2 Overall Troubleshooting**

## What You Will Find in This Chapter

This chapter provides information that is useful when starting to troubleshoot a spectrum analyzer. It includes procedures for troubleshooting common failures and provides information on isolating problems in the analyzer.

The following sections are found in this chapter:

- Initial Troubleshooting Checks .....page 45
- Troubleshooting Power-Up Problems.....page 46
- Troubleshooting Using Auto-Align Tests .....page 49
- Troubleshooting Using Front Panel Keys.....page 57

---

## Check the Basics

Before calling Agilent Technologies or returning the instrument for service, please make the following checks:

1. Is there power at the power outlet? At the power receptacle on the instrument?
2. Is the instrument turned on? Check to see if the front panel LED is green, which indicates the power supply is on.
3. If other equipment, cables, and connectors are being used with the instrument, make sure they are connected properly.
4. Review the procedure for the measurement being performed when the problem appeared. Are all the settings correct?
5. If the instrument is not functioning as expected, return the unit to a known state by pressing the **Preset** key.
6. Is the measurement being performed, and the results that are expected, within the specifications and capabilities of the instrument? Refer to the specifications book for specifications.
7. In order to meet specifications, the instrument must be aligned. Press **System, Alignments, Align All Now**. The diagnostic tests should all pass. If the instrument displays a failure during these tests, refer to [“Troubleshooting Using Auto-Align Tests” on page 49](#).
8. Check to see if the instrument has the latest firmware before starting the troubleshooting procedure. Press **System, More, Show System**. The firmware revision is listed under **Firmware Rev**. For more information, refer to [“Firmware Upgrades” on page 429](#).
9. Is the instrument displaying an error message? If so, refer to the Instrument Messages and Functional Tests guide for more information.
10. If the necessary test equipment is available, perform the functional checks in the Instrument Messages and Functional Tests guide for your instrument.
11. Use [Table 2-1 on page 46](#) to identify the instrument’s symptoms and the specific section (in this guide) which explains troubleshooting procedures for the associated symptoms.

---

## Troubleshooting Power-up Problems

---

**CAUTION**

If the instrument shows any of the following symptoms, **immediately** unplug the instrument from the ac power line:

- Smoke or unusual noise from inside the unit.
- A circuit breaker or fuse on the main ac power line opens.

These potentially serious faults must be corrected before proceeding. Refer to [“Troubleshooting Power-up Problems” on page 46](#).

---

**NOTE**

*Power-up problems include an instrument failing to boot, an instrument that completes the boot process but displays error messages, or an instrument that appears to be inoperative (dead).*

When powered up the instrument performs a boot process and CPU self-diagnostics, followed by a routine of internal auto-alignments. These tests evaluate the instrument operation; if a problem is detected an error message will be displayed, or the rear panel LEDs will indicate a problem.

**Table 2-1 Initial Symptoms**

Symptom	Troubleshooting Section
No front or rear panel LEDs	<a href="#">"Troubleshooting Power-up Problems" on page 46</a>
Blank display screen	<a href="#">"Troubleshooting Power-up Problems" on page 46</a>
Fans not operating	<a href="#">"Troubleshooting Power-up Problems" on page 46</a>
Instrument did not boot	<a href="#">"Troubleshooting Power-up Problems" on page 46</a>
Power-on auto-align tests failed	<a href="#">"Troubleshooting Using Auto-Align Tests" on page 49</a>
No response when keypad is pressed	<a href="#">"Troubleshooting Power-up Problems" on page 46</a>
Error Messages	"Instrument Messages and Functional Tests" guide
Low signal level	<a href="#">"RF Assembly Quick Check - E4440A, E4443A, E4445A" on page 75</a> For E4446A and E4448A see <a href="#">page 95</a>

## Troubleshooting an Inoperative Instrument

When the instrument appears to be dead (no display and no fans), there is often little evidence that points directly to the cause. This section provides steps and solutions to typical failure modes relating to an inoperative instrument.

### Check the Instrument Setup

Before troubleshooting the instrument, ensure that it has been set up correctly. Perform the steps in ["Check the Basics" on page 45](#).

### Initial Checks

Perform the following initial checks when first troubleshooting an inoperative instrument.

1. Check the instrument display and fans.
  - a. If the display is dark and the fans are not running, suspect a power supply or CPU problem. Refer to [Chapter 7](#), ["Troubleshooting the Processor, Power Supply, and Display," on page 145](#).
  - b. If the display is dark but the fans are running, suspect either a display problem, or a problem with the CPU boot sequence. Refer to ["Isolating a Display Problem" on page 160](#).
  - c. If the display looks good but the fans are not running, refer to ["If the Fans Are Not Operating" on page 123](#).
2. If the instrument appears to abort the boot process, experiences a failure during the self-diagnostic tests, or there is no response when a front panel key is pressed, refer to ["Troubleshooting Power-up Problems" on page 46](#).
3. Instrument powers on but does not boot:
  - a. Refer to ["Verifying the A26 CPU Assembly" on page 149](#).

4. Instrument appears to abort the boot process or experiences a failure during the self-diagnostic tests:

- a. Check for error messages.

Monitor the CPU diagnostic LED's visible on the CPU rear panel. The LED's should go through the following sequence:

- At power on, all four LED's turn on for a second.
- The left most LED turns off leaving the other three LED's on for approximately 15 seconds.
- The three LED's go off and the left LED turns on.
- The LED's go through a flashing sequence.
- All four turn on for approximately 10 seconds.
- All CPU diagnostic LED's turn off after the boot-up is complete.

5. Check for other error messages by pressing **System, Show Errors**.

---

**NOTE**

For additional information on error messages, refer to the Instrument Messages and Functional Tests manual.

---



## Troubleshooting Using Auto-Align Tests

A sequence of alignments occur automatically when the analyzer is powered on. A “pop-up” box will appear on the display indicating which alignment is being performed. In the table below, you will find a description of each auto-alignment.

**NOTE** The auto-alignment process can be aborted at any time by pressing the **ESCAPE** key.

**Table 2-2 Sequence for Auto-Align Procedures**

Procedure Name	Procedure Description
Align 2 <sup>nd</sup> LO	Locks the phase lock loop that maintains the 2 <sup>nd</sup> LO, 3.6 GHz oscillator on the A9 2 <sup>nd</sup> LO assembly. This allows the 2 <sup>nd</sup> LO to phase lock to the 600 MHz reference oscillator on the A11 Reference assembly, improving the system phase noise.  Must drive the ADC reading on the 2 <sup>nd</sup> LO to 180-220 counts. This corresponds to an error voltage of 0.5 to 0.6 volts.
Align LO	This alignment adjusts the Pretune Dac to minimize loop voltage error, and calculates the optimal Pretune DAC slope and intercept values. The values are then stored in calibration files.  Must be able to minimize loop error voltage at two different frequencies with a DAC setting between 10 and 4050.
Align 2 <sup>nd</sup> LO Pwr	Finds the DAC setting that gives an ADC reading that is equal to the ADC value written during the manufacturing process.
Rough Cal Gains	This alignment does a rough/preliminary setup of AIF main gain and RF gain to allow other alignments to function before the completion of Align AIF Main Gain and Align RF Gain. An absolute gain level is set.
Trigger Interpolator	The trigger interpolator provides a way to measure trigger timing to a fine precision. A unique trigger is used, which has timing that can be varied relative to the sample clock using an 8-bit control DAC on the A8 Analog IF. If it is not monotonic, or the expected variation is not verified, this alignment will FAIL. The A7 Digital IF assembly could be faulty also since it receives trigger inputs.
ADC Offset DAC's	Offset DAC's for each of the 4 ADC range positions on the A7 Digital IF assembly are aligned to reduce the overall DC offset.
ADC Dither CF	The ADC dither needs to be centered to prevent its own harmonics from folding back into the center of the IF passband. This routine adjusts the dither DAC on the A7 Digital IF.
ADC RAM Gains	Each of the 4 ADC range positions has its own page of RAM memory. This is a mapping of ADC bits to “output” Data bits. This RAM memory is on the A7 Digital IF assembly.  This alignment uses the 50 MHz CW calibrator signal to measure the relative response of each range page. The RF input attenuator and analog IF main gain DAC are dynamically adjusted to help keep the actual ADC signal level approximately the same.
IF Image Filter	The 321 MHz calibrator oscillator is used to align the 5 DAC's of the image filter on the A10 3rd Converter assembly.

**Table 2-2 Sequence for Auto-Align Procedures**

Procedure Name	Procedure Description
IF Gain Curve	The A8 Analog IF assembly has a gain control DAC that is called the “Main Gain”. It is used to compensate for analog IF Prefilter BW gain variations, so that the gain of the entire IF path (before ADC) remains approximately constant. It is the only gain stage that gets varied during normal instrument operation. This alignment generates the curve coefficients which characterize the gain vs. DAC number “shape” associated with this stage.
321 MHz Ampl Curve	The 321 MHz cal osc signal is used for many internal alignments. This alignment merely calibrates the amplitude control DAC for this signal, which is used by the other alignments when necessary to set accurate amplitude levels.
Comb Teeth	The relative amplitude of each of the 20 individual comb teeth is determined by comparison to the 50 MHz amplitude reference. The LO is moved to position the 50 MHz signal to the same frequency in the IF path as the comb tooth.
LC Prefilter Wide	This alignment is run for wide LC bandwidths (BW > 1.2 MHz). The 321 MHz Comb calibrator oscillator is used to align BW and CF for the analog IF LC path. Coefficients are generated for a curve that maps BW-DAC to requested BW. Another curve is generated which represents Gain vs. BW. Both of these curves are then used during Prefilter and IF gain setup during a measurement. The prefilter is located on the A8 Analog IF assembly.
LC Prefilter Narrow	This alignment is run for narrow LC bandwidths (BW ≤ 1.2 MHz). See description for LC Prefilter Wide.
XTAL Prefilter Wide	This alignment is run for wide XTAL bandwidths (BW > 20 kHz). The 321 MHz Comb calibrator oscillator is used to align BW, SYM, and CF for the analog IF XTAL path. Coefficients are generated for a curve that maps BW-DAC to requested BW. Another curve is generated which represents Gain vs. BW. Both of these curves are then used during Prefilter and IF gain setup during a measurement. The prefilter is located on the A8 Analog IF assembly.
XTAL Prefilter Narrow	This alignment is run for narrow XTAL bandwidths (BW ≤ 20 kHz). See description for XTAL Prefilter Wide.
ADC Autorange	The ADC autoranging subsystem has several hardware components that need to be setup. This alignment takes care of 3 DACs: 2 DACs on the A7 Digital IF assembly that set the positive and negative thresholds for range switches; and 1 DAC on the A8 Analog IF assembly that sets the GAIN of the autoranging detector signal. It also generates 4 gain values to be used for 4 possible measurement setups. The 4 setups cover the on/off positions of dither and analog IF post-filter. This is necessary since these positions produce different relative signal levels between the main path and the autorange path.
AIF Main Gain	This alignment derives rough values for the AIF Main Gain DAC to be used for each RF band. The front end is not measured, only the IF path. Constants set in cal files specify the amount of AIF gain desired for each band (e.g. 3 dB in band 0, 1 dB in band 1). The isolated gain of just the AIF is measured by using a detector at the AIF input to establish approximately -7 dBm input, and then measuring the power entering the digital IF with standard ADC scaling processes. The AIF gain dac is adjusted up or down until the band 0 desired gain is achieved. The AIF gain dac for all other bands is predicted (not measured) by using the band 0 value, the relative gain between bands, and the AIF gain curve (gain vs. dac) which was established by another alignment (IF GAIN CURVE). If Option B7J is present, this alignment switches DIF dither on and off, and performs calculation for electronic attenuator usage. The routine uses the 321.4 MHz Cal oscillator.
Atten Steps	Align errors of the mechanical attenuator pads at 50 MHz. If Option B7J is present, this alignment switches through the 41 electronic attenuator steps. Performs check of relative attenuator switching. When testing mechanical attenuators, this checks only the 0 dB, 10 dB AC Coupled, 10 dB DC Coupled, 12, 14, 16, 20, 30, and 40 dB steps. If the error is > 1 dB the test fails.

**Table 2-2 Sequence for Auto-Align Procedures**

Procedure Name	Procedure Description
Align RF Gain	<p>This alignment derives values for the RF Gain DAC to be used at a center frequency tuning of 50 MHz, for various system signal path setups. The RF Gain DAC in general is adjusted relative to these reference DAC values during sweeps to perform RF flatness compensation; however, at 50 MHz center frequency, the RF Gain DAC should always be exactly one of the values generated by this routine. The various system signal path setups include, but are not limited to: nominal reference path, ditherOff, and optional hardware paths (1DS and B7J) tested as part of the optional path RF Gain routine. Each path has a CAL FILE specified system gain that must be achieved (e.g. 9.8 dB nominally, 12.8 dB with ditherOff, etc.). Each path is measured using the 50 MHz AREF signal (at -25 dBm) iteratively as the RF gain DAC is adjusted up or down, until the digital IF readings indicate the correct gain has been achieved. Residual errors are recorded (e.g. 01 dB) to be applied as video shift. This alignment establishes the ABSOLUTE amplitude accuracy in the reference positions (50 MHz, DC coupled, 10 dB atten, 30 kHz RBW, 75 kHz prefilter, etc.). Because of this, it must be done near the end of the full alignment sequence, after many other system elements are aligned.</p> <p>If this alignment fails, it can be due to something in the several possible signal path setups mentioned above. The RF Gain DAC is located on the 3<sup>rd</sup> converter and controls the variable gain circuit.</p>
Align Audio Board Gain	<p>Switches in the audio board calibration signal and measures its amplitude and DC offset. If the alignment fails, assure there is no high level 10 kHz signal applied to the front panel Audio Input. An alignment failure is caused by an unseated audio board or a faulty audio board.</p>
Wide IF ADC Image (Options 122 or 140)	<p>The instrument uses the 50 MHz reference signal and compares the outputs of both A/D converters on the A31 Wideband Analog IF assembly. Internal adjustments are made to provide the best match. If this alignment fails, it can be that one of the A/D converters is faulty or the 50 MHz reference power is incorrect.</p>
Option Path RF Gain	<p>This procedure is the same as the Align RF Gain routine, where it derives values for the RF Gain DAC. However it tests the optional hardware paths:            Electronic attenuator, Option B7J            Lowband preamplifier, Option 1DS            Wideband IF assemblies, Options 122 or 140            If this alignment fails, three messages are possible:            Align_RF_Gain_Eatten,            Align_RF_Gain_Preamp,            Align_RF_Gain_WBIF.</p>
Align Variable Gain	<p>Characterizes the usable range of the RF Gain DAC setting. This allows for analog and digital gain compensations (to improve the overall amplitude accuracy of the box), used for RF flatness compensation.</p> <p>A valid DAC/gain response curve is required for this alignment to pass (30-35 dB from minimum to maximum). The DAC is located on the 3<sup>rd</sup> converter.</p>
Align LO Nulling	<p>A circuit on the A20 Lowband assembly feeds a portion of the LO signal back into the signal path that is out of phase with the LO feed through. This reduces the total LO feed through to below -65 dBm.</p>
Wide IF Step Gains (Options 122 or 140)	<p>This alignment characterizes the gain errors of the IF step gains on the A31 Wideband Analog IF assembly. The 50 MHz reference is used to make the measurements. Both filter paths on the wide band AIF are measured. If this alignment fails, it could be caused by the A31 Wideband Analog IF assembly. Check for other alignment failures also since this alignment depends on non-Option 122 or 140 assemblies such as the 50 MHz reference switch on the A14 Input Attenuator and the variable gain amplifier on the A10 Third Converter assembly.</p>

**Table 2-2 Sequence for Auto-Align Procedures**

Procedure Name	Procedure Description
Wide IF Frequency Response (Options 122 or 140)	This alignment uses the internal comb generator to perform the frequency response measurement. Step gains and filter paths are taken into account. The factory comb corrections are used for this alignment.
Trigger Delays	This alignment currently is used ONLY for delay compensation within the CDMA personality for measurements which synchronize to an “even second clock”. This alignment measures the delay of the IF path for the one particular setup used for this CDMA application.

---

## Quick Cals

Quick Cals run in the background so you don't see an on-screen indication. However they may fail and present an error message.

**Table 2-3 Quick Cals**

Quick Cal Name	Description
CURRSET_SYSTEM_GAIN (ResBW Switching)	Compares current ResBW (IFBW) with the reference BW (30 kHz) (see Align RF Gain) to determine small residual RBW switching error, usually < .1 dB.
CURRSET_IF_FREQ_RESPONSE (Narrow IF Freq Resp)	Results used for FFT sweeps and comms apps that use FFTs or demod (not for sweeps). Determines shape of Narrow Band IF and is completely analogous to Wide IF Freq Resp.

---

## Isolating the faulty assembly when the displayed amplitude is incorrect or the instrument fails a gain related Auto Align test

The PSA series analyzers contain two internal calibrators. Please refer to the instrument overall block diagram under the block diagram tab in this service guide.

The 50 MHz calibrator is located on the A10 3<sup>rd</sup> Converter, and provides a 50 MHz, -25 dBm signal to the A14 Input Attenuator. This calibration signal is used during most of the instruments auto align routine.

The 321.4 MHz calibrator signal is also generated on the 3<sup>rd</sup> Converter. This calibration signal is used for a small portion of the auto align routine and can only be manually controlled on instruments with Option B7J (Digital Demod hardware) or instruments with Option 122 or 140. Switching on the 321.4 MHz calibrator allows verification of the signal path and processing blocks from the 278.6 MHz notch filter on the 3<sup>rd</sup> Converter assembly through the A7 Digital IF assembly. The 3<sup>rd</sup> Converter is located at about the halfway point in the signal path. Therefore, checking the signal level at this point allows you to determine which half of the signal path is faulty. Instruments without option B7J require measuring the 2<sup>nd</sup> IF output port on the rear panel with another spectrum analyzer to determine which half of the signal path has a fault.

The following example illustrates how the internal calibrators and an external source can be used to identify faulty assemblies.

1. Check the internal 50 MHz calibrator amplitude on screen.

Press the green **Preset** key. Press **Mode, Spectrum Analysis**.

Press **Input/Output, Input Port, Amptd Ref, Frequency, 50 MHz, Span 1 MHz, Peak Search**. The displayed amplitude should be -25 dBm.

If the internal 50 MHz calibrator amplitude is incorrect, the calibrator may be faulty or one of the assemblies in the signal path may be faulty. To determine if the internal calibrator is faulty, perform the auto align using an external 50 MHz source connected to the PSA RF input.

Connect a source to PSA RF input. Set source to 50 MHz and -25 dBm. You should first measure the source and cable with a power meter to assure the power level is correct.

On the PSA: Press **Input/Output**, select **Input Port RF**. Press **System, More, More, Service**. To enter the password, type -49 and press the **Enter** key. Press the **Service** softkey again. Locate the **50 MHz Osc** softkey and toggle to **Ext**. This will allow the Auto Align routine to

**Isolating the faulty assembly when the displayed amplitude is incorrect or the instrument fails a gain related Auto Align test**

run using an external source rather than the internal 50 MHz calibrator.

Press **System, Alignments, Align All Now** to perform the Auto Align routine.

**If the Auto Align now passes:**

The internal 50 MHz calibrator signal is faulty.

Suspect the cable that connects the 3<sup>rd</sup> Converter to the Attenuator cal switch.

Suspect the 3<sup>rd</sup> Converter calibrator circuit. Measure 3<sup>rd</sup> Converter at J7.

Suspect the cal switch on the A14 attenuator.

Suspect the Reference Assy is not providing the 50 MHz signal (difficult to verify since the signal goes through the mother board.)

**If the Auto Align does not pass:**

Suspect gain problem in at least the low band (3 Hz to 3.05 GHz) signal path. However, you need to check the highband path (3.06 to 6 GHz) to determine if the problem is also there. To do this connect a 5 GHz, -25 dBm signal to the PSA input and tune the PSA to 5 GHz. If the problem appears in high band also, you can assume assemblies COMMON to both paths could be the source of the problem.

2. Determine if the problem is between the RF input connector and a portion of the 3<sup>rd</sup> Converter, or if the problem is somewhere between the A10 3<sup>rd</sup> Converter and A7 Digital IF output.

**Instruments with Basic Mode (Option B7J or Option 122 or 140)**

To perform this test on analyzers with Basic Mode, which is most analyzers, you will turn on the 321.4 MHz calibrator on the 3<sup>rd</sup> Converter and switch it into the signal path. When you do this, the signal path is from the 2<sup>nd</sup> IF amp on the 3<sup>rd</sup> Converter to the output of the Digital IF. This test assumes the 321.4 MHz internal calibrator is good.

Press the green **Preset** key (and factory preset if required). Press **Mode, Basic, Input/Output, Input Port**, choose **IF Align**, then press **Peak Search**. The signal level should be about -23 to -27 dBm. Notice that you did not need to set the PSA center frequency because the PSA front end is bypassed.

**If the signal level is correct:**

The signal path from the A10 3<sup>rd</sup> Converter 2<sup>nd</sup> IF Amp to the output of the A7 Digital IF is good.

The problem is somewhere between the input to the A14 Input attenuator and the 2<sup>nd</sup> IF Amp on the A10 3<sup>rd</sup> Converter.

- a. Press the green **Preset** key to turn off the 321.4 MHz internal calibrator and restore normal instrument operation.
- b. Turn on the internal 50 MHz calibrator or inject a 50 MHz, -25 dBm signal into the PSA RF input. Tune the PSA to 50 MHz. The PSA block diagram shows expected power levels at the inputs and outputs of the assembly blocks. Follow the instrument set-up instructions in the upper right hand corner of the block diagram.
- c. Measure the input signals and output signals of each circuit assembly between the Front Panel input connector and 3<sup>rd</sup> Converter until you find the wrong signal level.

**If the signal level is not correct**

The signal path from the A10 3<sup>rd</sup> Converter 2<sup>nd</sup> IF Amp to the output of the A7 Digital IF is faulty.

- a. Press the green **Preset** key to turn off the 321.4 MHz internal calibrator and restore normal instrument operation.
- b. Turn on the internal 50 MHz calibrator or inject a 50 MHz, -25 dBm signal into the PSA RF input. Tune the PSA to 50 MHz. The PSA block diagram shows expected power levels at the inputs and outputs of the assembly blocks. Follow the instrument set-up instructions in the upper right hand corner of the block diagram.
- c. Measure the input signals and output signals of each circuit assembly between the input to the 3<sup>rd</sup> Converter and test point TP5 on the A7 Digital IF.

### Instruments without Basic Mode (Option B7J or Option 122 or 140)

- a. Press the green **Preset** key.
- b. Press **Mode, Spectrum Analysis**.
- c. Turn on the internal 50 MHz calibrator or inject a 50 MHz, –25 dBm signal into the PSA RF input. Tune the PSA to 50 MHz. The PSA block diagram shows expected power levels at the inputs and outputs of the assembly blocks. Follow the instrument set-up instructions in the upper right hand corner of the block diagram.
- d. To check the signal path from the A14 Input Attenuator to the 2<sup>nd</sup> IF Amp on the A10 3<sup>rd</sup> Converter, connect a spectrum analyzer to the 321.4 MHz IF Out on the PSA rear panel and measure the 321.4 MHz output signal. The signal level should be about –30 dBm.

#### **If the signal level is correct:**

The signal path between the RF input connector and the 2<sup>nd</sup> IF Amp on the A10 3<sup>rd</sup> Converter is good.

The PSA block diagram shows expected power levels at the inputs and outputs of the assembly blocks. Follow the instrument set-up instructions in the upper right hand corner of the block diagram.

Measure the input signals and output signals of each circuit assembly between the input to the 3<sup>rd</sup> Converter and test point TP5 on the A7 Digital IF.

#### **If the signal level is not correct**

There is a problem with the signal path between the RF input connector and the 2<sup>nd</sup> IF Amp on the A10 3<sup>rd</sup> Converter.

Measure the input signals and output signals of each circuit assembly between the input connector and 3<sup>rd</sup> Converter until you find the wrong signal level. When checking the input attenuators, cycle through the attenuator steps to assure all attenuator steps are correct.



## Troubleshooting Using Front Panel Keys

Using front-panel keys, you can perform limited troubleshooting to the instrument without opening up the analyzer. The following key-driven features under the **System** key will help you diagnose the instrument:

The **Show Errors** key accesses error message information.

The **Service** key accesses an adjustment and diagnostic mode.

The **Alignments** key enables you to realign analyzer circuitry.

The **Restore Sys Defaults** key restores the analyzer to a known, “safe” state.

The **Reference** key enables you to select an internal or external reference and, if an external reference is chosen, to enter the frequency of the external reference.

Each section below begins with a list of the keys you will press to access the features in that section.

### Error Messages

Press: **System, Show Errors**

The **Show Errors** key displays the 11 most recent error messages that have been reported to the front-panel error queue. A total of 33 error messages can be stored in the error queue.

The **Next Page** and **Previous Page** keys enable you to move between the pages of the error queue.

The **Clear Error Queue** key clears the error queue. Error messages are retained in the queue, even if they are no longer detected, until the queue is cleared. The error queue is useful for troubleshooting since it records errors which may be intermittent and may not be present on the instrument display status line.

---

#### NOTE

For additional information on error messages, and for troubleshooting them, refer to the “Instrument Messages and Functional Tests Manual” (included in this instrument’s documentation set).

---

## Using Service Features

---

**NOTE** When the **Service** key is pressed, a password prompt will appear. Enter **-49, Enter** to access the Service Mode.

---

Press **Service** again to access the following keys:

- Flatness**
- Bandlock**
- 50 MHz Osc**
- LO Null**
- Noise Source**
- Diagnostics**
- 1st LO State**

### Flatness

The instrument default is **Flatness On**, and this causes the instrument to function as follows:

The System Variable Gain circuit on the A10 3<sup>rd</sup> Converter assembly provides gain to compensate for the frequency response (roll-off) of the instrument. The amount of gain needed for a given frequency point is determined by the flatness correction values stored in the instrument memory during the flatness adjustment procedure. There are thousands of correction points since additional corrections must be made for the optional Preamp and the Digital Demod Hardware states. The Variable Gain circuit also sets the level of the internal 50 MHz calibrator.

The System Variable Gain circuit cannot remove the ripple component of the frequency response. This ripple is removed with video shift on the A7 Digital IF assembly.

When **Flatness** is turned Off, the System Variable Gain is fixed at the 50 MHz setting. The video shift is turned off. The result is that the instrument displays the uncorrected frequency response of the hardware. Repair technicians can then compare the uncorrected hardware performance to the corrected performance and determine if a problem is caused by hardware, an adjustment error, or bad correction values.

### Band Lock

The **Band Lock** key tunes the first LO and sets the system gains according to the particular band that is selected. This process is needed to force the instrument to be tuned to the desired band in the frequency overlap regions.

## 50 MHz Oscillator

The **50 MHz Oscillator** key performs the internal alignment routine using a signal from the RF input (rather than the internal 50 MHz reference signal) when **Ext** is selected. **Ext** mode disables the internal 50 MHz reference oscillator and selects the RF input (when the **Align All Now** function is enabled.)

## LO Null

The LO Null circuit on the A20 Lowband assembly reduces the amplitude of the LO feedthrough that allows measurement of low level signals near the LO feedthrough signal (0 Hz). **LO Null On** is the default state.

LO Null can be used to help troubleshoot a low gain problem. Turning off the nulling so the LO feedthrough amplitude increases gives you a quick way to check that the first mixer is working. When **LO Null** is set to Off, the amplitude of the LO feedthrough should increase approximately 40-50 dB. If it doesn't, the first mixer or LO Null circuit might be defective.

## Noise Source

This key appears only if the Front End Driver assembly contains the 28V switch. Instruments with a serial prefix US4251 or MY4251 and above all contain the 28V switch. Earlier instruments may have received a Front End Driver replacement and also have the 28V switch.

Allows the 28V Noise Source Drive output on the rear panel to be turned on and off. The 28V switch is located on the A13 Front End Driver assembly.

## Diagnostics

When **HW Diag** is On, the following keys are active:

### IF Ctrl

**Main Gain DAC** - Changing the DAC value from 0 to 4095 causes about 20 dB change in displayed signal gain.

**Pre-ADC BPF** - Allows changing the bandwidth of the prefilter on the analog IF assembly. The prefilter bandwidth range is 2.5 kHz to 2.83 MHz, although the instrument display shows the upper range as 10 MHz. Above 2.83 MHz prefilter BW, the prefilter circuit switches to bypass mode and the 10 MHz wide anti-alias filter effectively sets the filtering through the analog IF assembly.

### ADC Ctrl

To view the dither signal, go to Basic mode, and set the span to 10 MHz.

**ADC Dither** - Turns dither on and off.

**ADC Dither CF** - Moves the dither center frequency in the IF. The default is 11.25 MHz relative to 7.5 MHz (center of the screen). The DAC range is 1 to 255.

**ADC Offset (7, 3, 2, 1, 0)** - Provides an offset adjustment on the NONE/direct ADC path or the manual gain path in the following amounts:

<b>ADC Offset 7</b>	offset adjustment on the NONE/direct ADC path
<b>ADC Offset 3</b>	offset adjustment on the 0 dB manual gain path
<b>ADC Offset 2</b>	offset adjustment on the 6 dB manual gain path
<b>ADC Offset 1</b>	offset adjustment on the 12 dB manual gain path
<b>ADC Offset 0 (max gain)</b>	offset adjustment on the 18 dB manual gain path

These adjustments have a DAC range of 0 to 255. ADC Offset adjustments are designed for factory use.

### ADC Range

**Auto** - The instrument automatically selects the proper ADC range based on the ranging rules in firmware.

**Auto Peak** - Allows the instrument to range up during a measurement but not range down. Allows the ADC range to automatically change to limit ADC gain (to prevent overdriving the ADC). The ADC range cannot automatically change to allow more ADC gain.

**Auto Peak Lock** - Locks in one range setting. During a measurement the ADC will not change ranges. ADC overloads could occur more easily in this mode, but the fact that the ADC range is unchanged improves the accuracy.

**Manual** - Allows front panel control of the Auto range selections: None, 0 dB, +6 dB, +12 dB, and +18 dB. The None setting bypasses the ADC range circuits. When the ADC range is changed, the noise floor level will increase with decreasing ADC gain values.

## 1st LO State

**Center Freq** - Allows the center frequency to be changed.

**1st LO Mode** - This key shows which of four possible LO modes the instrument is in.

Note: the following description assumes the instrument is in auto coupled mode (phase noise optimization under the auto coupled menu is set to Auto). The span breaks mentioned below will be different if the phase noise optimization is set manually or the sweep rate is not auto coupled.

Dual loop mode is chosen when the frequency span is  $< 2$  MHz.

Single loop mode is chosen when the frequency span is  $\geq$  to 2 MHz.

- Dual-Wide means the synthesizer is in dual-loop wide mode. If the span is  $\leq 141$  kHz the instrument is set to Dual-Wide.
- Dual-Narrow means the synthesizer is in dual loop narrow mode. If the span is 142 kHz to 1.99 MHz, the instrument is set to Dual-Narrow.
- Single-Narrow means the synthesizer is in single loop narrow mode. If the span is 2 MHz to 10 MHz, the instrument is set to Single-Narrow
- Single-Wide means the synthesizer is in single loop wide mode. If the span is  $>11$  MHz, the instrument is set to Single-Wide.

**DL Band Harm** - Dual Loop Band Harmonic. This key is greyed out unless the instrument is in dual loop mode (span  $< 2$  MHz). The Dual loop harmonic is 1 when the center frequency is set to less than approximately 6.6 GHz. The actual center frequency where band harmonic changes is based on frequency span. For span = 1.99 MHz, the instrument uses dual loop band harmonic 1 at center frequency 6.598808 GHz and band harmonic 2 at 6.5990070 GHz center frequency. DL band harmonic 4 is used from center frequency 13.3 GHz and above.

**SmpIF Start** - Shows the start frequency of the IF sampler. This can be a negative number or positive number. This frequency can be measured at J7 of the Sampler Assembly.

**SmpIF SwpDir** - Shows the Sampler IF Sweep Direction. This can be positive or negative to indicate which direction the sampler frequency sweeps or steps. A positive number means the sampler is swept or stepped higher in frequency.

## Using Alignment Features

Press: **System**, **Alignments**.

### Alignment Keys

**Auto Align**  
**Align All Now**  
**Align Subsystem**

**Align RF**  
**Align IF**  
**Align ADC**  
**Align Current IF Flatness**  
**Align Current SysGain**

**Restore Align Defaults**

### Auto Align

**Auto Align** can be set to one of three states listed below. Regardless of the auto align state, an alignment will automatically occur whenever the instrument power is cycled.

When the **Auto Align** (ON) state is selected, the instrument will automatically run all alignments in [Table 2-2](#) every 24 hours or if the internal instrument temperature changes  $\pm 3$  degrees C from the last alignment. The alignment routine is the same as if you pressed the **Align All Now**. The instrument will not sweep while the alignments are running. After the alignment routine completes, the instrument reverts back to the pre-alignment state. Therefore, if the instrument is performing a measurement and an auto align is triggered, the measurement will be interrupted, possibly causing a measurement error, until the auto align completes.

The **Auto Align** (Off) key causes neither automatic alignments nor an alert to occur.

The **Auto Align** (Alert) key causes an alert message to appear on the display when, (1), a 3 degree (Celsius) change in temperature is detected, or (2), at 24 hour intervals. The message will prompt you to perform an alignment, but no alignment will occur automatically.

---

#### NOTE

An annotation at the left side of the screen that reads “AA” will appear when the **Auto Align** On or Alert features are active.

---

### **Align All Now**

The **Align All Now** key halts normal analyzer operation and forces a complete realignment of the entire system.

When performing any alignment, the presence of an external 50 MHz signal is checked. If an external 50 MHz signal  $> 0$  dBm, is detected, the alignment routine will be skipped and the message “High 50 MHz power level” will be displayed. If this occurs, remove the 50 MHz signal from the analyzer input and perform **Align All Now** or **Align Subsys, Align RF**.

### **Align Subsystem**

The **Align Subsys** key allows you to align the RF, IF, and ADC circuitry of the analyzer for amplitude accuracy by activating the **Align RF**, **Align IF**, and **Align ADC** keys. You can also align the current IF flatness and the system gain of the analyzer (explained below).

The **Align Current IF Flatness** key activates an immediate measurement of the current IF flatness.

The **Align Current SysGain** key activates a fine-tuning of the system gain. This adjustment is done by measuring the response of the current system state configuration to the 50 MHz amplitude reference signal. All subsequent measurements are then compensated appropriately for absolute amplitude accuracy.

### **Restore Align Defaults**

The **Restore Align Defaults** key loads the default values for system alignments, turns on frequency corrections, and resets the timebase to the factory set values.

## Selecting the Frequency Reference

Press: **System, Freq Ref**

The **Freq Ref** key allows you to toggle the reference from internal to external (or external to internal), and then specify the external reference frequency, by entering a value between 1 and 30 MHz, followed by pressing the **Enter** key.

The **10 MHz Out** key activates or deactivates the 10 MHz reference out signal on the rear panel of the analyzer.

## User Diagnostics

Press: **System, More, Diagnostics, Front Panel Test**

The Front Panel Test allows key presses and RPG knob rotations to be displayed on the instrument's screen. This diagnosis is useful when checking the functionality of all keys and the RPG knob.

## Restore System Defaults

Press: **System, More, Restore Sys Defaults**

Pressing this key sets the following back to the factory defaults:

### **Power On/Preset**

— **Power On** is set to Preset.

— **Preset Type** is set to Mode.

**Auto Align** is set to On.

**Freq Ref** is set to Internal.

**10 MHz Out** is set to Off.

**Color Palette** is set to Default.



## Troubleshooting Performance Test Failures

This information assumes the analyzer is making measurements but a performance test is failing by a small margin, or only a few measurements are failing. If most of the performance tests are failing, go to ["Check the Basics" on page 45](#).

**Step 1.** Determine if an adjustment is causing the analyzer to fail the performance test.

Do the adjustments, if any, associated with the failing performance test.

**Step 2.** Determine the probable faulty assembly by comparing the performance test results to [Table 2-4](#).

<b>NOTE</b>	Please note that a failure on any assembly in the input RF path could cause many of the performance tests to fail. See the Overall Block Diagram in <a href="#">Chapter 9</a> .
-------------	---

[Table 2-4](#) lists the assembly or assemblies most likely to cause the failure. Multiple probable faulty assemblies are listed in order of probability.

**Table 2-4      Performance Test Failures**

Failing Performance Test	Adjustment	Probable Faulty Assembly	Troubleshooting Information
Residual Responses	None	RF Section - cables and assemblies	<a href="#">Chapter 3</a> <a href="#">Chapter 4</a>
Displayed Average Noise Level (DANL)	2nd LO Power Lowband Mixer Bias SLODA/FELOMA	RF Section A8 Analog IF/ A31 Wide Analog IF A10 3rd Converter A19 RYTHM A20 Lowband A22 Preamp	<a href="#">Chapter 3</a> <a href="#">Chapter 4</a> <a href="#">Chapter 6</a>
Frequency Reference Accuracy	10 MHz Internal Frequency Reference	A11 Reference	<a href="#">Chapter 5</a>
Frequency Readout Accuracy	10 MHz Internal Frequency Reference	A11 Reference	<a href="#">Chapter 5</a>
Count Accuracy	10 MHz Internal Frequency Reference	A11 Reference	<a href="#">Chapter 5</a>

**Table 2-4 Performance Test Failures**

<b>Failing Performance Test</b>	<b>Adjustment</b>	<b>Probable Faulty Assembly</b>	<b>Troubleshooting Information</b>
Spurious Responses	None	A19 RYTHM FL1 (3 GHz LPF) FL2 (3.9214 GHz BPF) A20 Lowband A10 3rd Converter A8 Analog IF	<a href="#">Chapter 5</a> <a href="#">Chapter 3</a> <a href="#">Chapter 4</a> <a href="#">Chapter 6</a>
Images and Spurious Responses (Wide IF) <i>But not failing the normal Spurious Responses test</i>		A31 Wideband Analog IF	<a href="#">Chapter 8</a>
Second Harmonic Distortion	Lowband Mixer Bias	A13 Front End Driver A19 RYTHM A20 Lowband	<a href="#">Chapter 3</a> <a href="#">Chapter 4</a>
Third-Order Intermodulation Distortion	Second LO Power Lowband Mixer Bias SLODA/FELOMA	A19 RYTHM A20 Lowband A10 3rd Converter	<a href="#">Chapter 3</a> <a href="#">Chapter 4</a>
Third-Order Intermodulation Distortion (Wide IF) <i>But not failing the normal TOI test</i>		A31 Wideband Analog IF	<a href="#">Chapter 8</a>
Gain Compression	Second LO Power Lowband Mixer Bias	A20 Lowband A10 3rd Converter A19 RYTHM	<a href="#">Chapter 3</a> <a href="#">Chapter 4</a>
Power Bandwidth Accuracy	None	A8 Analog IF A7 Digital IF	<a href="#">Chapter 6</a>
IF Amplitude Ripple	None	A8 Analog IF/ A31 Wideband Analog IF A10 3rd Converter	<a href="#">Chapter 6</a> <a href="#">Chapter 3</a> <a href="#">Chapter 4</a>
IF Phase Ripple	None	A12 Synthesizer	<a href="#">Chapter 5</a>
Input Attenuation Switching Uncertainty	None	A14/A15 Input Attenuators A13 Front End Driver The A8 Analog IF or A7 Digital IF assemblies may have come unseated. Assure these assemblies are fully inserted in the motherboard.	<a href="#">Chapter 3</a>
Display Scale Fidelity	None	A7 Digital IF A8 Analog IF	<a href="#">Chapter 6</a>

**Table 2-4 Performance Test Failures**

<b>Failing Performance Test</b>	<b>Adjustment</b>	<b>Probable Faulty Assembly</b>	<b>Troubleshooting Information</b>
Absolute Amplitude Accuracy	Second LO Power SLODA/FELOMA 50 MHz Calibrator Amplitude	A14/A15 Input Attenuators A20 Lowband A10 3rd Converter A8 Analog IF A7 Digital IF A19 RYTHM A30 FIFA (44 - 50 GHz) A18 YTO A29 SBTX/FELOMA Driver (44 - 50 GHz)	<a href="#">Chapter 3</a>
Absolute Amplitude Accuracy (Wide IF)  <i>But not failing the normal Absolute Amplitude Accuracy test</i>		A10 3rd Converter A31 Wideband Analog IF	<a href="#">Chapter 8</a>
Noise Sidebands	None	A12 Synthesizer A11 Reference A9 Second LO A18 YTO	<a href="#">Chapter 3</a> <a href="#">Chapter 4</a> <a href="#">Chapter 5</a>
Frequency Response  (check description of test to determine instrument settings such as Preamp ON, Preselector On or OFF)	SLODA/FELOMA YTF Align Attenuator Slope Frequency Response	A20 Lowband A19 RYTHM A22 Preamp A27 Electronic Attenuator A14/A15 Input Attens A10 3rd Converter A13 Front End Driver RF Section	<a href="#">Chapter 3</a> <a href="#">Chapter 4</a>
Resolution Bandwidth Switching Uncertainty	None	A8 Analog IF A7 Digital IF	<a href="#">Chapter 6</a>
LO Output Accuracy (Opt. AYZ)	LO Output	A21 SLODA A21 FELOMA A13 Front End Driver	<a href="#">Chapter 3</a> <a href="#">Chapter 4</a>
IF Input Accuracy (Opt. AYZ)	IF Input	A10 3rd Converter	<a href="#">Chapter 6</a>
Preselector Tune Out (Opt. AYZ)	Preselector Tune Out	A13 Front End Driver	<a href="#">Chapter 6</a>

**Table 2-4**      **Performance Test Failures**

<b>Failing Performance Test</b>	<b>Adjustment</b>	<b>Probable Faulty Assembly</b>	<b>Troubleshooting Information</b>
Input Noise Density (Wide IF) <i>But not failing the DANL test</i>		A31 Wideband Analog IF A10 3rd Converter	<a href="#">Chapter 8</a>

---

# **3      Troubleshooting the RF Section (E4440A, E4443A, E4445A)**

---

## What You Will Find in This Chapter

The following information is found in this chapter:

1. Theory of operation of the RF section for model numbers E4440A, E4443A, and E4445A.
2. Isolating the cause of a hardware problem by verifying the functionality of assemblies in the RF section signal path.
3. Block diagrams of the RF section of the analyzer.

---

**NOTE**

*Each section describes how the assembly works and gives information to help you troubleshoot the assembly. Each description covers the purpose of the assembly, describes the main components, and lists external connections to the assembly.*

---

This following descriptions are found in this chapter:

- [RF Section Description \(E4440A, E4443A, E4445A\)](#) .....page 71
- [Overall Front End](#) .....page 75
- [A14 and A15 Step Attenuators](#) .....page 76
- [A21 Switched LO Distribution Amplifier \(SLODA\)](#) .....page 78
- [A19 RYTHM](#) .....page 80
- [A18 YTO](#) .....page 81
- [A20 Lowband](#) .....page 82
- [A13 Front End Driver](#) .....page 84
- [A22 Low Band Preamplifier \(Option 1DS\)](#) .....page 86
- [A27 Electronic Attenuator Description \(Option B7J\)](#) .....page 87

## RF Section Description (E4440A, E4443A, E4445A)

### Purpose

The RF front end section converts input signals to a 3<sup>rd</sup> IF of 21.4 MHz. This section contains assemblies which generate Local Oscillator (LO) signals and assemblies which use the LO signals to mix the RF Input and the subsequent IF signals. Assemblies in the RF section also provide attenuation and circuit protection, gains and trigger signals, and a path for the 50 MHz calibrator signal.

### RF Block Diagram (E4440A Example)

The 3 Hz to 26.5 GHz RF input signal first enters the input attenuators, A14 and A15. The input attenuators provide 0 to 70 dB attenuation in 2 dB steps. In addition, a selectable DC block and a switch for the calibrator signal are contained in the input attenuator block. With the DC block switched in (AC coupling), the frequency range is limited to 20 MHz to 26.5 GHz. The calibrator path supports a 50 MHz, -25 dBm signal for absolute amplitude calibration.

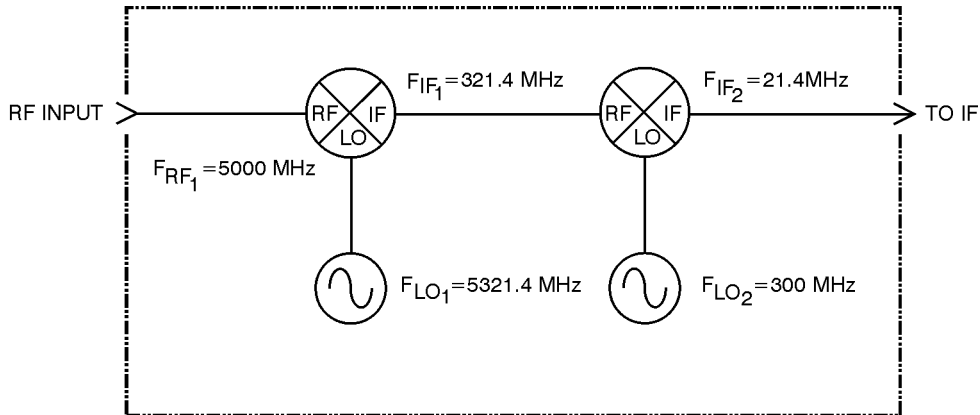
After passing through the input attenuators, the RF signal routes to one of two major RF paths; High Band for frequencies above 3 GHz and Low Band for frequencies below 3 GHz. The A19 RYTHM (Routing YIG-Tuned Harmonic Mixer) is where the two major RF paths diverge.

For the High Band path, the signal continues through the RYTHM where it first passes through the YIG Tuned Filter (YTF). The YTF tracks the displayed center frequency as the instrument sweeps and removes spurious signals such as images and multiples. Next the signal is down-converted to the 321.4 MHz IF using the harmonically-pumped High Band mixer. The IF signal then routes out of the RYTHM and into the Third Converter board.

For the Low Band path, the 3 Hz to 3 GHz signals leave the input switch in the RYTHM and continue through to the FL1 3 GHz Lowpass filter. If the instrument contains Option 1DS (preamplifier) or Option B7J (digital demod hardware), the low band signal also routes through them. The signal then enters the A20 LowBand assembly.

The Lowband assembly contains both the first and second mixer. The first mixer up-converts the RF signal to the 3.9214 GHz first IF. The first IF signal leaves the Lowband assembly and routes through the 3.9214 GHz bandpass filter FL2, and back into the Lowband assembly at the first IF input port. The second mixer down-converts the first IF to the 321.4 MHz second IF. The second IF signal then routes to the A10 Third Converter assembly.

**Figure 3-1 Example of Down Conversion**

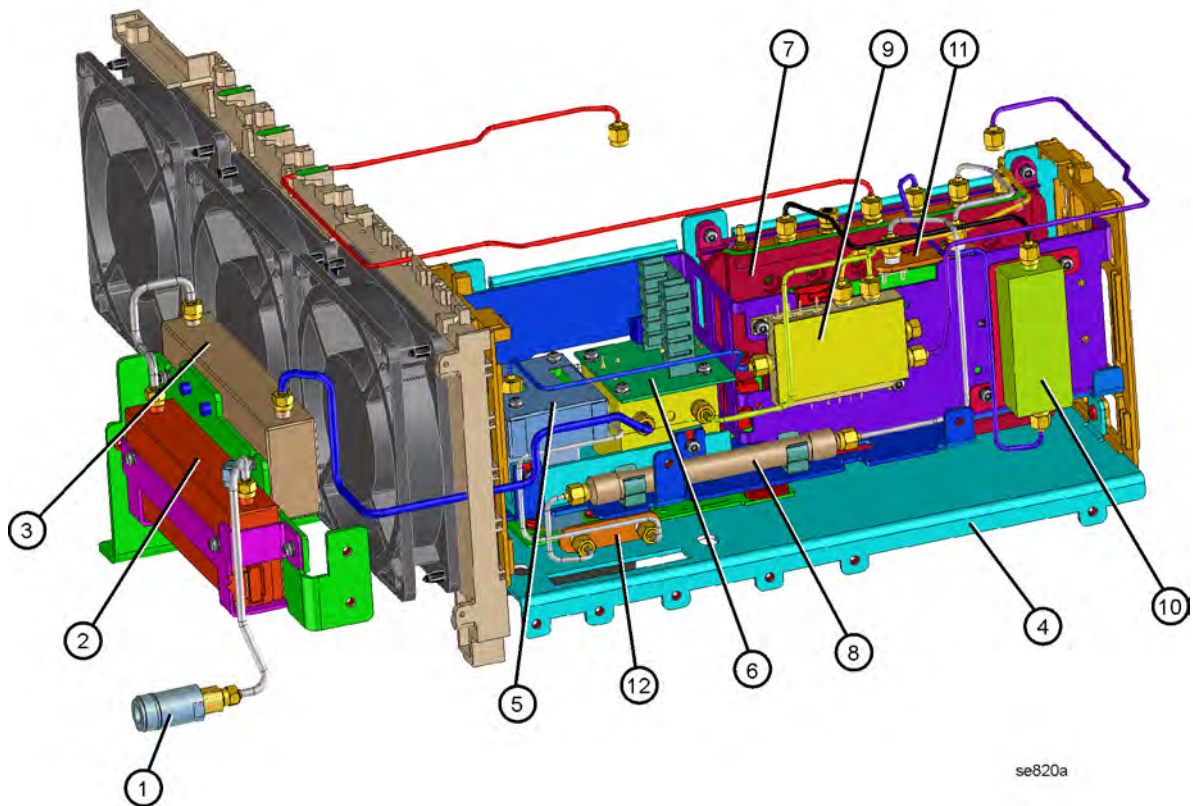


se861a

In the Third Converter, one of three possible 321.4 MHz IF signals is selected: High Band, Low Band, and 321.4 MHz from an optional 321.4 MHz input. The 321.4 MHz is fed to the system variable gain which is used to establish gain at 50 MHz as well as remove front end frequency response as the instrument tunes across it's frequency range. The third mixer down-converts the 321.4 MHz second IF to the 21.4 MHz IF.



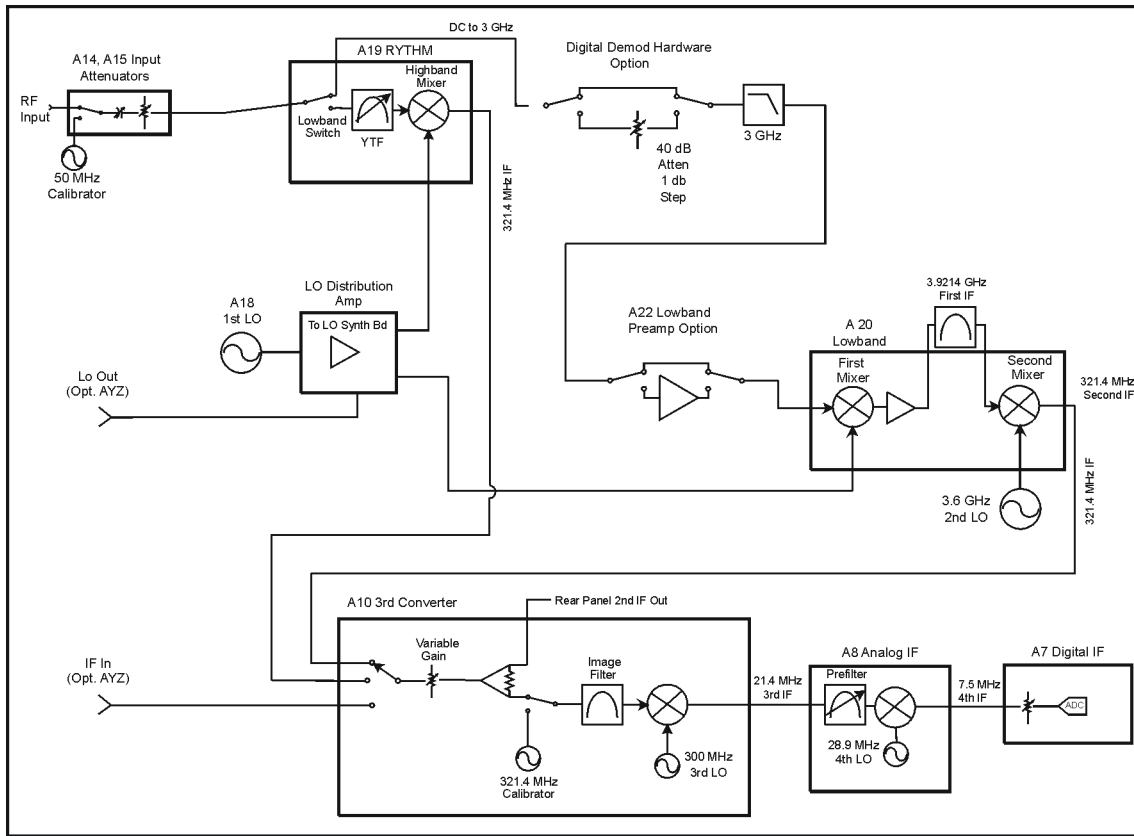
**Figure 3-2 RF Section Assemblies - E4440A, E4443A, E4445A**



se820a

Item	Description
1	J1 Input Connector
2	A14 Attenuator/Switch
3	A15 Attenuator
4	L-bracket, RF Main
5	A18 YTO, 2.9 to 7 GHz (Yig Tuned Oscillator)
6	A19 RYTHM
7	A20 Low Band Assembly
8	FL1 Low Pass Filter, 3 GHz
9	A21 SLODA (Switched LO Distribution Amplifier)
10	FL2 Band Pass Filter, 3.9214 GHz
11	A22 Preamp Assembly (Option 1DS)
12	A27 Electronic Attenuator (Option B7J)

**Figure 3-3 Block Diagram with RF Options - E4440A, E4443A, E4445A**



- Option BAB**  
 (E4440A only) - APC 3.5 mm input connector. Standard PSAs use a precision machined Type N connector for the RF input.
- Option B7J** - Digital Demod Hardware. The electronic attenuator works over the lowband frequency range. In bypass mode, the coax switches in the electronic attenuator board route the RF signal on through to the Lowband board. The electronic attenuator path consists a 40 dB, 1 dB step solid state attenuator.
- Option 1DS** - Low Band Preamp. In bypass mode, the coax switches route the Low Band RF signal on to the Lowband assembly. When in preamp mode the 30 dB gain, low noise figure amplifier path is selected.
- Option AYZ**  
 (E4440A only) - External Mixing. Allows an external preselected or unpreselected mm wave mixer to be used with the instrument.

## RF Assembly Quick Check - E4440A, E4443A, E4445A

---

**NOTE**

---

To perform the following checks, it will be necessary to remove the outer case and the top brace. See [Chapter 11](#) for removal procedures.

Turn the instrument on and allow it to complete its internal calibration routines. This routine will generate error messages if the signal level is incorrect through the system. Inject the 50 MHz, -25 dBm calibrator signal to the RF Section by pressing **Input/Output, Input Port, Amptd Ref** (f = 50 MHz). Set the instrument to CF = 50 MHz, Span = 0 Hz, and the input attenuator to 10 dB.

Disconnect the cable with the “3” color band from the third converter 21.4 MHz output A10J5. Connect the RF Input of another spectrum analyzer to A10J5. A 21.4 MHz, -27 dBm  $\pm$ 2 dB signal should be present.

### Verifying a Faulty Front End Assembly E4440A, E4443A, E4445A

#### Overall Front End

Finding a fault in the RF front end is best done by breaking the path and monitoring the signal level and frequency with another spectrum analyzer. The signal levels and frequencies are noted on the overall block diagram foldout for given input conditions. In following the first LO, breaking the signal path between the A18 YTO and the A21 SLODA, or at the Sampler Output of the SLODA, will cause an unlock condition. This can be resolved by using a power splitter to keep the loop complete and yet facilitate measurement. In doing this, the measured signal level due to loss of the splitter must be taken into account.

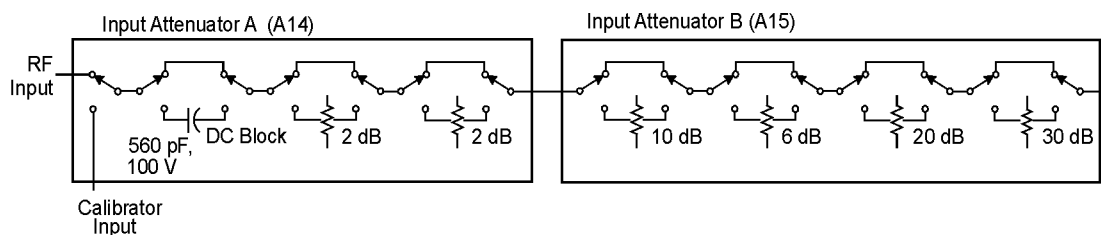
Since most RF section assemblies are expensive, a suspected faulty assembly should be verified by checking bias voltages and input signals before replacing them. This is best accomplished by improving accessibility of the test points and nodes on the A13 Front End assembly by using the extender boards and cables supplied in the Service Kit E4440-60090. For troubleshooting the RF Section, use the following pieces supplied in the kit:

A13 Front End Driver Extender	E4440-60049
A13J12 Bias Board	E4440-60041

### A14 and A15 Step Attenuators

A faulty attenuator can cause improper signal level in both High and Low bands, often in certain combinations of attenuator settings. In addition, a faulty A14 can prevent the frequency range from going down to 3 Hz, even when the PSA is set in DC Coupled mode. A14 can also prevent the 50 MHz calibrator signal from being displayed.

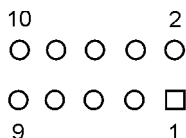
**Figure 3-4 Attenuator Block Diagram**



se824a

The attenuators receive control signals and supplies from the A13 Front End Driver assembly. A14 is fed from A13J3 and A15 is fed from A13J4. Ground is on pin 3 and the 25V supply is on pin 10. Viewing from the circuit side of the board, the connector pinouts are shown:

**Figure 3-5 Connector Pinout**



se825a

If the 50 MHz calibrator signal is not displayed, first verify its presence at A14J2. Disconnect the gray W20 cable from the attenuator and monitor the signal coming out of the cable with another spectrum analyzer. The signal should be 50 MHz at  $-25$  dBm. Verify that the attenuator is receiving the proper TTL signals monitoring the points on A13J3 with a scope using the truth table.

Input Path	Calibrator Path Select J3 pin 2	Calibrator Path Bypass J3 pin 1
RF	High	Low
Calibrator	Low	High

If the DC/AC Coupling modes are not properly functioning, a similar table can be used.

Coupling	DC Block Select J3 pin 9	DC Block Bypass J3 pin 4
DC	High	Low
AC	Low	High

Improper displayed signal amplitudes in some attenuator settings can be isolated to either A13 or A14 based on which steps are incorrect. Signal out of the attenuators can be measured by disconnecting the appropriate semirigid cable and using a spectrum analyzer. Referring to [Figure 3-4](#), A14 has two 2 dB sections and A15 has a 6 dB, a 10 dB, a 20 dB and a 30 dB section. Verify that the attenuators are receiving the correct switching sequences by using the following tables.

**Table 3-1 A15 Settings**

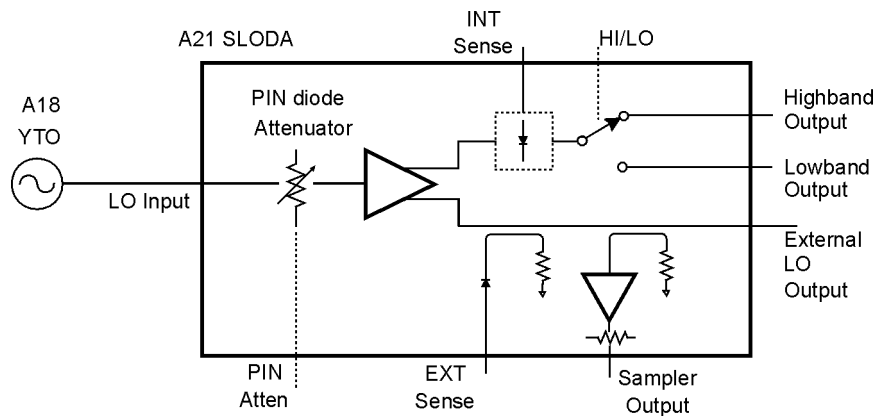
Attenuation (dB)	6 dB Select J4 pin 9	6 dB Bypass J4 pin 4	10 dB Select J4 pin 2	10 dB Bypass J4 pin 1	20 dB Select J4 pin 8	20 dB Bypass J4 pin 5	30 dB Select J4 pin 7	30 dB Bypass J4 pin 6
0	High	Low	High	Low	High	Low	High	Low
6	Low	High	High	Low	High	Low	High	Low
10	High	Low	Low	High	High	Low	High	Low
20	High	Low	High	Low	Low	High	High	Low
30	High	Low	High	Low	High	Low	Low	High
40	High	Low	Low	High	High	Low	Low	High
50	High	Low	High	Low	Low	High	Low	High
60	High	Low	Low	High	Low	High	Low	High
70	Low	High	Low	High	Low	High	Low	High

**Table 3-2 A14 Settings**

Attenuation (dB)	2 dB_A Select J3 pin 8	2 dB_A Bypass J3 pin 5	2 dB_B Select J3 pin 7	2 dB_B Bypass J3 pin 6
0	High	Low	High	Low
2	Low	High	High	Low
4	Low	High	Low	High
6	High	Low	High	Low
8	Low	High	High	Low
10	High	Low	High	Low

**A21 Switched LO Distribution Amplifier (SLODA)**

**Figure 3-6 SLODA Block Diagram**



se826a

The A21 SLODA provides amplitude leveling and distribution of the 3 to 7 GHz first LO signal to the RYTHM, Lowband assembly, and LO Synthesizer Board (Sampler output). The External LO Output is terminated in 50 Ohms.

The 3 to 7 GHz LO signal enters the SLODA from the YTO. The ALC circuit on the A13 Front End Driver provides level control via the PIN Atten line. The ALC circuit receives its input from the SLODA's INT Sense line. The A13 also provides the RYTHM band and Low Band switching information as well as Gate Bias.

Some common symptoms of a faulty SLODA include YTO Unlock errors, Sampler errors, LO Unleveled errors, low signal level in one or both bands, spurious signals or high DANL. To verify a faulty SLODA, first check that the YTO signal is present at the YTO IN connector. The

signal should be 3 to 7 GHz at +12 to +17 dBm. Next verify the LO outputs, all of which range from 3 to 7 GHz. To verify the High Band output, set the PSA to a center frequency of 5 GHz and set the span to 0 Hz. The High Band LO Output should be 14.5 dBm  $\pm$ 3 dB. Verify the Low Band LO output by setting the PSA to a frequency below 2.85 GHz in zero span, and verify that the signal is 14.5 dBm  $\pm$ 1 dB. The signal at the SAMPLER OUT should range from -8 dBm to -3 dBm and the 1<sup>st</sup> LO OUT should be around 15 dBm.

**NOTE**

The DC voltages on the SLODA can be measured either at the connectors to the SLODA, or at A13J12 using the E4440-60041 bias board (included in Service Kit E4440-60090). Measuring at the SLODA will help verify the condition of the A13-to-SLODA bias cable, W28.

If either the Low Band or High Band outputs are bad, check that the band switch is being driven properly. To set the PSA to Low Band, set the Center Frequency below 2.85 GHz in Zero Span. Set the analyzer above 3 GHz for High Band. A DVM with a fine probe can be used to reach the connections at the SLODA. Connect the negative lead to A13 TP11, or to A13J12 pin 10 (SLODACOM) if the bias board is available.

SLODA Pin	High Band	Low Band
SW A	-1 V	1 V
SW B	1 V	-1 V

Using a DVM, verify that the Gate Bias is close to the value printed on the SLODA label. If probing on A13J12, measure at pin 9 (GATE BIAS on the bias board.)

For the ALC, verify that the Level Adj pin reads between -0.5 V to -3 V. INT Sense can be measured at A13J12 pin 8 (INT SENSE on the bias board) as well as at the SLODA. With the E4440 in Zero Span, set the Center Frequency to the frequencies listed and measure the INT Sense voltages. They should be close to the values printed on the SLODA label for each band.

Band	Frequency Range
B0	30 Hz to 3 GHz
B1	2.85 GHz to 6.6 GHz
B2	6.2 GHz to 13.2 GHz
B3	12.8 GHz to 19.2 GHz
B4	18.7 GHz to 26.5 GHz

EXT Sense is used when Option AYZ External Mixing, or Option 123, Unpreselected Path is installed. EXT Sense line goes to the Front End Driver assembly and is MUX'd into the SLODA LO levelling loop.

## A19 RYTHM

RYTHM stands for Routing YIG Tuned Harmonic Mixer. This is the first mixer for the preselected high bands, bands 1 through 4. Three major components make up RYTHM: the input switch, YIG preselected bandpass filter, and the harmonic mixer.

Included with the RYTHM Driver PC board which includes the current source for the YTF coil as well as bias circuitry for the ODD/EVEN IF Switch as well as the input switch. The ODD/EVEN IF switch optimizes conversion loss for different harmonic mixing bands. A TTL high on L\_ODD\_IF from the Front End Driver board is used for bands 2, 3, and 4. A TTL low on L\_ODD\_IF is used for band 1. TTL levels on L\_RYTHM\_LB select the RF input switch position in RYTHM: low for Low Band position and high for High Band position.

The RYTHM bands are bands 1 through 4 whose start (minimum) and stop (maximum) frequencies are shown in the following table:

Band	Minimum Frequency	Maximum Frequency
1	2.85 GHz	6.6 GHz
2	6.2 GHz	13.2 GHz
3	12.8 GHz	19.2 GHz
4	18.7 GHz	26.5 GHz

The mixing equations are:

$$\text{Band 1} \quad F_{LO} = F_{RF} + F_{IF}$$

$$\text{Band 2} \quad F_{LO} = (F_{RF} + F_{IF})/2$$

$$\text{Band 3, 4} \quad F_{LO} = (F_{RF} + F_{IF})/4$$

$$F_{IF} = 321.4 \text{ MHz}$$

RYTHM uses the 1, 2 and 4<sup>th</sup> harmonic of the LO. The RF is always on the low side of the LO harmonic. Note that band 3 and band 4 use the 4<sup>th</sup> LO harmonic. The artificial band break between band 3 and band 4 allows for the YTF tuning curve and the frequency response curve to more approximate straight line segments.

The PSA uses independent ramp generation circuits for the YTO and YTF. The YTF's center frequency is a near linear function of the tuning current. A YTF voltage ramp generator is contained on the A13 Front End Driver Board and the YTF current source is contained on the RYTHM PC board. The voltage ramp feeds both the RYTHM microcircuit as well as the PRE-SEL Tune Output port on the back panel. The YTF is specified to have a tuning sensitivity range of 41 to 49 MHz/mA.



Common failures with RYTHM are a damaged input switch due to input overstress, and a faulty preselector. The former can cause signal loss in either High Band or Low Band, or in both. The latter will cause signal loss or flatness problems in High Band only.

Whenever a RYTHM is suspected, first check presence of the  $-15\text{VF}$  bias at A13J6 pin 5, and  $+15\text{VF}$  at A13J6 pin 7 using a DVM. Connect the negative lead of the DVM to A13 TP8. Voltages and signals coming from A13J6 should also be checked at the RYTHM to verify W28. Check that the LO from A18 through W35 is present using another spectrum analyzer. Also check the input signal coming through W9 from the attenuator. (The signal level will be the input level less the attenuator settings.) If you are using the internal 50 MHz calibrator signal, make sure that it is switched in.

If the signal is corrupted in Low Band only, make sure that the input switch is being controlled after verifying presence of the input signal. HIBAND should be a TTL high in High Band and low in Low Band.

If the signal is not getting through the preselector, first check the band switching per the above paragraph. Try manually peaking the signal by pressing **AMPLITUDE**, **Presel Adjust**. If the signal can be peaked, the flatness adjustment may be needed or the A13 is faulty. A faulty RYTHM is least likely in this scenario. Next check the presence of a tune ramp. Set the start and stop frequencies to 3 GHz and 26.5 GHz respectively with the PSA in continuous sweep. (This generates a ramp to tune the preselector nearly through its entire range.)

The A13 YTF tune circuitry can be quickly verified by looking for a combination of steps and ramps ranging from approximately 0 to 5 volts with an oscilloscope on the rear panel PRE-SEL OUT connector. The period of this waveform will vary with the sweep time. Also verify that  $+VTUNE$  is being applied to the RYTHM at A13J6 pin 13. A similar ramp ranging up to about 2.5 volts should be observed.

### A18 YTO

The YTO (YIG-Tuned Oscillator) supplies the raw 3 to 7 GHz LO signal. Verify that its output is from  $+12\text{ dBm}$  to  $+17\text{ dBm}$ . With a DVM, verify the presence of the supplies on the A13 Front End Driver:

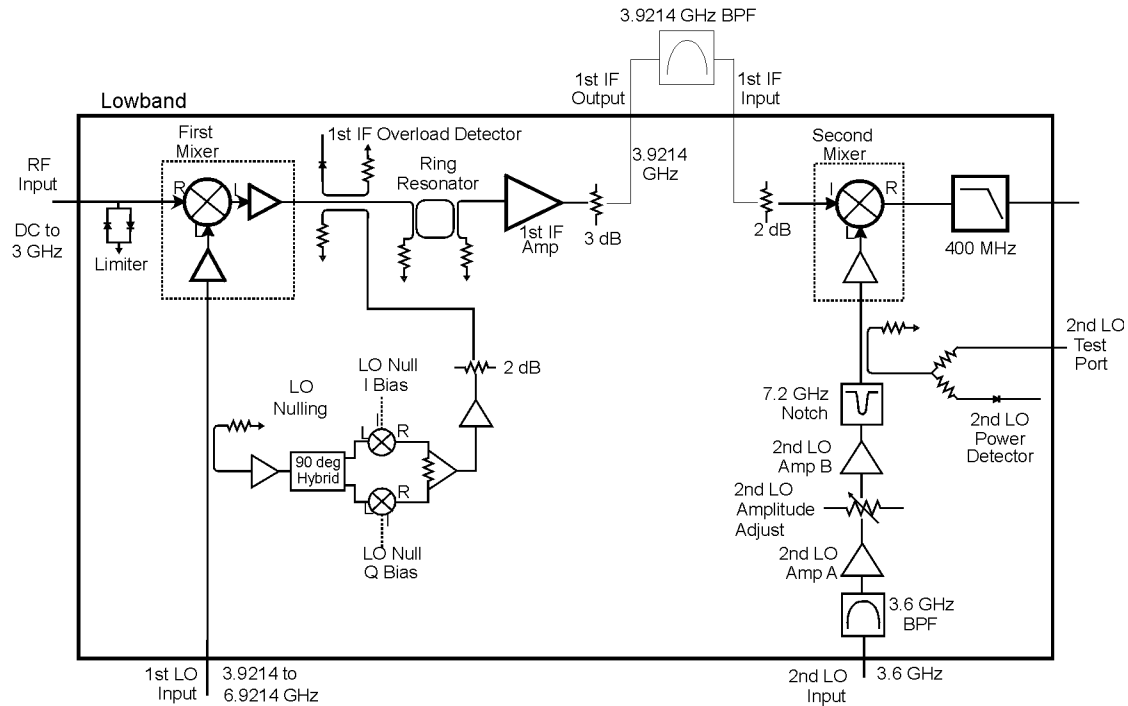
<b>J7 Pin 4</b>	<b>J7 Pin 5</b>	<b>J7 Pin 7</b>	<b>J7 Pin 9</b>
+15 V	$-5\text{ V}$	+15 V	+15 V

Common symptoms of a faulty YTO are YTO Unlock errors, spurious signals, and low signal level at all frequencies. Two current-driven coils are used to tune the YTO. Both coils are used in all spans. The coil drivers are on the A12 LO Synthesizer assembly and the signals route through the A13 Front End Driver.

### A20 Lowband

The Lowband assembly is the front end converter for frequencies below 3 GHz. The Lowband assembly encompasses both the first and second mixers, the 2<sup>nd</sup> LO multiplier, LO Nulling and filtering.

**Figure 3-7 Lowband Assembly Block Diagram**



se827a

Mixing equation:  $F_{LO} = F_{RF} + F_{IF}$   
 $F_{IF} = 3.9214 \text{ GHz}$

The 3 Hz to 3 GHz RF input signal enters the Lowband assembly at A20J1. The first component in the RF path is the RF Limiter. This limiter prevents excessive RF energy from damaging the first mixer. The first mixer up-converts the 3 Hz to 3 GHz signal to the 3.9214 GHz first IF. The first LO, which enters the Lowband assembly from the SLODA, ranges from 3.9214 to 6.9214 GHz. Following the first mixer is a dual coupler. One output of the coupler routes to the first IF overload detector and the other coupler port is the input from the LO Nulling circuit. The next stage in the first converter section is the First IF Amplifier. Following the First IF Amplifier, the first IF signal leaves the Lowband assembly, routes through the external first IF bandpass filter and re-enters the Lowband assembly in the Second Converter section. The second mixer down-converts the 3.9214 GHz first IF to the 321.4 MHz second IF. The second LO is at 3.6 GHz. Following the

second mixer is the second IF lowpass filter.

LO Nulling is the process of reducing the LO feedthrough signal that appears on screen when the instrument is tuned to 0 Hz. When tuned to 0 Hz, the first LO is at 3.9214 GHz. The LO Nulling circuitry works around this frequency and adds a signal of approximately-equal amplitude, but 180 degrees out of phase. This signal is coupled off the main LO path.

A faulty Lowband assembly will commonly cause low or no signal below 3 GHz, and no LO Nulling. The 3.6 GHz second LO signal is supplied by the A9 Second LO assembly. The second LO is amplified in the Lowband assembly before it is applied to the Second Mixer

A failure with the Lowband assembly will likely result in a problem with signals up to 3 GHz only. First check for a signal at the input, A20J1, the First LO at A20J2, and the 2<sup>nd</sup> LO at A20J5 by referring to the signal conditions given on the overall block diagram. The multiplied 2<sup>nd</sup> LO can be checked at A20J6. Similarly the first IF signal can be verified at A20J3.

With the PSA set to a center frequency below 3 GHz, and in zero span, check that the bias voltages are present. Some of these can be accessed on the A13J12 Test Connector and some others have test points. With the negative lead of the DVM on A13J12 pin 6, look for values listed in the table.

---

**CAUTION**

---

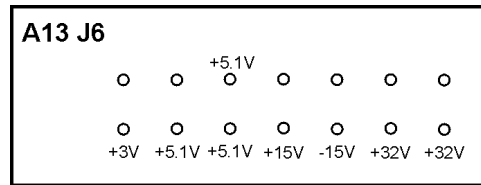
Use care when probing connector pins on A13, especially on A13J8. Connector spacings are close and shorting nodes can cause damage.

Pin/ Name	Nominal Voltage
A13J12 pin1/-5V_LB	-5 V
A13J12 pin2/-5V_M1LO	-5 V
A13J12 pin3/-5V_M1IF	-5 V
A13J12 pin4/-5V_M2IF	-5 V
A13J8 pins 7,8/+3V_LB	3 V
A13J8 pin25/+5.2V_LB	5.2 V
A13TP22/M1LO_ADJ	100 mV
A13TP23/M1LO_ADJ	150 mV
A13TP24/M2LO_ADJ	100 mV
A13J8 pin16/+10V_LB	10 V
A13TP26/LO_NULL_I_DAC	-5 to +5 V
A13TP27/LO_NULL_Q_DAC	-5 to +5 V

The remaining biases are 2<sup>nd</sup> \_LO\_PIN and 2<sup>nd</sup> \_LO\_ATTEN. Since these are currents they cannot be directly measured at the Lowband assembly connector. The output of the DAC which controls this ALC circuit on A13 is A13TP25. To help verify that this part of the circuitry which drives the Lowband assembly is functioning correctly, perform the 2<sup>nd</sup> LO Power adjustment.

### A13 Front End Driver

The Front End Driver assembly contains the circuitry needed to drive the microcircuits and other assemblies used in the RF section. Many of these circuits can be verified using the previous discussions for verifying these assemblies. The voltage values on selected connectors are (with ground connection on A13TP16 top of board near fans):

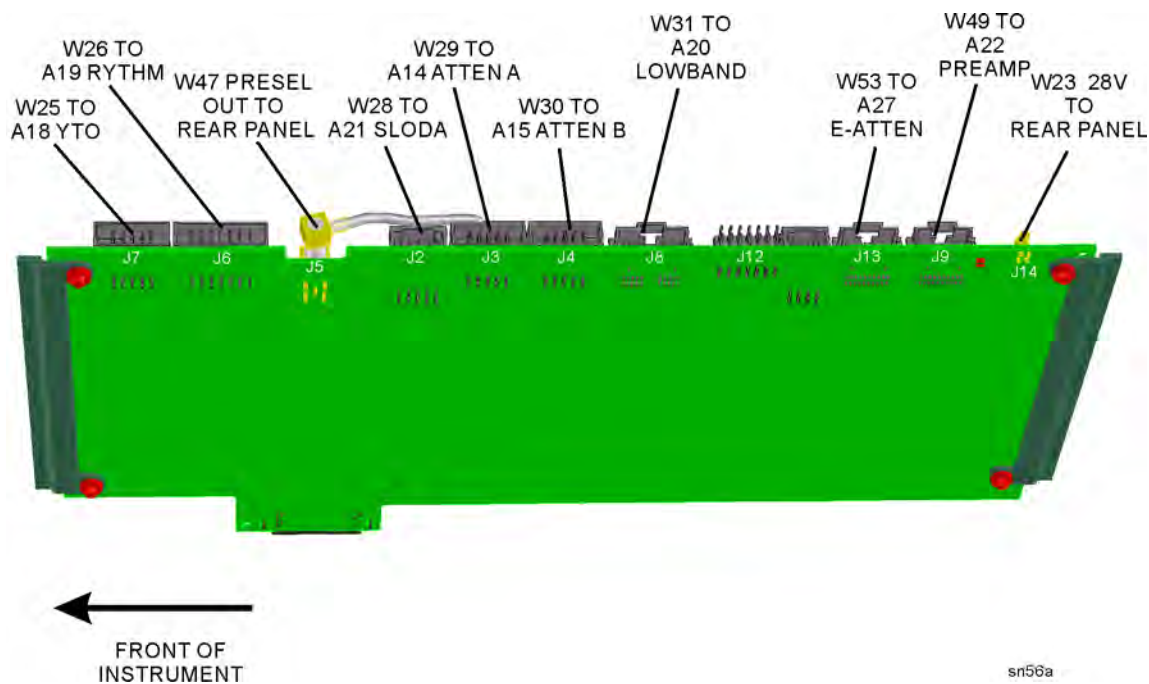


Option 219, Noise Figure, provides a switched 28V (via A13J14) to the rear panel to drive a noise source. Press **System, Service**, enter the password -49, and press **Service, Noise Source** to turn on the 28V at J14. This 28V is the result of regulating the +32V power supply voltage on the Front End Driver assembly. If the 28V cannot be turned on or is not  $28V \pm 0.2V$ , suspect the Front End Driver or a power supply problem. The RF input attenuator also uses the +32V supply, so if the attenuator also functions incorrectly, suspect an incorrect power supply level.

Option AYZ, External Mixing, requires the front end driver to switch the input signal path on the A10 3<sup>rd</sup> converter and provides the preselector tune out range to the rear panel. The preselector tune out is required to tune the tracking filter on the Agilent 11974 series preselected mixers.

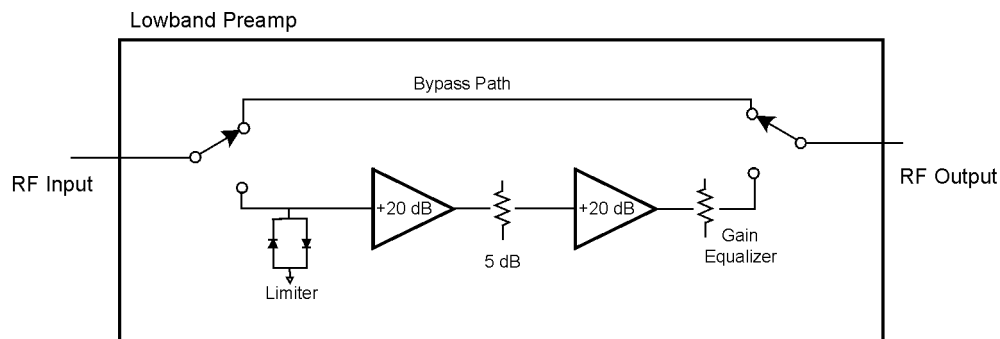
The LO leveling circuit and LO Unlock Sense circuits are on this assembly.

**Figure 3-8 Front End Driver Assembly - E4440A, E4443A, E4445A**



### A22 Low Band Preamp (Option 1DS)

**Figure 3-9** Preamp Block Diagram



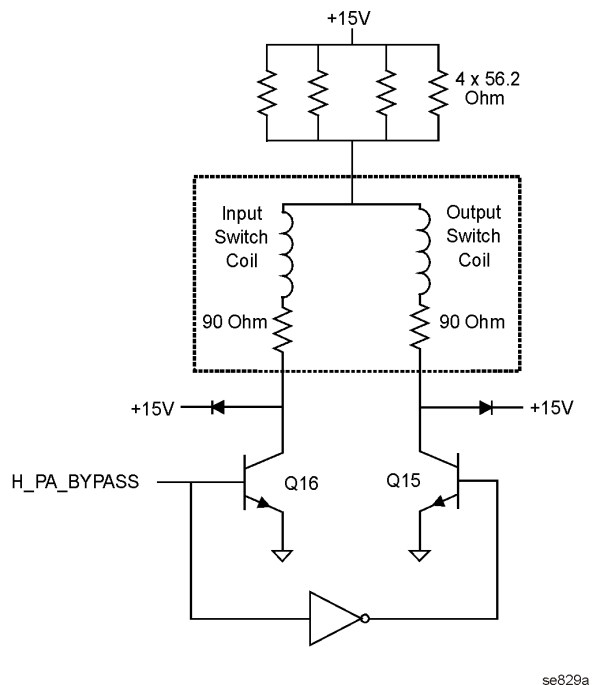
se828a

The Low Band Preamp has a nominal gain of 30 dB and contains two electro-mechanical coax switches. The frequency range of the preamp is 100 kHz to 3 GHz. The input signal level at the preamp should not exceed  $-30$  dBm. To verify its operation, display the  $-25$  dBm, 50 MHz calibrator signal on screen with a 5 MHz span and the input attenuator set to 10 dB. Select the Low Band Preamp path by pressing **AMPLITUDE, More, Int Preamp On**, (listen for a distinctive “click”) and measure the signal levels at the input and output with a spectrum analyzer. Also, the displayed signal on the PSA should not change position when the preamplifier is switched in and out, but the noise floor will decrease with the preamp on. Please note that the RF attenuator value may increase, depending on the reference level, causing the noise floor to increase.

The preamp is controlled by supply biases and coax switch voltages. A nominal +9 volts should be present at A13J9 pins 2 and 3. Switch voltages can be checked per the table (the ribbon cable must remain attached).

Node	Off Volts	On Volts
A13J9 pins 18,19 +COIL	13	13
A13J9 pin 20 SW1	0.3	13
A13J9 pin 17 SW2	13	0.3

**Figure 3-10 Coax Switch Bias Circuit**



### A27 Electronic Attenuator Description (Option B7J)

**Purpose:** The electronic attenuator facilitates the accurate, frequent, and rapid attenuation that is optimal for digitally modulated signals. The attenuator supplies 40 dB of attenuation in 1 dB steps.

The instrument must be in Basic mode to allow front panel control of the electronic attenuator. Press **MODE**, **Basic**, **Input/Output**, **Input Atten**. The electronic attenuator is actuated by the instrument firmware during comms measurements.

**Signal Path:** The low band signal is routed from the RYTHM. A switch in the electronic attenuator selects either the bypass path, or the attenuation path. The output signal is routed to the A20 Low Band assembly.

**Troubleshooting:** Select Spectrum Analysis mode. Apply a 50 MHz input signal to the analyzer and select zero span. Measure the signal on the W51 input cable after detaching it from the input connector. Reattach the input cable and measure the power out of the attenuator at J2. In Spectrum mode, the attenuator pads should be bypassed and the output power should be input power minus 0.2 to 0.3 dB.

Select Basic mode. Press **Input/Output** and select **Input Port Amptd Ref**. Set the analyzer center frequency to 50 MHz to display the internal calibration signal. Vary the input attenuation from 0 dB to 40 dB. The displayed amplitude should vary by less than 1 dB.

Troubleshooting the RF Section (E4440A, E4443A, E4445A)  
**RF Section Description (E4440A, E4443A, E4445A)**



---

**4 Troubleshooting the RF Section  
(E4446A, E4447A, E4448A)**

---

## What You Will Find in This Chapter

The following information is found in this chapter:

1. Theory of operation of the RF section for model numbers E4446A, E4447A, and E4448A.
2. Isolating the cause of an hardware problem by verifying the functionality of assemblies in the RF section signal path.
3. Block diagrams of the RF section of the analyzer.

---

**NOTE**

*Each section describes how the assembly works and gives information to help you troubleshoot the assembly. Each description covers the purpose of the assembly, describes the main components, and lists external connections to the assembly.*

---

This following descriptions are found in this chapter:

- RF Section Description (E4446A, E4447A, E4448A) .....page 91
- Overall Front End .....page 95
- A14 and A15 Step Attenuators .....page 96
- A21 FELOMA and A29 FELOMA/SBTX Driver .....page 98
- A19 SBTX/Rythm Assembly .....page 101
- A18 YTO .....page 103
- A20 Lowband .....page 104
- A13 Front End Driver .....page 107
- A22 Low Band Preamplifier (Option 1DS) .....page 108
- A27 Electronic Attenuator Description (Option B7J) .....page 109

---

## RF Section Description (E4446A, E4447A, E4448A)

### Purpose

The RF front end section converts input signals to a 3<sup>rd</sup> IF of 21.4 MHz. This section contains assemblies which generate Local Oscillator (LO) signals and assemblies which use the LO signals to mix the RF Input and the subsequent IF signals. Assemblies in the RF section also provide attenuation and circuit protection, gains and trigger signals, and a path for the 50 MHz calibrator signal.

### RF Block Diagram (E4448A Example)

---

#### NOTE

Refer to the E4446A/E4447A/E4448A Overall Block Diagram throughout this procedure. The block diagram outlines instrument settings and input power levels to obtain the measured levels in this procedure.

---

The 3 Hz to 50 GHz RF input signal first enters the input attenuators, A14 and A15. The input attenuators provide 0 to 70 dB attenuation in 2 dB steps. The A14 Attenuator contains a switch that allows the -25 dBm, 50 MHz calibrator signal to be switched into the signal path for amplitude calibration. The E4446A, E4447A, and E4448A do not have a DC blocking cap in the signal path. Therefore, the first mixer can easily be damaged if DC is present.

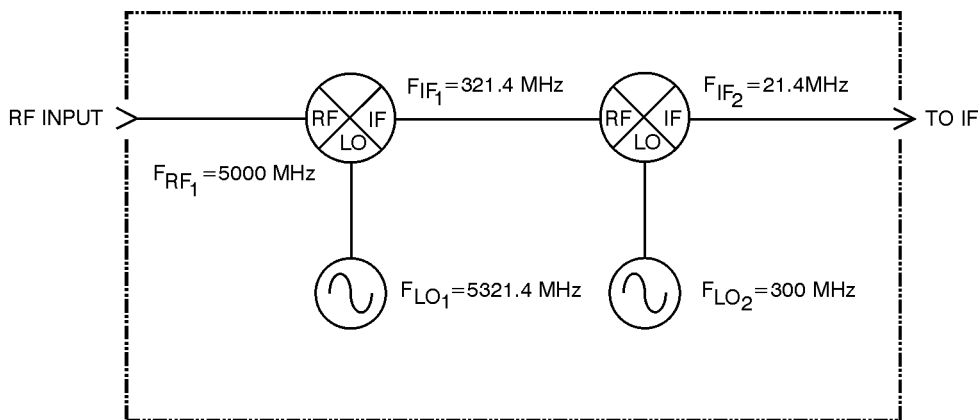
The attenuated input signal enters the A19 SBTX/RYTHM assembly, where a switch at the input of the SBTX (switched Barium-tuned filter/mixer) routes the signal through the SBTX or to the RYTHM assembly. Switches in the SBTX and RYTHM sub-assemblies route the input signal to one of three mixing paths:

- If the signal frequency is 26.8 GHz to 50 GHz, the signal goes through the tracking preselector and mixer in the SBTX where it is down-converted to 3.9214 GHz and sent to the A30 First IF Amplifier (FIFA). The output of the FIFA is connected through a 3.9214 GHz bandpass filter to the second mixer on the A20 Lowband assembly. The second mixer converts the signal to 321.4 MHz.
- If the signal frequency is 3 GHz to 26.8 GHz, the signal is routed through the 27 GHz low pass filter cable to the RYTHM (routing YIG-tuned harmonic mixer) where it passes through a YIG-tuned filter. The YIG-tuned filter tracks the displayed input signal as the instrument sweeps and removes spurious signals such as images and multiples. Next the signal is down-converted to the 321.4 MHz IF using the harmonically-pumped mixer. The IF signal is then sent to the A10 Third Converter.

- If the signal frequency is 3 Hz to 3 GHz, the SBTX switch routes the signal through the 27 GHz low pass filter cable, bypassing the tracking preselector and mixer. The 3 Hz to 3 GHz signal is applied to FL1, the 3 GHz lowpass filter. If the instrument contains Option 1DS (preamplifier) or Option B7J, (digital demod hardware), the signal also routes through them. The signal then enters the A20 Lowband assembly.

The A20 Lowband assembly contains both the first and second mixers. The first mixer up-converts the RF signal to the 3.9214 GHz first IF. The first IF signal leaves the Lowband assembly and routes through the switch on the A30 FIFA assembly and then on to FL2, the 3.9214 GHz bandpass filter, before returning to the Lowband assembly. The second mixer down-converts the first IF to the 321.4 MHz second IF. The second IF is applied as one of the inputs to the A10 Third Converter.

**Figure 4-1 Example of Down Conversion**

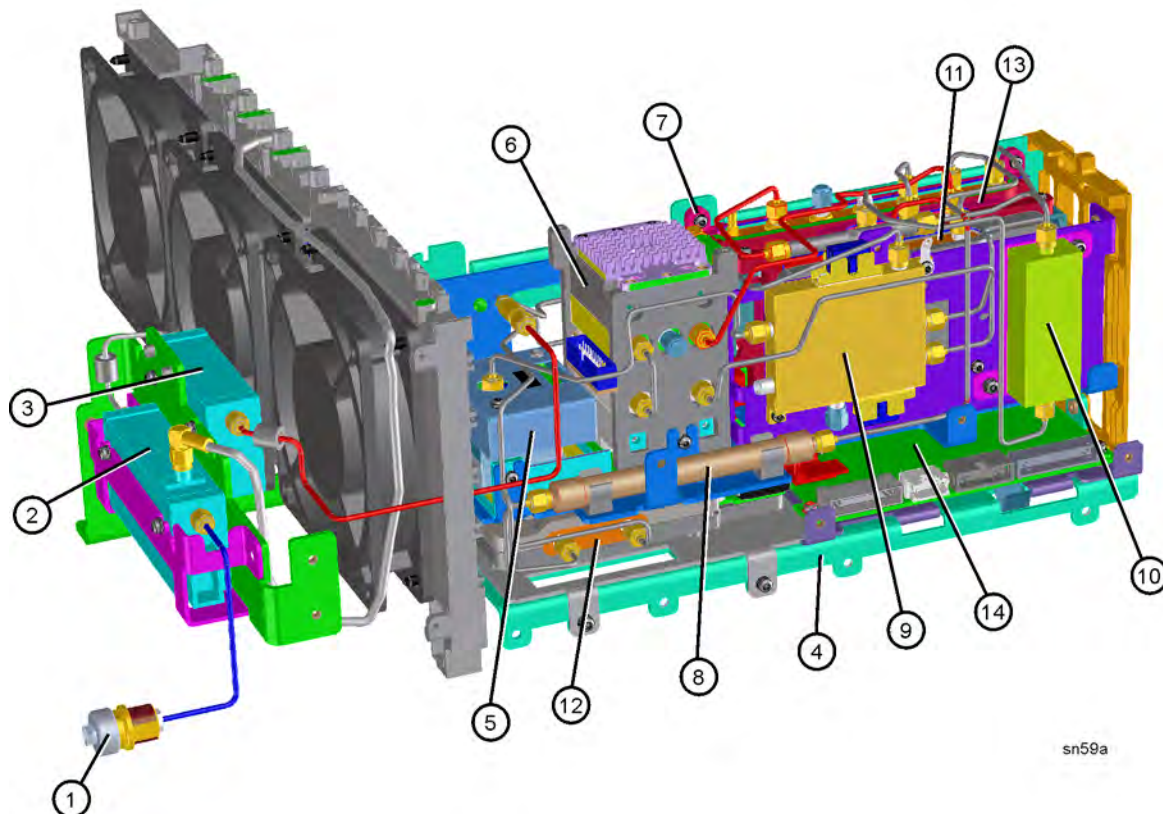


se861a

In the Third Converter, one of three possible 321.4 MHz IF signals is selected. The signal at J1 is from the “highband” or microwave port of the RYTHM converter. The signal at J2 is from the A20 Lowband assembly. This can be either the 3 Hz to 3 GHz “lowband” input signal that has been frequency shifted, or the 26.8 GHz to 50 GHz “millimeter band” input signal that has been pre-filtered and down-converted in the SBTX and then passed through the second converter. If Option AYZ is present, J3 is the 321.4 MHz IF input from the external mixer.

The 321.4 MHz signal is fed to the system variable gain circuit that is used to establish gain at 50 MHz as well as compensate for front end frequency response as the instrument tunes across its frequency range. The third converter down-converts the 321.4 MHz signal to 21.4 MHz.

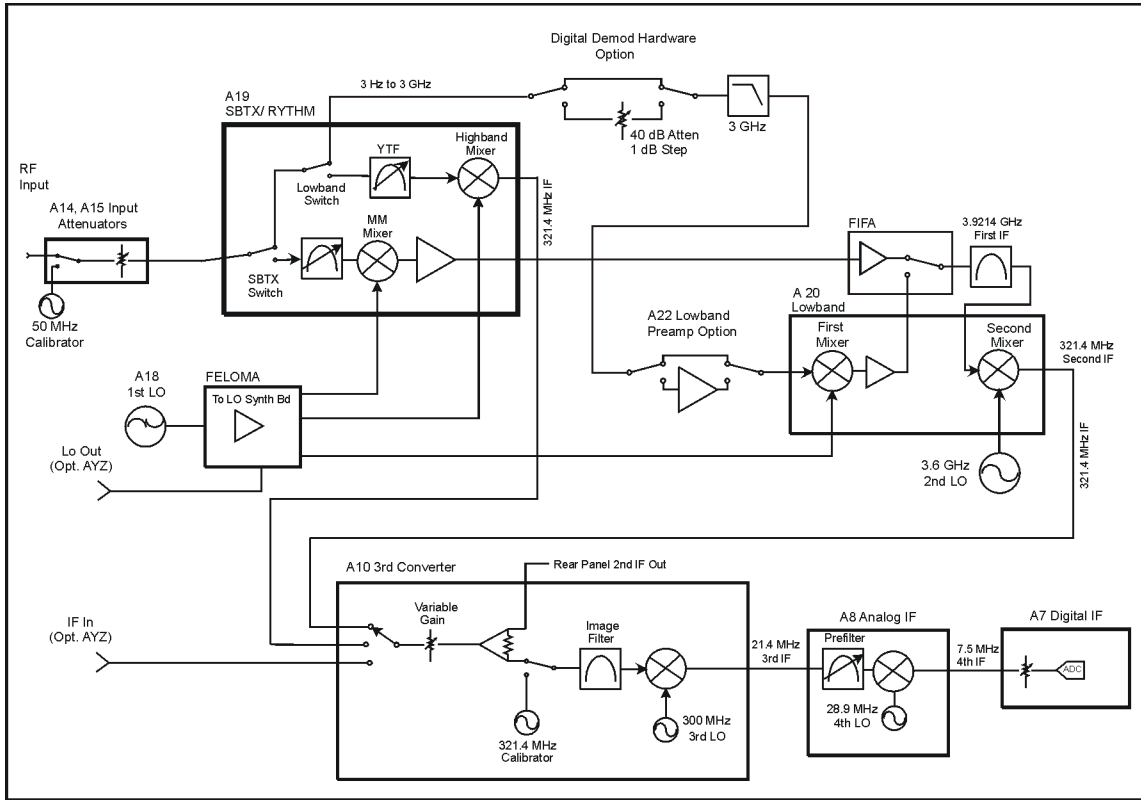
**Figure 4-2 RF Section Assemblies - E4446A, E4447A, E4448A**



sn59a

Item	Description
1	J1 Input Connector, 2.4 mm
2	A14 Input Attenuator (10 dB)/Switch
3	A15 Input Attenuator (60 dB)
4	L-bracket, RF Main
5	A18 YTO, 2.9 to 7 GHz (Yig Tuned Oscillator)
6	A19 SBTX/Rythm Assembly
7	A20 Low Band Assembly
8	FL1 Low Pass Filter, 3 GHz
9	A21 FELOMA (Frequency Extended LO Multiplying Amplifier)
10	FL2 Band Pass Filter, 3.9214 GHz
11	A22 Preamplifier Assembly (Option 1DS)
12	A27 Electronic Attenuator (Option B7J)
13	A30 FIFA, First IF Amplifier Assembly
14	A29 SBTX Driver Board

**Figure 4-3 Block Diagram with RF Options - E4446A, E4447A, E4448A**



sn512a

- Option B7J - Digital Demod Hardware. The electronic attenuator works over the lowband frequency range of 100 kHz to 3 GHz. In bypass mode, the coax switches in the electronic attenuator board route the RF signal on through to the Lowband board. The electronic attenuator path consists a 40 dB, 1 dB step solid state attenuator.
- Option 1DS - Low Band Preamp. In bypass mode, the coax switches route the Low Band RF signal on to the Lowband assembly. When in preamp mode the 30 dB gain, low noise figure amplifier path is selected.
- Option AYZ - External Mixing. Allows an external preselected or unpreselected mm wave mixer to be used with the instrument.

## RF Assembly Quick Check - E4446A, E4447A, E4448A

---

**NOTE**

---

To perform the following checks, it will be necessary to remove the outer case and the top brace. See [Chapter 11](#) for removal procedures.

Turn the instrument on and allow it to complete its internal calibration routines. This routine will generate error messages if the signal level is incorrect through the system. Inject the 50 MHz, -25 dBm calibrator signal to the RF Section by pressing **Input/Output, Input Port, Amptd Ref** (f = 50 MHz). Set the instrument to CF = 50 MHz, Span = 0 Hz, and the input attenuator to 10 dB.

Disconnect the cable with the “3” color band from the third converter 21.4 MHz output A10J5. Connect the RF Input of another spectrum analyzer to A10J5. A 21.4 MHz, -30 dBm signal should be present.

### Verifying a Faulty Front End Assembly E4446A, E4447A, E4448A

#### Overall Front End

Finding a fault in the RF front end is best done by breaking the path and monitoring the signal level and frequency with another spectrum analyzer. The signal levels and frequencies are noted on the overall block diagram foldout for given input conditions. In following the first LO, breaking the signal path between the A18 YTO and the A21 FELOMA, or at the Sampler Output of the FELOMA, will cause an unlock condition. This can be resolved by using a power splitter to keep the loop complete and yet facilitate measurement. In doing this, the measured signal level due to loss of the splitter must be taken into account.

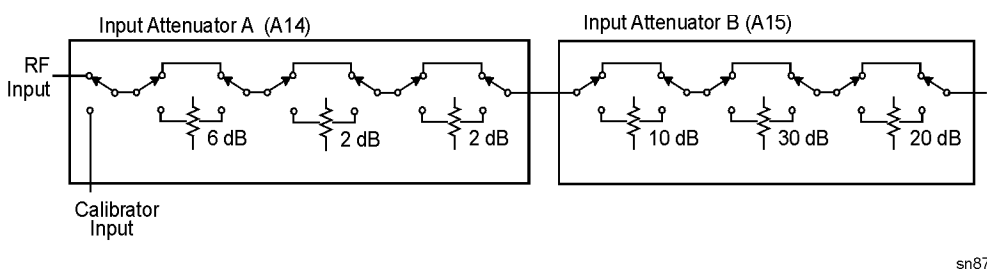
Since most RF section assemblies are expensive, a suspected faulty assembly should be verified by checking bias voltages and input signals before replacing them. This is best accomplished by improving accessibility of the test points and nodes on the A13 Front End assembly by using the extender boards and cables supplied in the Service Kit E4440-60090. For troubleshooting the RF Section, use the following pieces supplied in the kit:

A13 Front End Driver Extender	E4440-60049
A13J12 Bias Board	E4440-60041

### A14 and A15 Step Attenuators

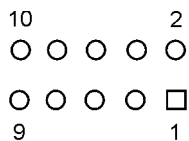
A faulty attenuator can cause improper signal level in both High and Low bands, often in certain combinations of attenuator settings. This can also prevent the 50 MHz calibrator signal from being displayed.

**Figure 4-4 Attenuator Block Diagram**



The attenuators receive control signals and supplies from the A13 Front End Driver assembly. A14 is fed from A13J3 and A15 is fed from A13J4. Ground is on pin 3 and the 25V supply is on pin 10. Viewing from the circuit side of the board, the connector pinouts are shown:

**Figure 4-5 Connector Pinout**



If the 50 MHz calibrator signal is not displayed, first verify its presence at A14J2. Disconnect the gray W20 cable from the attenuator and monitor the signal coming out of the cable with another spectrum analyzer. The signal should be 50 MHz at -25 dBm. Verify that the attenuator is receiving the proper TTL signals monitoring the points on A13J3 with a scope using the truth table.

Input Path	Calibrator Path Select J3 pin 2	RF Path Select
RF	High	Low
Calibrator	Low	High



Improper displayed signal amplitudes in some attenuator settings can be isolated to either A13 or A14 based on which steps are incorrect. Signal out of the attenuators can be measured by disconnecting the appropriate semirigid cable and using a spectrum analyzer. Referring to [Figure 4-4](#), A14 has two 2 dB sections and one 6dB section. A15 has a 10 dB, a 20 dB and a 30 dB section. Verify that the attenuators are receiving the correct switching sequences by using the following tables.

**Table 4-1 A15 Settings**

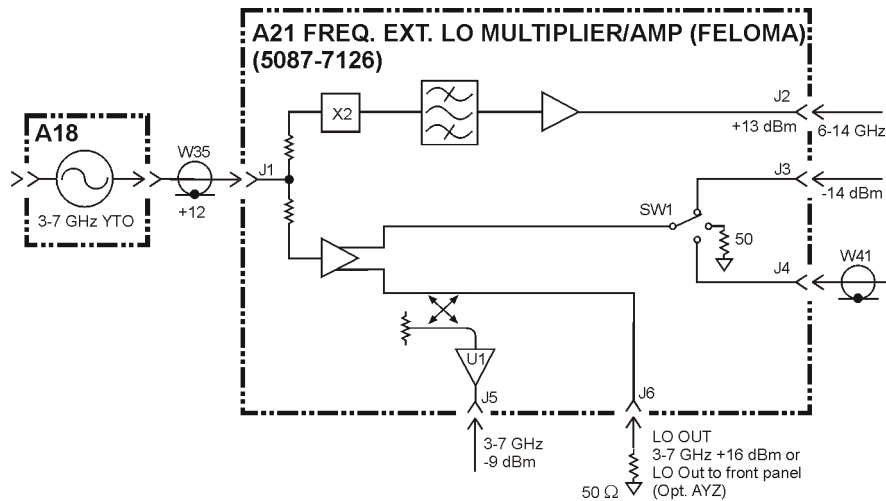
Attenuation (dB)	30 dB Select J4 pin 9	30 dB Bypass J4 pin 4	10 dB Select J4 pin 2	10 dB Bypass J4 pin 1	20 dB Select J4 pin 8	20 dB Bypass J4 pin 5
0	High	Low	High	Low	High	Low
10	High	Low	Low	High	High	Low
20	High	Low	High	Low	Low	High
30	Low	High	High	Low	High	Low
40	Low	High	Low	High	High	Low
50	Low	High	High	Low	Low	High
60	Low	High	Low	High	Low	High
70	Low	High	Low	High	Low	High

**Table 4-2 A14 Settings**

Attenuation (dB)	2 dB - B Select J3 pin 9	2 dB - B Bypass J3 pin 4	2 dB - A Select J3 pin 8	2 dB - A Bypass J3 pin 5	6 dB Select J3 pin 7	6 dB Bypass J3 pin 6
0	High	Low	High	Low	High	Low
2	High	Low	Low	High	High	Low
4	Low	High	Low	High	High	Low
6	High	Low	High	Low	Low	High
8	High	Low	Low	High	Low	High
10	High	Low	High	Low	High	Low

## A21 FELOMA and A29 FELOMA/SBTX Driver

Figure 4-6 FELOMA Block Diagram



sn510a

The A21 FELOMA (Frequency Extended LO Multiplier-Amplifier) provides amplitude leveling and distribution of the LO signal from the A18 YTO assembly. For frequency bands 0, 1, 2, 3 and 4, the 3 to 7 GHz LO is distributed to the Lowband or the RYTHM, to the 1<sup>st</sup> LO Out port, and to the A12 LO Synthesizer assembly. In frequency bands 5 and 6, the LO frequency is doubled and filtered before being sent to the SBTX.

The amplitude leveling of the 3 to 7 GHz LO signal inside FELOMA, biasing, and LO port switching is controlled by the A29 SBTX driver assembly.

Some common failure symptoms of a faulty FELOMA or the SBTX driver includes YTO unlocks, increased residual responses, LO unlevelled errors, and low signal amplitude in one or more frequency bands. The troubleshooting process below will help you determine which of the two assemblies is faulty.

### Verifying the A21 FELOMA Assembly

First check that the YTO signal is present at the LO IN connector by measuring the power at the cable from the YTO. The signal should be 3-7 GHz at +12 to +17 dBm.

Next verify the signals at the LO outputs. The Lowband, RYTHM, LO Out and Sampler outputs all range from 3 GHz to 7 GHz. The SBTX output is doubled, and will range from 6 to 14 GHz.

Table 4-3 lists the LO power at the different FELOMA output ports.

To verify the SBTX output at J2, set the PSA to a center frequency above 26.8 GHz and set the span to zero Hz.

Verify the RYTHM output at J3 by setting the center frequency of the PSA from 3 GHz to 26.5 GHz while in zero span. Notice the table includes some approximate out of band measurements, shown in italics, that can be useful if you suspect a port-to-port isolation problem.

Verify the Lowband output at J4 by setting the center frequency of the PSA from 3 Hz to 2.85 GHz while in zero span. Again, additional out of band values are given for isolation purposes.

Verify the Sampler output and the 1ST LO outputs while in zero span. Currently the J6 LO Output is not leveled.

**Table 4-3 Example measurements for FELOMA outputs**

<b>PSA Center Frequency</b>	<b>J2 SBTX Power/Freq</b>	<b>J3 RYTHM Power/Freq</b>	<b>J4 Lowband Power/Freq</b>	<b>J5 Sampler Power/Freq</b>	<b>J6 1<sup>st</sup> LO Out Power/Freq</b>
50 MHz	NA	<i>-21 dBm 3.971 GHz (typical)</i>	<b>+14 dBm 3.9714 GHz</b>	<b>-14 dBm 3.971 GHz</b>	<b>+14 dBm 3.971 GHz</b>
10 GHz	NA	<b>+13 dBm 5.161 GHz</b>	<i>-25 dBm 5.161 GHz (typical)</i>	<b>-9 dBm 5.161 GHz</b>	<b>+13 dBm 5.161 GHz</b>
30 GHz	<b>+13 dBm 13.040 GHz</b>	<i>-14 dBm 6.519 GHz (typical)</i>	<i>-17 dBm 6.519 GHz (typical)</i>	<b>-11 dBm 6.519 GHz</b>	<b>+15.95 dBm 6.519 GHz</b>

### Verifying the A29 SBTX/FELOMA Driver Assembly

Test points are provided on the A29 SBTX/FELOMA Driver board that allow you to confirm the DC drive levels to the FELOMA assembly are correct. There is a label on the FELOMA assembly that lists the target voltages in milli-volts. Access to the test points is gained by sliding the A29 assembly out of the instrument slightly.

1. Power down the instrument to avoid shorting out the A29 assembly while it is being unseated from the RF chassis.
2. Pull up on the stainless steel spring clip near the center of the assembly, and pull forward on the A29 bracket to slide the assembly 1 to 2 inches out of the instrument.
3. Locate test point 2 near the back of the board, and connect the DVM ground lead to TP2.
4. Connect the other DVM test lead to one of the test points listed in [Table 4-4](#).
5. Assure the A29 assembly is supported well and cannot short out against anything.
6. Turn on the instrument and set it to zero span and set the center frequency to correspond to the test point chosen in [Table 4-4](#).
7. Compare the DVM reading to the value documented on the FELOMA label. The values should match  $\pm 0.005$  volts, except for the Int B5 and Int B6 values that must be less than  $-275$  mv, but are usually close to the  $-350$  mv label.

**Table 4-4                    A29 SBTX Driver Board DC Levels To Be Compared With FELOMA Label**

<b>PSA Center Frequency</b>	<b>TP5 VG1 (mv)</b>	<b>TP12 VG2 (mv)</b>	<b>TP9 LO Level (mv)</b>	<b>TP4 SBTX Unleveled (mv)</b>	<b>TP11 "S" Sampler Unleveled (mv)</b>
50 MHz	VG1	VG2	Band0	NA	S
4 GHz	VG1	VG2	Band1	NA	S
10 GHz	VG1	VG2	Band2	NA	S
20 GHz	VG1	VG2	Band3/4	NA	S
30 GHz	NA	NA	IntB5	SBTX B5	S
50 GHz	NA	NA	IntB5	SBTX B6	S
External Mixing Frequency	NA	NA	"F" Label Value	NA	NA

### A19 SBTX/RYTHM Assembly

The A19 assembly is comprised of the SBTX (switched barium-ferrite tuned filter/mixer), and the RYTHM (routing yig-tuned harmonic mixer). The SBTX and the RYTHM are not separately replaceable. The SBTX provides a switch that routes the input signal to the RYTHM (high band and low band signals) or through the SBTX preselector and mixer (mm band path). The following table lists the frequencies where the switch points occur.

Center Frequency (Instrument in zero span)	Signal Routed to First Mixer on:
3 Hz to 3 GHz	Low band (through SBTX and RYTHM switches)
3.05 GHz to 26.8 GHz	RYTHM
> 26.8 GHz	SBTX

The RYTHM bands are bands 1 through 4 whose start (minimum) and stop (maximum) frequencies are shown in the following table:

Band	Minimum Frequency	Maximum Frequency
1	2.85 GHz	6.6 GHz
2	6.2 GHz	13.2 GHz
3	12.8 GHz	19.2 GHz
4	18.7 GHz	26.5 GHz

The mixing equations are:

$$\text{Band 1} \quad F_{LO} = F_{RF} + F_{IF}$$

$$\text{Band 2} \quad F_{LO} = (F_{RF} + F_{IF})/2$$

$$\text{Band 3, 4} \quad F_{LO} = (F_{RF} + F_{IF})/4$$

$$F_{IF} = 321.4 \text{ MHz}$$

The SBTX bands are bands 5 and 6 whose start (minimum) and stop (maximum) frequencies are shown in the following table:

Band	Minimum Frequency	Maximum Frequency
5	26.4 GHz	31.5 GHz
6	31.0 GHz	50 GHz

The mixing equations are:

$$\text{Band 5} \quad F_{LO} = (F_{RF} - F_{IF})/4$$

$$\text{Band 6} \quad F_{LO} = (F_{RF} + F_{IF})/8$$

$$F_{IF} = 3.9214 \text{ GHz}$$

Common failures with SBTX/Rythm are a damaged input switch due to input overstress, and a faulty preselector. The former can cause signal loss in any one of the three signal paths, or in all signal paths. The latter will cause signal loss or flatness problems in high band or the mm bands above 26.8 GHz.

Troubleshooting involves measuring the signal outputs of the A19 SBTX/Rythm assembly on another spectrum analyzer and monitoring the DC switching voltages on the A29 SBTX/FELOMA Driver assembly. Since the A13 Front End Driver assembly controls the SBTX driver assembly, also verify the A13 assembly is not the cause of the problem.

### Signal Path Troubleshooting

Refer to the E4446A/E4447A/E4448A overall block diagram in [Chapter 9](#). The block diagram outlines instrument settings and input power levels to obtain the measured levels documented in the block diagram.

1. Determine which frequency band or bands are faulty. Do this by connecting the PSA to a signal source and viewing 50 MHz, 5 GHz, and 30 GHz signals.

---

#### NOTE

When setting up the PSA to view any signals above 3 GHz, you must press the **Preselector Center** key (found under the **Amplitude** key) to assure the preselector is properly centered. The **Preselector Adjust** key allows you to manually adjust the preselector, and sometimes a misadjusted preselector can cause 40 to 50 dB of signal loss.

---

2. If the problem is in high band or mm band, set the PSA for a start frequency of 3 GHz and stop frequency of 30 GHz. Verify the presence of a sweep ramp on the rear panel PRE-SEL TUNE OUT connector. The oscilloscope display should indicate a series of ramps and steps ranging from approximately 0 to 5 V. This tune ramp originates on the A13 Front End Driver assembly and is used to tune the preselectors in the SBTX/RYTHM assembly.
3. Set the PSA to zero span and use a low loss cable between the measuring spectrum analyzer and the assembly under test. Set up the PSA and the signal source as instructed in the block diagram note (analyzer in zero span, and analyzer and source set to one of several frequencies that correspond to the different signal paths). Measure the signal level at the appropriate output port of the SBTX/RYTHM or cable. Measure the LO input signals at the output ports of A21 FELOMA.
4. The SBTX and RYTHM must be replaced as an entire unit. It is possible to remove the A19FL1 cable and confirm a faulty RYTHM or the SBTX switch. The A19FL1 cable is not separately replaceable.

### SBTX Control Verification

Refer to the A29 FELOMA/SBTX driver troubleshooting information on [page 100](#). Verify that Test Point 4 and Test Point 9 voltages are correct.

### A18 YTO

The YTO (YIG-Tuned Oscillator) supplies the raw 3 to 7 GHz LO signal. Verify that its output is from +12 dBm to +17 dBm. With a DVM, verify the presence of the supplies on the A13 Front End Driver:

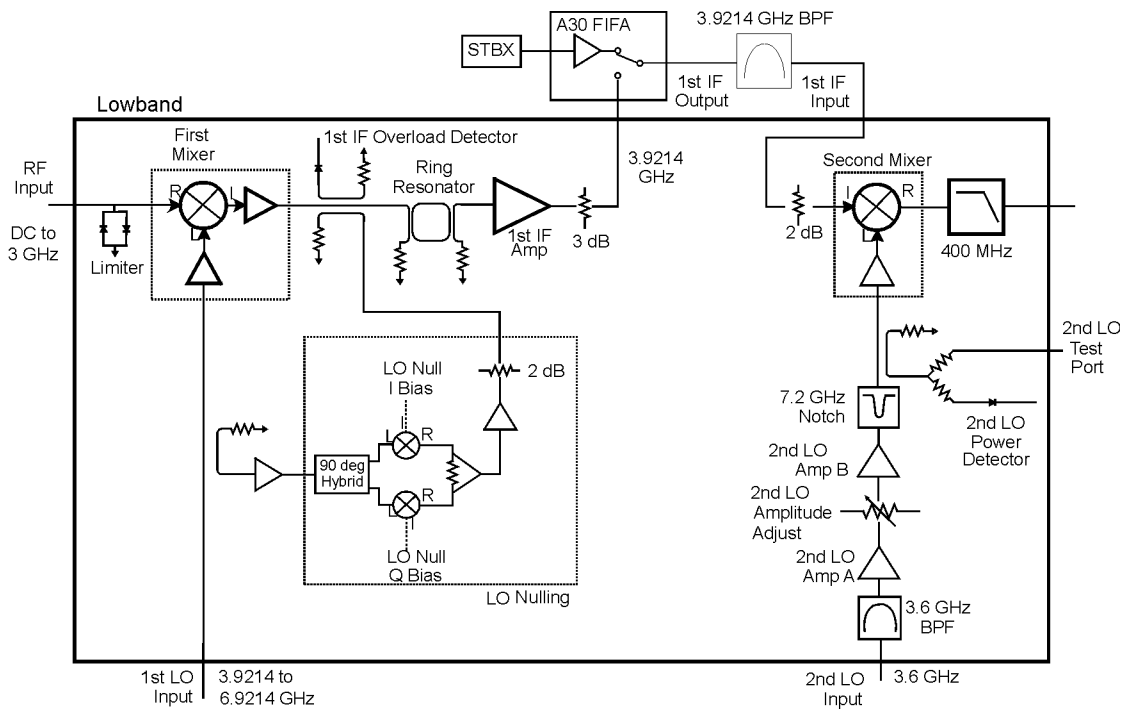
<b>J7 Pin 4</b>	<b>J7 Pin 5</b>	<b>J7 Pin 7</b>	<b>J7 Pin 9</b>
+15 V	-5 V	+15 V	+15 V

Common symptoms of a faulty YTO are YTO Unlock errors, spurious signals, and low signal level at all frequencies. Two current-driven coils are used to tune the YTO. Both coils are used in all spans. The coil drivers are on the A12 LO Synthesizer assembly and the signals route through the A13 Front End Driver.

### A20 Lowband

The Lowband assembly is the front end converter for frequencies below 3 GHz and the 2<sup>nd</sup> converter for input frequencies 26.8 GHz to 50 GHz. The Lowband assembly encompasses both the first and second mixers, the 2<sup>nd</sup> LO amplifiers, LO Nulling and filtering.

**Figure 4-7 Lowband Assembly Block Diagram**



sn58a

Mixing equation:  $F_{LO} = F_{RF} + F_{IF}$   
 $F_{IF} = 3.9214 \text{ GHz}$



The 3 Hz to 3 GHz RF input signal enters the Lowband assembly at A20J1. The first component in the RF path is the RF Limiter. This limiter prevents excessive RF energy from damaging the first mixer when the input attenuator is set to zero dB. The first mixer up-converts the 3 Hz to 3 GHz signal to the 3.9214 GHz first IF. The first LO, which enters the Lowband assembly from the FELOMA, ranges from 3.9214 to 6.9214 GHz. Following the first mixer is a coupler that routes a portion of the input signal to the first IF overload detector. The first IF signal leaves the Lowband assembly, routes through the switch in the First IF Amplifier (FIFA) and the external first IF bandpass filter, then re-enters the Lowband assembly in the Second Converter section. The second mixer down-converts the 3.9214 GHz first IF to the 321.4 MHz second IF. The second LO is at 3.6 GHz.

LO Nulling is the process of reducing the LO feedthrough signal that appears on screen when the instrument is tuned to 0 Hz. The on-screen LO feedthrough amplitude is typically reduced 30 dB. The LO null function can be turned on and off using a switch in the service menu. With LO nulling applied, the LO's phase noise contribution to the analyzer's noise floor is reduced thereby increasing dynamic range. This is important when measuring signals close to 0 Hz.

A faulty Lowband assembly will commonly cause low or no signal below 3 GHz, and no LO Nulling. The 3.6 GHz second LO signal is supplied by the A9 Second LO assembly. The second LO is amplified in the Lowband assembly before it is applied to the Second Mixer

A failure with the Lowband assembly will likely result in a problem with signals up to 3 GHz and above 26.8 GHz. Start troubleshooting in lowband with a 50 MHz input signal. First check for a signal at the input, A20J1, the First LO at A20J2, and the 2<sup>nd</sup> LO at A20J5 by referring to the signal conditions given on the overall block diagram. The 2<sup>nd</sup> LO signal can be checked at A20J6. Similarly the first IF signal can be verified at A20J3.

With the PSA set to a center frequency below 3 GHz, and in zero span, check that the bias voltages are present. Some of these can be accessed on the A13J12 Test Connector and some others have test points. With the negative lead of the DVM on A13J12 pin 6, look for values listed in the table.

---

**CAUTION**

---

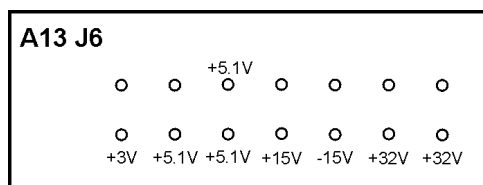
Use care when probing connector pins on A13, especially on A13J8. Connector spacings are close and shorting nodes can cause damage.

Pin/ Name	Nominal Voltage
A13J12 pin1/-5V_F	-5 V
A13J12 pin2/-5V_M1LO	-5 V
A13J12 pin3/-5V_M1IF	-5 V
A13J12 pin4/-5V_M2LO	-5 V
A13J8 pins 7,8/+3V_LB	3 V
A13J8 pin25/+5.2V_LB	5.2 V
A13J8 pin16/+10V_LB	10 V
A13TP22/M1LO_ADJ	100 mV
A13TP23/M1IF_ADJ	150 mV
A13TP24/M2LO_ADJ	100 mV
A13TP26/LO_NULL_I_DAC	-5 to +5 V
A13TP27/LO_NULL_Q_DAC	-5 to +5 V

The remaining biases are 2<sup>nd</sup> \_LO\_PIN and 2<sup>nd</sup> \_LO\_ATTEN. Since these are currents they cannot be directly measured at the Lowband assembly connector. The output of the DAC which controls this ALC circuit on A13 is A13TP25. To help verify that this part of the circuitry which drives the Lowband assembly is functioning correctly, perform the 2<sup>nd</sup> LO Power adjustment.

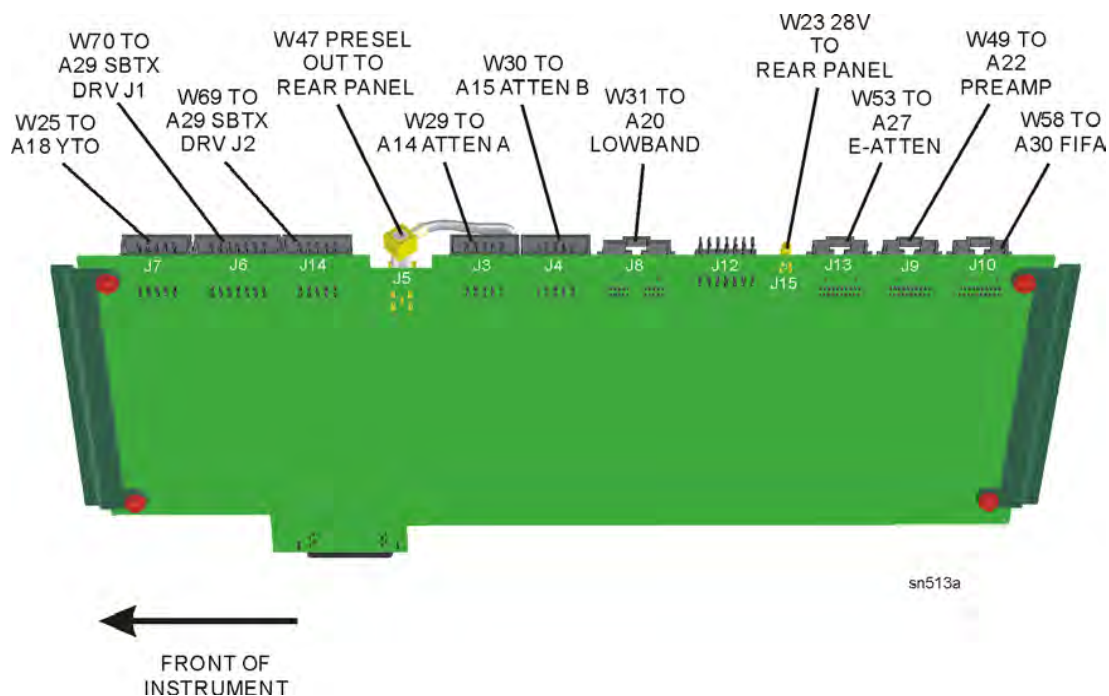
### A13 Front End Driver

The Front End Driver assembly contains the circuitry needed to drive the microcircuits and other assemblies used in the RF section. Many of these circuits can be verified using the previous discussions for verifying these assemblies. The voltage values on selected connectors are (with ground connection on A13TP16 top of board near fans):



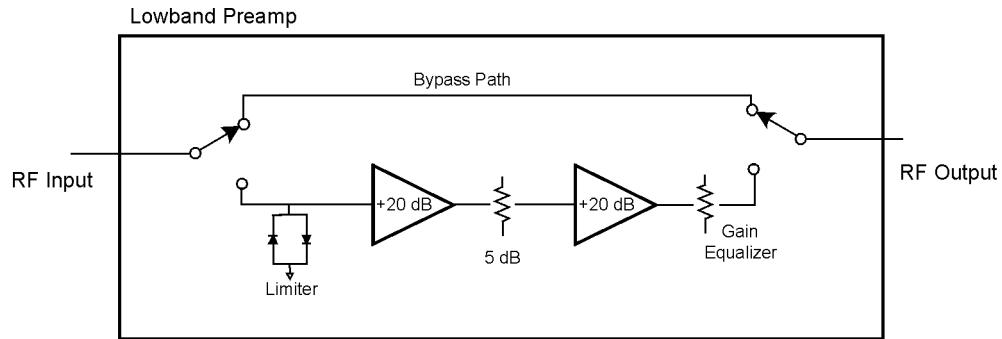
Option 219, Noise Figure, provides a switched 28V (via A13J15) to the rear panel to drive a noise source. Press System, Service, enter the password -49, and press **Service, Noise Source** to turn on the 28V at J15. This 28V is the result of regulating the +32V power supply voltage on the Front End Driver assembly. If the 28V cannot be turned on or is not  $28V \pm 0.2V$ , suspect the Front End Driver or a power supply problem. The RF input attenuator also uses the +32V supply, so if the attenuator also functions incorrectly, suspect an incorrect power supply level.

**Figure 4-8 Front End Driver Assembly - E4446A, E4447A, E4448A**



### A22 Low Band Preamp (Option 1DS)

**Figure 4-9** Preamp Block Diagram



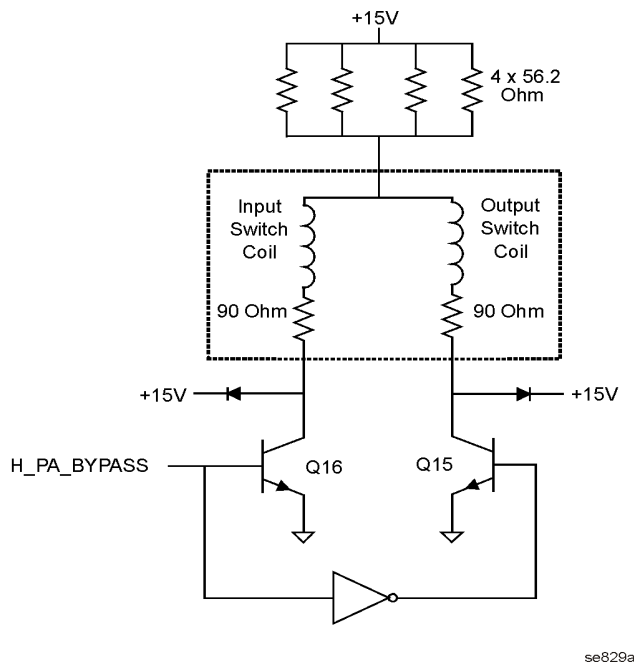
se828a

The Low Band Preamp has a nominal gain of 30 dB and contains two electro-mechanical coax switches. The frequency range of the preamp is 100 kHz to 3 GHz. The input signal level at the preamp should not exceed  $-30$  dBm. To verify its operation, display the  $-25$  dBm, 50 MHz calibrator signal on screen with a 5 MHz span and the input attenuator set to 10 dB. Select the Low Band Preamp path by pressing **AMPLITUDE, More, Int Preamp On**, (listen for a distinctive “click”) and measure the signal levels at the input and output with a spectrum analyzer. Also, the displayed signal on the PSA should not change position when the preamplifier is switched in and out, but the noise floor will decrease with the preamp on. Please note that the RF attenuator value may increase, depending on the reference level, causing the noise floor to increase.

The preamp is controlled by supply biases and coax switch voltages. A nominal +9 volts should be present at A13J9 pins 2 and 3. Switch voltages can be checked per the table (the ribbon cable must remain attached).

Node	Off Volts	On Volts
A13J9 pins 18,19 +COIL	13	13
A13J9 pin 20 SW1	0.3	13
A13J9 pin 17 SW2	13	0.3

**Figure 4-10 Coax Switch Bias Circuit**



### A27 Electronic Attenuator Description (Option B7J)

**Purpose:** The electronic attenuator facilitates the accurate, frequent, and rapid attenuation that is optimal for digitally modulated signals. The attenuator supplies 40 dB of attenuation in 1 dB steps.

The instrument must be in Basic mode to allow front panel control of the electronic attenuator. Press **MODE**, **Basic**, **Input/Output**, **Input Atten**. The electronic attenuator is actuated by the instrument firmware during comms measurements.

**Signal Path:** The low band signal is routed from the RYTHM. A switch in the electronic attenuator selects either the bypass path, or the attenuation path. The output signal is routed to the A20 Low Band assembly.

**Troubleshooting:** Select Spectrum Analysis mode. Apply a 50 MHz input signal to the analyzer and select zero span. Measure the signal on the W51 input cable after detaching it from the input connector. Reattach the input cable and measure the power out of the attenuator at J2. In Spectrum mode, the attenuator pads should be bypassed and the output power should be input power minus 0.2 to 0.3 dB.

Select Basic mode. Press **Input/Output** and select **Input Port Amptd Ref**. Set the analyzer center frequency to 50 MHz to display the internal calibration signal. Vary the input attenuation from 0 dB to 40 dB. The displayed amplitude should vary by less than 1 dB.

Troubleshooting the RF Section (E4446A, E4447A, E4448A)  
**RF Section Description (E4446A, E4447A, E4448A)**

---

---

**5      Troubleshooting the Synthesizer  
Section**

## What You Will Find in This Chapter

---

**NOTE**

*The synthesizer section covers the synthesizer assembly, the reference assembly, and the second LO/fan control assembly.*

---

The following information is found in this chapter:

1. Theory of operation for the reference, synthesizer, and 2nd LO sections at the assembly level.
2. Interconnections between assemblies.
3. Isolating the cause of a hardware problem by verifying the assembly functionality.

**NOTE**

*Each section first describes how the assembly works, then gives information to help you troubleshoot the assembly. Each description explains the purpose of the assembly, describes the main components, and lists external connections to the assembly.*

---

### **Important!**

The Align All Now routine sets the signal levels on several assemblies. The routine will run automatically if Auto Align is set to On. When troubleshooting, it is recommended that Auto Align be set to Off to give you total control of the instrument. To set Auto Align to Off, press **System, Alignments, Auto Align Off**.

You may want to trigger an alignment from time to time, especially when you replace assemblies. To run Align All Now, press **System, Alignments, Align All Now**.



## A12 Synthesizer Assembly Description

**Purpose.** The A12 synthesizer assembly phase locks the A18 YTO, resulting in a very stable, low phase noise LO signal. The A12 synthesizer assembly consists of sub-assemblies A12A1 LO/Synthesizer board and the A12A2 sample oscillator. It is possible to replace each sub-assembly, or the entire A12 synthesizer.

## Verifying the A12 Synthesizer Board

### Troubleshooting LO and Sampling Oscillator Unlock Conditions:

#### Error messages

Sampling Oscillator Unlock, Failure acquiring SO frequency lock

This message appears when the 600 MHz signal to the A12A2 is not present. Check the MMCX cable connections on A12W2 between the A12A2 and A12A1 boards.

1st LO unlock, failure acquiring FracN frequency lock

This message will also appear when the 1st LO is unlocked for many reasons. It will often appear whenever the sampling oscillator unlock message is displayed.

---

**NOTE**

Perform the Auto Align All routine before beginning troubleshooting. The LO power is adjusted during this internal alignment process.

---

#### Input signal check

Measure the sampler output from the A21 LO distribution amplifier. Since removing the LO signal will cause a 1st LO unlock and an unstable measurement, you must inject a signal into the LO amplifier and measure the signal at the sampler output port.

---

**NOTE**

Please use care when moving the semi rigid cables since they can crack or break, especially at the connector solder joints. The almost invisible cracks can cause residual responses to appear.

---

Power down the PSA.

Disconnect W35, the semi-rigid cable from the LO IN port of the A21 LO distribution amplifier.

Connect a cable with SMA connectors to a source capable of 4 GHz and +10 dBm output power. Measure the power level at the end of the cable with a power meter to assure the proper level.

Disconnect the power sensor, and connect the cable to the LO IN port of A21.

Disconnect the semi-rigid Sampler In cable W24 from J1 of the A12 synthesizer. Connect a spectrum analyzer to the end of this cable.

Power on the PSA and immediately measure the Sampler out signal amplitude on the spectrum analyzer. The signal should be 4 GHz at 0 dBm. If the PSA's internal auto align runs, the measured signal will change to about -13 dBm. Therefore, perform the measurement during the boot process.

Extend the A12 synthesizer using the E4440-60049 extender board. You will need to install the special offset board guides so the extender card will fit into the motherboard connector with out bending the extender board. Also, connect an extender SMA cable between the sampler in cable W24 and J1.

Measure the 600 MHz input by connecting the spectrum analyzer and SMA cable to the extender board jack P2. Set the extender board switch in the lower position. The signal should measure 600 MHz at -5 dBm.

Measure the 10 MHz input signal by connecting the spectrum analyzer to P3 on the extender board. The 10 MHz signal should measure +2 dBm.

#### **Determining which of the two sub assemblies is faulty**

The PSA has two major phase lock modes, dual loop mode is used in frequency spans  $< 2$  MHz and single loop mode is used for frequency spans  $\geq 2$  MHz. These frequency breaks occur when the phase noise optimization under the auto couple menu is set to auto. Troubleshooting is performed by placing the PSA in each of the modes to determine where the unlock condition occurs.

### Dual Loop troubleshooting

If an LO unlock problem occurs only in dual loop mode (span < 2 MHz) the cause is either the A12A2 Sampling Oscillator board or the sampler circuit on the A12A1. The A12A2 board is only used in dual loop mode. To verify the problem is the A12A2 you must measure the sampling oscillator output at A12A2 J1. The following table lists PSA center frequency verses sample oscillator frequency at J1. J1 is a female MMCX connector. Use the MMCX to SMB cable supplied in the service kit. The three frequencies test the low, middle and high frequency range of the sample oscillator. If the frequencies are correct, yet the unlock appears, suspect the A12A1 synthesizer board. If the frequencies are incorrect or there is no output signal, suspect A12A2.

PSA settings: Span 100 kHz

Measuring Spectrum Analyzer: Span 20 kHz

PSA Center Frequency (MHz)	Sampling Oscillator Output (MHz)	Power Level
636	642.187	+12 dBm
228	700.781	+12 dBm
508	747.656	+12 dBm

### Single loop troubleshooting

When single loop mode (span  $\geq$  2 MHz) is bad, it will appear that dual loop is also bad, suspect the A12A1 board.

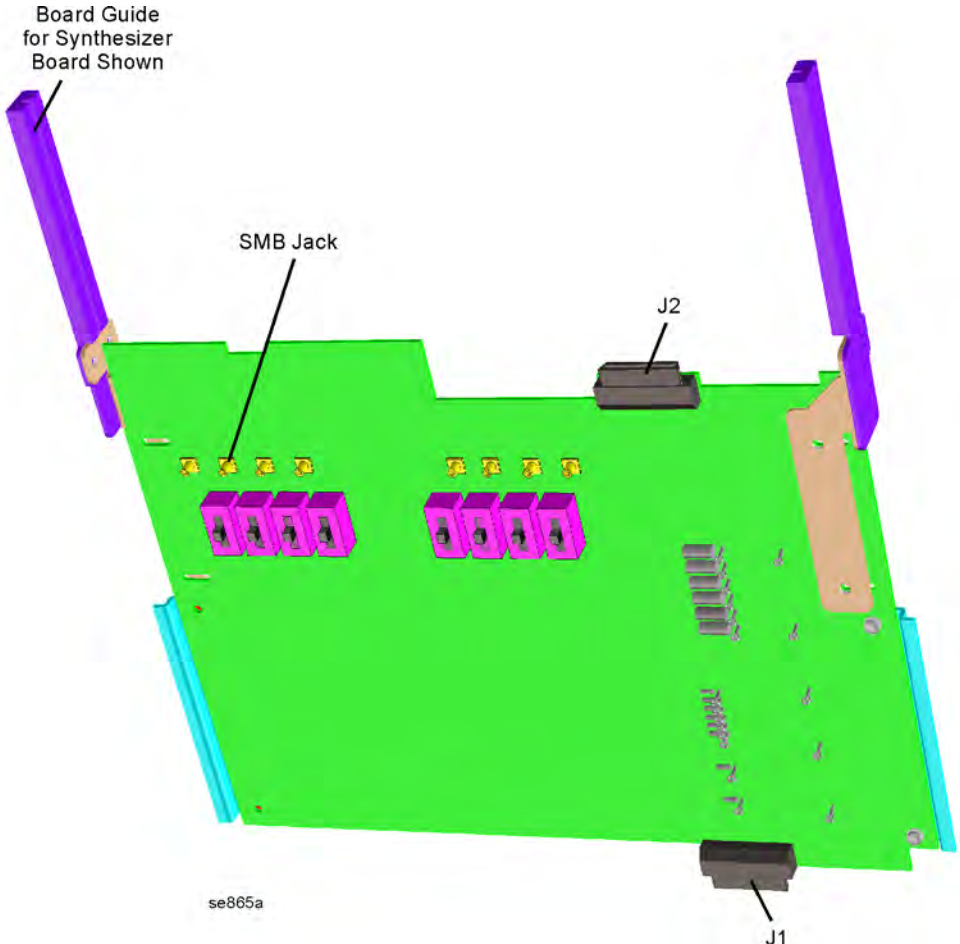
### E4440-60049 Extender Board

The E4440-60049 extender board is used to troubleshoot the A10 3rd Converter, A11 Reference, A12 Synthesizer, and A13 Front End Driver assemblies.

Refer to [Figure 5-1](#). There are eight SMB connectors and eight switches on the E4440-60049 extender board. Each switch controls the signal path at the corresponding connector to allow for signal monitoring and injection. For example, switch S6 controls the signal path for connector P6. The following table shows how the switches work:

Extender Board Switch Positions	
Up - "Board to SMB"	Connects SMB connectors to J2.
Middle - "Board to Mother"	Connects J1 to J2.
Up - "SMB to Mother"	Connects J1 to SMB connectors.

**Figure 5-1 E4440-60049 Extender Board**



**Table 5-1 E4440-60049 Extender Board Jack Descriptions**

Jack #	Signal	Assembly that is extended
P1	600 MHz 300 MHz	A11 Reference Assembly A10 3rd Converter Assembly
P2	600 MHz 300 MHz	A12 Synthesizer Assembly A11 Reference Assembly
P3	50 MHz Calibrator	A10 3rd Converter Assembly
P4	10 MHz Syn	A11 Reference Assembly
P5	10 MHz Opt	A11 Reference Assembly
P6	10 MHz CPU	A11 Reference Assembly
P7	10 MHz FE Driver	A11 Reference Assembly
P8	10 MHz Analog IF	A11 Reference Assembly

## A11 Reference Assembly Description

**Purpose.** The A11 reference assembly provides a phase locked 10 MHz signal to other boards and assemblies in the instrument. The 10 MHz reference is phase locked either to an internal reference source or to an externally applied signal. Any external signal between 1 MHz and 30 MHz can be selected by the user to phase lock the 10 MHz reference signal.

**Signal Path.** The 10 MHz signal is routed to the A12 synthesizer assembly, the A8 analog IF assembly, the A26 CPU assembly, the A13 front end driver board, the option slots on the A25 motherboard, and the rear panel 10 MHz output connector. In addition, a 50 MHz signal and a 300 MHz signal are routed to the A10 3rd converter assembly. The 50 MHz signal is used for calibration purposes, and is switched on when amplitude calibration is performed. The 300 MHz signal is used as a second LO for the 3rd Converter assembly, and is always active.

The reference assembly utilizes a phase-lock loop which provides stabilization for all the internal reference oscillators used throughout the instrument.

The reference assembly performs the following function:

- phase locks the 100 MHz VCXO to, either, an internal 10 MHz frequency reference, or to an external standard, user selectable between 1 MHz and 30 MHz.
- provides a phase-locked 300 MHz ( $100 \text{ MHz} \times 3$ ) 3rd LO signal to the A10 3rd Converter assembly.
- provides a phase-locked 600 MHz ( $100 \text{ MHz} \times 6$ ) signal to the A9 2nd LO assembly.
- provides a 600 MHz ( $100 \text{ MHz} \times 6$ ) signal to the A12 Synthesizer assembly.
- provides the reference unlock detector which, through the A26 CPU assembly, warns the user that the reference lock loop is unlocked.
- provides a phase-locked 50 MHz ( $100 \text{ MHz} \div 2$ ) internal calibrator signal to the A10 3rd Converter assembly.
- provides the 10 MHz phase-locked reference for various assemblies in the instrument.

## 100 MHz VCXO

The 100 MHz voltage controlled crystal oscillator is used as the main reference in the instrument. It is phase-locked with either an internal or external frequency reference. The overall frequency accuracy of the instrument is determined by the accuracy of the frequency reference.

## 300 MHz Outputs

There are two 300 MHz outputs. The first 300 MHz output provides the 3rd LO signal and the LO signal for the IF calibrator on the A10 3rd Converter assembly.

## 600 MHz Outputs

There are two 600 MHz outputs. One is routed to the A12 Synthesizer assembly, and the other is routed to the A9 2nd LO assembly.

## Reference Unlock Detector

If the A11 reference assembly is not receiving the correct reference signal, an unlock error message will appear in red text in the annunciator bar on the front panel. This state is detected by the A26 CPU assembly from the A11 reference assembly.

## 50 MHz Calibrator Output

The 50 MHz ( $100 \text{ MHz} \div 2$ ) internal calibrator is used to perform background calibration on various assemblies in the instrument. This signal is routed to the A10 3rd Converter assembly where it is level shifted.

## 10 MHz Outputs

The 100 MHz VCXO, which is phase locked to a frequency reference, is divided by ten, resulting in a 10 MHz signal. This signal is used on various assemblies in the instrument, including the A26 CPU, A13 front end driver, A8 analog IF, A12 synthesizer assembly, and the 10 MHz output to the rear panel (switched).

## Interconnections to other assemblies

- **A11P1.** External reference input (1 to 30 MHz) from rear panel.
- **A11P2.** 10 MHz output to rear panel.

## Verifying the A11 Reference Board

The instrument achieves its frequency stability from the phase locked circuitry on the A11 reference assembly. The 100 MHz phase locked VCXO is the heart of this assembly. This VCXO is divided by 10 to a phase locked 10 MHz reference for use on several other PC board assemblies in the instrument. The 100 MHz VCXO is also multiplied by 3 for the 2nd L.O. in the RF assembly. The 50 MHz internal calibrator signal is derived from this assembly as well by dividing the 100 MHz VCXO by 2. Verify the 10 MHz references by extending the reference assembly.

### Reference Assembly Quick Check

This procedure checks the 600 MHz output level, the rear panel 10 MHz Ref Out level, and the 300 MHz output at P4.

#### Setup

1. The instrument should be turned on, and a factory Preset performed. Press the green **Preset** key. (If necessary press **System, Power On/Preset, Preset Type** and select Factory.)
2. Assure the instrument is set to internal reference by pressing **System, Reference**, and making sure that the **Freq Ref** key has Int underlined.
3. Turn on the rear panel 10 MHz Ref Out by pressing the **10 MHz Out** key until On is underlined. This will allow the 10 MHz Out signal to be present at the rear panel connector and at the reference board P2 jack.

#### Measure the 600 MHz Out Signal

4. Disconnect the “4” cable (W16, refer to [Figure 10-21 on page 282](#) for the location) from P3 on the reference assembly. Measure P3 by connecting a low loss SMA cable and SMA to SMB adapter between P3 and a spectrum analyzer. The 600 MHz output signal should measure +13 dBm  $\pm$ 3 dB.

---

#### NOTE

A 2nd LO unlock message will appear on the PSA screen. The 600 MHz amplitude measurement is still valid.

5. Reconnect the “4” cable to P3. Clear the 2nd LO unlock condition by performing an Align All Now. Press **System, Alignments, Align All Now**. You will need to clear the error queue to remove the 2nd LO unlock message. Press **System, Show Errors, Clear Error Queue**.



### Measure the 10 MHz Rear Panel Output

6. Connect the spectrum analyzer to the 10 MHz Out (Switched) BNC connector on the PSA rear panel. The 10 MHz signal amplitude should be +6 dBm  $\pm$ 2 dB.

### Measure the 300 MHz Out at P4

7. Connect the spectrum analyzer to P4 on the reference assembly. The 300 MHz amplitude should be -27 dBm  $\pm$ 2 dB.

## Reference Assembly Detailed Troubleshooting

The reference assembly is placed on the E4440-60049 extender board so additional signal levels can be measured.

1. Turn off the PSA and remove the reference assembly from the instrument. Refer to [Chapter 11](#) for removal procedures.
2. Place the reference assembly on the extender board and assure the “4” cable (W16, 600 MHz Out) is connected to P3 on the reference assembly.
3. Turn the instrument on and perform a factory preset.

### Measure the 600 MHz Output to the Synthesizer Assembly

4. Connect a low loss SMA cable and SMA to SMB adapter between P1 (600 MHz) on the extender board and a spectrum analyzer. Set the 600 MHz switch on the extender board in the up position to connect P1 to the 600 MHz output from the reference assembly. The 600 MHz signal should measure -11 dBm.

### Measure the 10 MHz Signals to Other Assemblies

5. Measure the 10 MHz signal listed in the following table. Set the switch controlling the jack to the up position.

Extender Board Jack Designator	Signal Level
P6 10 MHz CPU	+6 dBm
P7 10 MHz FE driver	+3 dBm
P5 10 MHz Option	+3 dBm
P8 10 MHz AIF	+3 dBm
P4 10 MHz Syn	+3 dBm

## A9 Second LO/Fan Control Assembly Description

### Second LO Circuitry

**Purpose.** The A9 second LO assembly generates the 3.9 GHz LO signal that is used by the A20 low band assembly to generate the low band second IF signal of 321.4 MHz. The A9 board also contains unlock detection circuitry, that indicates an unlock condition when it occurs on the assembly.

**Signal Path.** The 600 MHz signal from the A11 reference assembly is routed to a phase detector that compares the phase of the 600 MHz signal with the output of the PMYO.

### Fan Control Circuitry

**Purpose.** The three fans used to cool the various assemblies in the instrument are controlled through circuitry located on the A9 assembly. The speed of the fans varies with changes in internal instrument temperature; as temperature increases, fan speed increases. The front-panel line switch, that turns the power supply on and off, is input from the A9 assembly fan control circuitry. An over-temperature circuit is provided that will turn off the instrument if an over-heating condition in the instrument occurs.

### Interconnections to other assemblies

- **A9J1** 600 MHz input from A11 Reference assembly
- **A9J10** 3.6 GHz output to A20 Lowband assembly
- **A9J11 and J12** Trigger outputs to rear panel

## Verifying the A9 2nd LO/ Fan Control Board

### If the Fans Are Not Operating

**CAUTION**

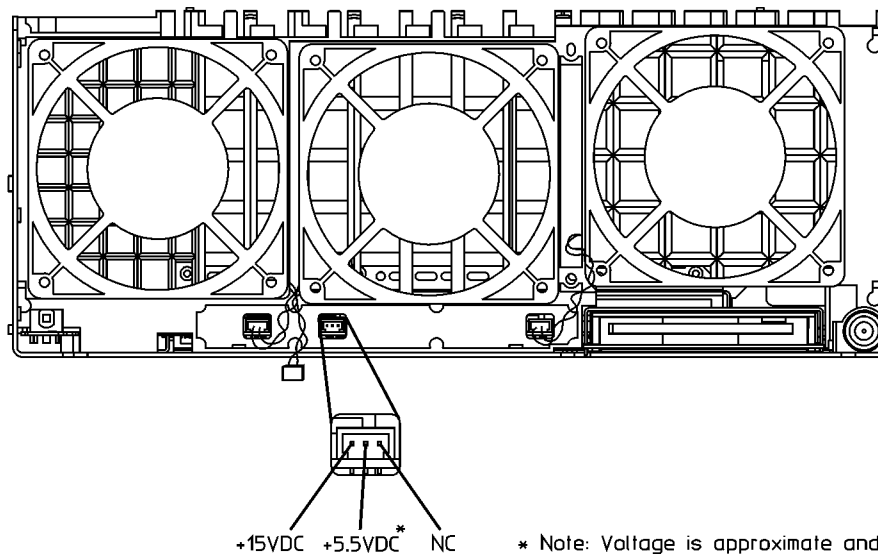
The power supply may be in thermal shutdown if the instrument has been operating without the fans running. Allow the instrument to cool down before troubleshooting.

If all three fans are not operating, suspect a power supply problem or a defective fan control circuit on the A9 2nd LO/Fan Control assembly. Refer to “[A5 Power Supply Assembly Description](#)” on page 153 to check the individual supplies. If the supplies are within specifications, the most probable cause is a defective A9 board. Refer to [Chapter 11](#) for assembly replacement procedures.

If only one or two fans are not functioning, and the power supplies are within specifications, suspect the A9 assembly or a defective fan.

1. Remove the front frame from the instrument. Refer to [Chapter 11](#) for removal procedures.
2. Refer to [Figure 5-2](#). Measure all of the fan voltages at J3, J4, and J5 on the motherboard.

**Figure 5-2** Fan Voltages



\* Note: Voltage is approximate and will vary depending on temperature condition of the instrument.

sa867a

3. If the correct voltage is present and the fan connector is in good mechanical condition, suspect a defective fan. Refer to [Chapter 11](#) for assembly replacement procedures.
4. If the voltage is not present, suspect a defective A9 assembly. Refer to [Chapter 11](#) for assembly replacement procedures.

### **Verifying Correct Input and Output Levels**

Disconnect W16 from J1. Measure W16, 600 MHz from the A11 Reference assembly with a spectrum analyzer. The power level should be +12 dBm.

Disconnect the semi-rigid cable W15 at J10. Measure the 3.6 GHz +2 dBm signal at J10 with a spectrum analyzer. Be sure to use a quality SMA cable to connect the analyzer to J10 to avoid excessive cable loss.

---

## **6 Troubleshooting the IF Section**

## What You Will Find in This Chapter

The following information is presented in this chapter:

1. Theory of operation of the 3rd converter section and the IF section.
2. Isolating the cause of a hardware problem by verifying the functionality of assemblies in the IF section signal path.

---

**NOTE**

*Each of the following sections first describes how the assembly works, then gives information to help you troubleshoot the assembly. Each description explains the purpose of the assembly, describes the main components, and lists external connections to the assembly.*

---

This following sections are found in this chapter:

- Third Converter Assembly Description .....page 127
- Verifying the Third Converter Board.....page 129
- Analog IF Assembly Description.....page 133
- Verifying the Analog IF Assembly Signal Path.....page 136
- Digital IF Assembly Description.....page 139
- Verifying the Digital IF Assembly.....page 141

---

**NOTE**

Information regarding the Option 122 or 140 Wideband IF assemblies can be found under the Hardware Options tab of this service guide.

---

## A10 Third Converter Assembly Description

**Purpose:** The 3rd converter assembly levels the 321.4 MHz IF to compensate for system loss, before mixing the 321.4 MHz IF to a 21.4 MHz IF. The 3rd converter also provides the 50 MHz and the 321.4 MHz calibrator signals.

**Path:** Three inputs supply the 321.4 MHz IF signal to the 3rd converter: (1) an input from the low band assembly, (2) an input from the RYTHM, and (3), an optional IF input from the front-panel on instruments with Option AYZ (external mixing). After input filtering, the variable gain amplification circuitry compensates for system loss. The 321 IF is then mixed with a 300 MHz IF from the reference assembly before being routed to the A8 analog IF assembly. In addition, both the 50 MHz and the 321.4 MHz cal signals are processed through the 3rd converter and routed to the A14 input attenuator.

### Step Attenuator

Provide 30 dB of attenuation available in 2 dB steps.

### System Variable Gain Compensation Circuitry

The variable gain circuitry provides flatness compensation over the frequency range of the analyzer. The gain setting depends on stored flatness compensation values. The frequency response adjustment gathers and stores these values.

### Linearization Circuit

The circuitry that provides flatness compensation for the 321.4 MHz signal is non-linear. The linearization circuit, which is driven by the variable ramp generator on the A13 front end driver board, adjusts the amplification of the variable gain circuitry so that the resulting flatness compensation throughout low and high bands is linear.

### 50 MHz Calibrator ALC

The 50 MHz levelling loop ensures that the  $-25$  dBm, 50 MHz calibrator signal is stable and accurate. This 50 MHz signal is routed to the A14 attenuator for system level calibration. This signal is routed through pin 24 on J8.

### 321.4 MHz Filter

The 321.4 MHz bandpass filter has a 10 MHz bandwidth and image rejection of  $-73$  dBc.

### 321.4 MHz Cal Signal Mixer

The 300 MHz signal from the reference assembly (via the motherboard) is summed with the 21.4 MHz signal received from the A8 analog IF assembly. The 321.4 MHz calibration signal is used during the internal Align All Now routine to calibrate the bandwidth shapes. This signal can be turned on manually on instruments containing Option B7J. See [“Isolating the faulty assembly when the displayed amplitude is incorrect or the instrument fails a gain related Auto Align test”](#) on page 53.

### 3rd Mixer

Down converts 321.4 MHz to 21.4 MHz. The 300 MHz LO signal is provided by the A11 Reference assembly.

### Interconnections to other assemblies

- **A10J1** 321.4 MHz input from A19 RYTHM
- **A10J2** 321.4 MHz input from A20 Lowband assembly
- **A10J3** optional 321.4 MHz input, used on Option AYZ
- **A10J4** to rear panel 321.4 MHz Output, or input to A33, Option H70
- **A10J5** 21.4 MHz to A8 Analog IF assembly
- **A10J6** optional calibrator input
- **A10J7** to A14 attenuator (50 MHz cal out or 321.4 MHz)



## Verifying the A10 Third Converter Board E4440A, E4443A, E4445A, E4446A, E4448A)

Begin the troubleshooting process by examining the instrument overall block diagram. Please note the analyzer settings required to obtain the signal levels printed on the block diagram.

### Third Converter Troubleshooting

#### Input Level Check

1. With the PSA tuned to a  $-25$  dBm, 50 MHz signal, disconnect cable W18 from J2 and connect a spectrum analyzer to W18. Refer to [Figure 10-8 on page 260](#) for locations. The 321.4 MHz signal from the lowband assembly should measure  $-43$  dBm  $\pm 2$  dB. Reconnect W18 to J2.
2. With the PSA tuned to a  $-25$  dBm, 5 GHz signal, disconnect W17 from J1 and connect a spectrum analyzer to W17. The 321.4 MHz signal should measure  $-49$  dBm  $\pm 2$  dB. Reconnect W17 to J1.

#### Output Level Check

3. Connect the spectrum analyzer to J5. The 21.4 MHz signal should be  $-30$  dBm  $\pm 2$  dB. Reconnect W11 to J5.
4. Connect the spectrum analyzer to J4, the 321.4 MHz output port. The signal level should be  $-27$  dBm  $\pm 2$  dB.

#### Measure the 300 MHz 3rd LO

5. Use the extender board E4440-60049 to extend the 3rd converter. Reconnect the cables color coded 3, 7, 10, and 50. A short extension cable may be necessary for the 10 and 50 cables. Allow the instrument to complete the auto-align once the 3rd converter is extended.
6. Connect a spectrum analyzer to P1 on the extender board and set the extender board switch that controls P1 to the down position to measure the  $+10$  dBm, 300 MHz signal

#### 50 MHz Calibrator Level Check

7. Connect the spectrum analyzer to P3 on the extender board. Set the 50 MHz switch on the extender board to the up position. Assure the 50 MHz calibrator is turned on by pressing **Input/Output**, **Input Port**, **Amptd Ref**. The spectrum analyzer should display a  $-40$  dBm signal at 50 MHz.

### Option AYZ IF Input Check

This procedure will check for proper gain through the 3<sup>rd</sup> converter when the external mixing path is enabled.

#### Setting the Synthesized Sweeper Power Level

1. Zero and calibrate the low-power sensor and power meter in dBm mode using the 30 dB reference attenuator. Enter the 300 MHz calibration factor of the power sensor into the power meter.
2. Connect an SMA cable from the output of a source to the power sensor using an adapter between the cable and the power sensor.
3. Set the source frequency to 321.4 MHz. Adjust the source power level for a power meter reading of  $-30 \text{ dBm} \pm 0.1 \text{ dB}$ .
4. Record the power meter reading as Input Power.

Input Power \_\_\_\_\_ dBm

#### Measuring the IF INPUT Accuracy

5. Connect the SMA cable from the RF OUTPUT of the source to the IF INPUT of the analyzer.
6. Press **Preset** on the analyzer. Press **Factory Preset**, if it is displayed. Set the analyzer by pressing the following keys:

**Amplitude, More 1 of 2, Corrections, Apply Corrections No**  
**Input/Output, Input Mixer, Input Mixer Ext**  
**Ext Mix Band, 26.5-40 GHz**  
**FREQUENCY, 30 GHz**  
**SPAN, Zero Span**  
**BW/Avg, Res BW, 1 kHz**

7. Press **Peak Search** on the analyzer. Record the marker (Mkr1) amplitude reading as the Measured Power.

Measured Power \_\_\_\_\_ dBm

8. Subtract the Input Power (step 4) from the Measured Power (step 7) and record the difference as the IF INPUT Accuracy.

IF INPUT Accuracy = Measured Power – Input Power

For example, if the Measured Power is  $-29.98 \text{ dBm}$  and the Input Power is  $-30.08 \text{ dBm}$ , the IF INPUT Accuracy would be  $0.1 \text{ dB}$ .

9. The IF INPUT accuracy should be less than  $\pm 0.3 \text{ dB}$ .
10. If the IF INPUT accuracy exceeds  $\pm 0.3 \text{ dB}$  perform the IF Input adjustment before troubleshooting a faulty 3<sup>rd</sup> converter or variable gain range from the A13 Front End Driver.

---

## Verifying the A10 Third Converter Board (E4447A)

Begin the troubleshooting process by examining the instrument overall block diagram. Please note the analyzer settings required to obtain the signal levels printed on the block diagram.

### Third Converter Troubleshooting

#### Input Level Check

---

**CAUTION**

Do not attempt to disconnect W18 at J2. This cable is not removable.

1. With the PSA tuned to a  $-25$  dBm, 5 GHz signal, disconnect W17 from J1 and connect a spectrum analyzer to W17. Refer to [Figure 10-8 on page 260](#) for locations. The 321.4 MHz signal from the RYTHM assembly should measure  $-49$  dBm  $\pm 2$  dB. Reconnect W17 to J1.

#### Output Level Check

2. Connect the spectrum analyzer to J5. The 21.4 MHz signal should be  $-30$  dBm  $\pm 2$  dB. Reconnect W11 to J5.

#### Measure the 300 MHz 3rd LO

3. Connect a spectrum analyzer to P4 on the A11 Reference board to measure the  $-27$  dBm, 300 MHz signal.

#### 50 MHz Calibrator Level Check (also an alternate method for all PSA analyzers)

4. Remove W20 from J7 on the 3rd converter. Connect a spectrum analyzer to J7. Assure the 50 MHz calibrator is turned on by pressing **Input/Output**, **Input Port**, **Amptd Ref**. The spectrum analyzer should display a  $-25$  dBm signal at 50 MHz.

#### Option AYZ IF Input Check

This procedure will check for proper gain through the 3<sup>rd</sup> converter when the external mixing path is enabled.

#### Setting the Synthesized Sweeper Power Level

1. Zero and calibrate the low-power sensor and power meter in dBm mode using the 30 dB reference attenuator. Enter the 300 MHz calibration factor of the power sensor into the power meter.
2. Connect an SMA cable from the output of a source to the power

sensor using an adapter between the cable and the power sensor.

3. Set the source frequency to 321.4 MHz. Adjust the source power level for a power meter reading of  $-30 \text{ dBm} \pm 0.1 \text{ dB}$ .
4. Record the power meter reading as Input Power.

Input Power \_\_\_\_\_ dBm

### Measuring the IF INPUT Accuracy

5. Connect the SMA cable from the RF OUTPUT of the source to the IF INPUT of the analyzer.
6. Press **Preset** on the analyzer. Press **Factory Preset**, if it is displayed. Set the analyzer by pressing the following keys:

**Amplitude, More 1 of 2, Corrections, Apply Corrections No  
Input/Output, Input Mixer, Input Mixer Ext  
Ext Mix Band, 26.5-40 GHz  
FREQUENCY, 30 GHz  
SPAN, Zero Span  
BW/Avg, Res BW, 1 kHz**

7. Press **Peak Search** on the analyzer. Record the marker (Mkr1) amplitude reading as the Measured Power.

Measured Power \_\_\_\_\_ dBm

8. Subtract the Input Power (step 4) from the Measured Power (step 7) and record the difference as the IF INPUT Accuracy.

IF INPUT Accuracy = Measured Power – Input Power

For example, if the Measured Power is  $-29.98 \text{ dBm}$  and the Input Power is  $-30.08 \text{ dBm}$ , the IF INPUT Accuracy would be  $0.1 \text{ dB}$ .

9. The IF INPUT accuracy should be less than  $\pm 0.3 \text{ dB}$ .
10. If the IF INPUT accuracy exceeds  $\pm 0.3 \text{ dB}$  perform the IF Input adjustment before troubleshooting a faulty 3<sup>rd</sup> converter or variable gain range from the A13 Front End Driver.

## A8 Analog IF Assembly Description

**Purpose.** The A8 analog IF assembly receives a 21.4 MHz signal from the A10 3rd Converter. The 21.4 MHz signal is amplified, pre-filtered, mixed with the 28.9 MHz fourth LO to provide a 7.5 MHz final IF, post filtered, and amplified again.

The analog IF assembly also provides anti-alias filter protection, and routes the 21.4 MHz signal, that is used in ranging, to the A7 digital IF assembly.

The analog IF assembly performs the following functions:

- prefilters the 21.4 MHz third IF frequency
- uses a variable gain amplifier to provide the optimum level to the mixer
- provides a 21.4 MHz anti-alias filter
- provides the final down conversion
- performs post down-conversion filtering
- provides calibrator oscillator and sample rate oscillator
- provides a clock generator
- performs frequency down conversion to 7.5 MHz
- triggering
- provides the power supply switching frequency generator

### Pre-filters

LC and XTAL prefilters are used to attenuate the out of band signals that are not in the measurement bandwidth, in order to improve TOI distortion and spurious responses. The pre-filters are adjusted to 2.5 times the resolution bandwidth, except in RBWs less than 1 kHz and greater than 1.2 MHz. If the resolution bandwidth is less than 1 kHz, the XTAL prefilter bandwidth stays at 2.5 kHz. If the resolution bandwidth is 1.2 MHz or wider, the prefilters are bypassed.

### Main Gain Amplifier

Provides the following functions:

- Sets the gain between the 21.4 MHz input on the Analog IF, to the A7 Digital IF Assembly output. This is accomplished during the Auto Align routine by reading the power detector at the input of the Analog IF assembly. Then, adjusting the main gain until the proper signal level is achieved.
- When the prefilter BW is changed, compensates for amplitude changes.
- When the frequency band is changed, compensates for conversion loss.

## 21.4 MHz Anti-Alias Filter

This filter serves two purposes. First, it rejects the image band at 31.4 MHz to 41.4 MHz. Second, it band limits the signal to a width of 10 MHz, and so provides much of the anti-alias filtering for the ADC.

## Mixer

The third mixer converts the incoming 21.4 MHz third IF down to the final IF at 7.5 MHz. This is accomplished by mixing the 21.4 MHz third IF with a 28.9 MHz LO. The difference frequency is 7.5 MHz.

## Fourth L.O.

The 28.9 MHz LO signal is phase locked to the 10 MHz frequency reference from the A11 reference assembly.

## Post Down Conversion Filtering

There are two post-mixing filters for the 7.5 MHz final IF. The 12.5 MHz low pass filter removes high order mixing products from the third LO, as well as the 21.4 MHz feed-through. The 2 MHz wide, 7.5 MHz band pass filter provides additional filtering for narrow resolution bandwidths, and is used to improve spurious free dynamic-range. The 12.5 MHz LPF is switched in when the pre-filters are bypassed (RBW > 1.2 MHz), or when in LC pre-filter BW 1.41 MHz (RBW 620 kHz) and 2.83 MHz (RBW 1.1 MHz).

## Calibration Generator

Creates a 21.4 MHz signal which is routed to the A10 3rd Converter. The 3rd converter up converts to 321.4 MHz and this signal is used during the auto align routine for the adjustment of the filter bandwidths and amplitude settings of the AIF and DIF assembly.

---

**NOTE**

Press: **System, Alignments, Align All Now** to execute the auto align routine.

---

## Clock Generator

The clock is a 30MSa/s differential ECL clock that is distributed on the motherboard to the digital IF as SR\_L and SR\_H (Sample Rate low and high). The clock generator is locked to the 10 MHz reference signal.

## **Triggering**

The analog IF assembly has a second IF strip for generating triggers.

## **Power Supply Switching Reference**

This circuit provide a 244 kHz switching frequency to the A5 power supply. The A5 power supply divides this frequency in half, therefore, the power supply switching rate is 122 kHz.

## **Interconnections to other assemblies**

- Front panel external trigger input at P4
- Rear panel external trigger input at P1

## Verifying the A8 Analog IF Assembly Signal Path

This procedure assumes the A10 3rd Converter assembly is functioning correctly. To verify proper 3rd Converter functionality, refer to the “Verifying the A10 Third Converter Board E4440A, E4443A, E4445A, E4446A, E4448A)” on page 129.

### Analog IF Assembly Quick Check

1. Inject a  $-25$  dBm, 50 MHz signal into the RF input of the instrument.
2. Press **Preset** on the instrument and tune to 50 MHz by pressing **Input, Input Port, RF, Frequency 50 MHz**.
3. Press **Amplitude** and set the input attenuation to 0 dB.
4. Disconnect the flexible gray cable (W10) going into the A7 digital IF assembly at A7P1. Refer to [Figure 10-21 on page 282](#) for cable locations.
5. Connect a calibrated spectrum analyzer to the end of this flexible cable, and measure the 7.5 MHz output from the analog IF assembly going to the digital IF assembly.
6. If the analog IF assembly is operating properly, the 7.5 MHz 4th IF out of the Analog IF assembly will measure  $-23$  dBm  $\pm 1$  dB, on the calibrated spectrum analyzer.
7. Reconnect the cable to A7P1.



## Analog IF Assembly Detailed Troubleshooting

If the quick check power level is not correct, or you still suspect the assembly is faulty, other items can be checked to verify the analog IF assembly.

Refer to the instrument block diagram. The incoming 21.4 MHz signal is routed through one of three prefilter paths depending on the instrument resolution bandwidth setting.

A signal level problem may only be visible in certain resolution bandwidths. The table below shows which prefilter path is used at different resolution bandwidth settings.

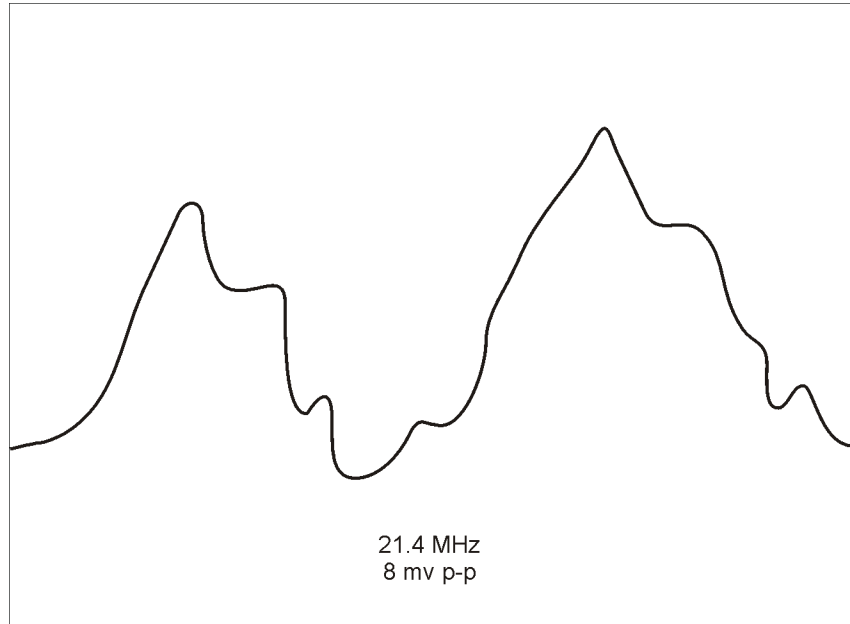
Resolution Bandwidth	Pre-Filter Path
1 Hz to 75 kHz	XTAL
82 kHz to 1.1 MHz	LC
1.2 MHz and above	Bypass

### Main Gain Check

Under the conditions listed on the overall block diagram (CF = 50 MHz), the DAC that adjusts the AIF Main Gain amplifier is typically set to a DAC value between 90 and 1300, depending on instrument model number and hardware version. Current typical values for E4440A/E4443A/E4445A are 500 to 1300. Values for E4446A/E4447A/E4448A are 90 to 300. To view the Main Gain DAC value, enter the service mode, then view the HW Diagnostics. Press **System, More, Service, -49, Enter, Service, More, Diagnostics, HW Diag On, IF Ctrl**. The Main Gain DAC value is displayed on a key. The DAC range is 0 to 4095. If the DAC value is at a range limit, suspect a problem with instrument signal path levels and troubleshoot the signal path.

### Testing the Cal Osc Signal

The 21.4 MHz Cal Osc HI and Cal Osc LO signals are routed through the motherboard to the A10 Third Converter. The E4440-60048 extender board has test jacks for both of these signals. The following waveform was taken using an oscilloscope with a SMB to BNC cable connected to a BNC tee/50 ohm load at the oscilloscope input connector. The waveform is only visible while the Auto Align Now routine is running.



se657a

## A7 Digital IF Assembly Descriptions

Two versions of the A7 Digital IF assembly are available. Instruments with Option 124 (Video Out) or Option 122 or 140 (Wideband IF) contain the optional Digital IF assembly [E4440-60206](#). This assembly requires slightly different troubleshooting techniques than the standard assembly. Therefore when following the procedures below be careful to use the correct information for the digital IF installed in your instrument.

**Purpose:** The A7 digital IF assembly digitizes the 7.5 MHz final IF, by processing the time domain continuous data into I/Q (in-phase and quadrature) signals, and delivers the data to the CPU for further processing and display.

The digital IF assembly performs the following main functions:

- digitizes the 7.5 MHz IF
- pre-adjusts the variable amplifier for optimum ADC input levels using the gain range/select rules circuitry
- performs analog to digital conversion
- performs dither generation
- provides video out (Option 124)
- Final IF overload detection

### 7.5 MHz IF

The 7.5 MHz IF comes from the A8 analog IF assembly. The maximum input level to the A7 digital IF assembly is +4 dBm. Exceeding this level will cause distortion and will clip the ADC causing erroneous measurement results.

### Gain Range Select/Rules

This input path is a tapped 21.4 MHz 3rd IF from the A8 analog IF assembly, which bypasses the 10 MHz anti-alias filters. The gain range of the variable amplifier before the ADC is 0 to 18 db (in 6 dB steps). The gain range select/rules “pre-adjusts” the variable amplifier for optimum ADC input levels before the 7.5 MHz third IF arrives at the ADC. Overdriving the ADC will cause distortion and will clip the ADC, resulting in erroneous measurements.

### Offset Adjust and Dither

These signals are requirements for the complex ADC chip to function properly. The dither generator adds noise to the ADC, which converts quantization errors into noise, and the noise on the signal can be removed.

## Interconnections to other assemblies

- **A7P1** 7.5 MHz in from A8 Analog IF assembly.
- SR\_H (Sample Rate High) and SR\_L (Sample Rate Low) clock signals from the A8 Analog IF assembly.

## Verifying the A7 Digital IF Board

This procedure assumes the A10 3rd Converter assembly and the A8 analog IF assembly are functioning correctly. To verify proper functionality, refer to the “[Verifying the A10 Third Converter Board E4440A, E4443A, E4445A, E4446A, E4448A](#)” on page 129 and “[Verifying the A8 Analog IF Assembly Signal Path](#)” on page 136.

Evaluating the performance of the digital IF board involves:

- measuring the input signal prior to the analog to digital conversion.
- verifying proper clock signals.

### Digital IF Assembly Quick Check

The A7 digital IF assembly requires a 30 MHz clock from the A8 analog IF assembly or the instrument will not boot.

1. Inject a  $-25$  dBm, 50 MHz signal into the RF input of the instrument.
2. Press **Preset** on the instrument and tune to 50 MHz by pressing **Input, Input Port, RF, Frequency 50 MHz**.
3. Press **Span, Zero Span**.
4. Set the input attenuation to 10 dB. Press **Amplitude, Attenuation** and enter 10 dB.
5. Connect a calibrated spectrum analyzer to A7TP5 (for E4440-60025 or E4440-60195). If A7 is E4440-60206, connect to P202.
6. The 7.5 MHz IF power level at A7TP5 should measure  $-21$  dBm  $\pm 2$  dB on the calibrated spectrum analyzer if the circuitry up to the ADC is operating correctly.
7. Check the other ADC range settings by entering the service mode and selecting each range.
8. Press **System, More, Service, -49, Enter, Service, More, Diagnostics, HW Diag On, ADC Range Manual**.

ADC Range	Power Level @ TP5 $\pm 1$ dB
0 dB	$-39$ dBm
+6 dB	$-33$ dBm
+12 dB	$-27$ dBm
+18 dB	$-21$ dBm
None	N.A.

9. If your instrument contains Option 124 Video Out, See the Option 124 Troubleshooting section of this service guide for details on verifying the video out port.

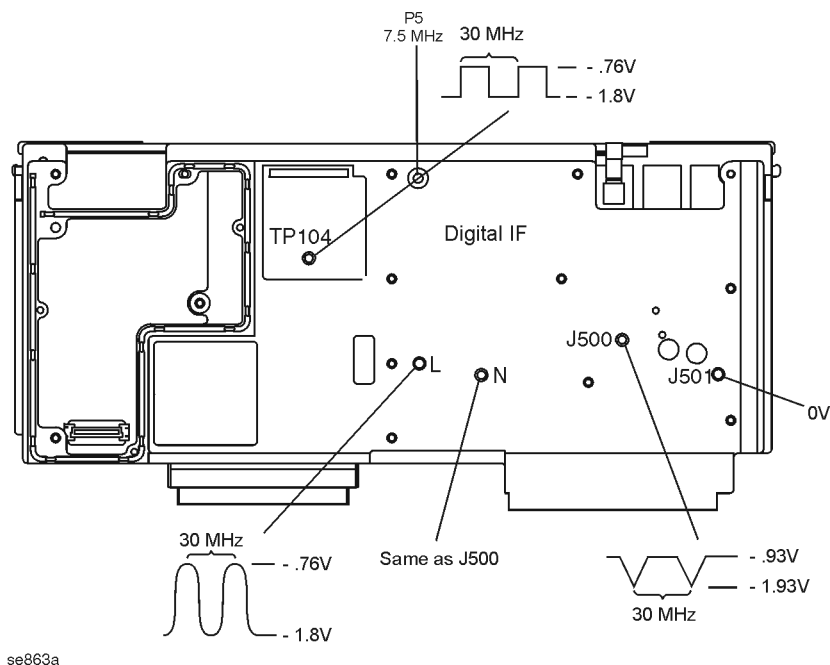
## Digital IF Assembly Detailed Troubleshooting

If the quick check power level is not correct, other items can be checked to verify the A7 digital IF assembly.

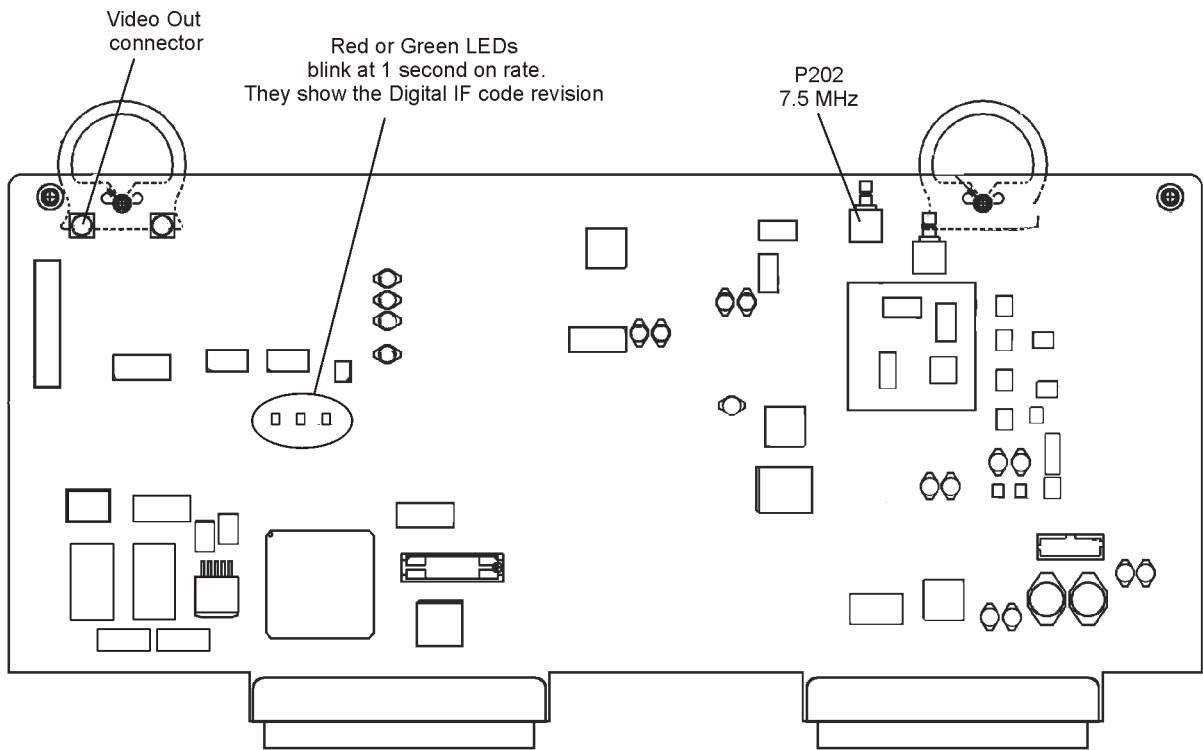
The remaining detailed checks require the digital IF assembly to be placed on an extender board (p/n E4406-60021). Turn the instrument off before removing a PC board assembly from the instrument.

Measure the voltages on the extender board. If the levels are incorrect, or the clock measurements (using an oscilloscope) from [Figure 6-1](#) are incorrect, suspect the A7 digital IF assembly as being defective.

**Figure 6-1** A7 Clock Measurements (E4440-60025, E4440-60195)



**Figure 6-2** A7 Clock Measurements Options 122 or 140, and 124  
(E4440-60206)



Troubleshooting the IF Section  
**Verifying the A7 Digital IF Board**



---

**7**

**Troubleshooting the Processor,  
Power Supply, and Display**

## What You Will Find in This Chapter

The following information is presented in this chapter:

1. Theory of operation of the CPU, power supply, and display sections along with descriptions of the motherboard, front panel interface assembly and SCSI Interface board.
2. Isolating the cause of a hardware problem by verifying the functionality of assemblies in these sections.

---

**NOTE**

*Each section first describes how the assembly works, then gives information to help you troubleshoot the assembly. Each description explains the purpose of the assembly, describes the main components, and lists external connections to the assembly.*

---

This following sections are found in this chapter:

- Motherboard Description.....page 147
- CPU Assembly Description .....page 148
- Verifying the CPU Assembly .....page 149
- Power Supply Description .....page 153
- Isolating a Power Supply Problem .....page 154
- SCSI Interface Board Description.....page 158
- Front Frame Description .....page 159
- Keyboard Description .....page 159
- Front-Panel Interface Description .....page 159
- Display Description.....page 159
- Disk Drive.....page 159

## **A25 Motherboard Description**

**Purpose.** The A25 Motherboard provides the following functions:

- Provides a load to the power supply assembly for the +9 V, -5.2 V, -15 V, +5.2 V supply lines. This allows a minimum set of PC board assemblies to be present for power supply operation. See the power supply troubleshooting section of this manual for a list of minimum assemblies required. This will help isolate power supply problems.
- Provides regulated +12 V and -12 V supplies to the CPU assembly.
- Provides interconnections between many assemblies.
- Location of the on/off switch.

## A26 CPU Assembly Description

**Purpose.** The A26 CPU (processor) assembly consists of three boards: the base CPU processor board, the A26A1 128M DRAM card, and the A26A2 Flash memory board.

The operating system, the main firmware, measurement applications, and the IP address and saved states, are stored in Flash memory. If the original CPU board fails, all this information can be transferred to a replacement CPU board by transferring the A26A2 Flash board.

The CPU board contains the instrument serial number.

There are several I/O connections on the rear panel of the instrument. Many of these connectors are soldered directly into the CPU board or plug into the CPU. These connections include the following:

- SCSI-2 connector. (Factory use only)
- Parallel interface connector. Used to connect the instrument to a parallel printer.
- LAN connector. Used for instrument control and for downloading firmware into the instrument.
- GPIB. Used for instrument control and automated testing and remote control operation.
- Keyboard connector. Used for connecting an external PS-2 keyboard. Keyboard functionality is limited to factory/field service.
- RS-232 connector. (Factory use only)
- VGA monitor output connector. Used to connect an external, non-interlaced VGA compatible monitor with a signal that has 31.5 kHz horizontal/60 Hz vertical synchronization rate.

---

## Verifying the A26 CPU Assembly

The A26 CPU assembly slides into the instrument from the rear and connects to the A25 Motherboard assembly. The GP-IB interface connector, LAN connector, RS-232 connector, Parallel Interface connector, and the external VGA monitor output connector are all soldered directly onto the CPU board. If you want to remove the CPU assembly from the instrument, several assemblies must be removed before sliding the CPU out. Refer to [Chapter 11](#) for removal instructions. There is no extender board for the CPU assembly.

---

**NOTE** The replacement CPU board DOES NOT include the A26A1 DRAM board or the A26A2 Flash memory board. It is important that these boards be transferred to the replacement CPU board. The Flash contains all of the instrument firmware, plus any options and option keywords loaded into the instrument.

---

**NOTE** If you are troubleshooting a frozen keyboard, start by verifying the A26 CPU assembly. If the CPU is found not to be the cause of the problem, suspect the A2 Front Panel Interface or the ribbon cable that connects the motherboard to the A2 Front Panel Interface assembly.

---

## CPU Assembly Quick Check

Following power-up, the instrument will perform a boot process as follows:

Once power is applied to the instrument, the screen will remain blank for several seconds.

Text begins to scroll by on the instrument display as the instrument boots from the bootrom. During this time you will see information on the screen, such as what the primary and alternate boot paths are, what the keyboard path is, and messages that indicate the autoboot process has started and the CPU is booting. When the message `HARD booted` appears, the instrument has stopped booting from bootrom and is now booting from the main Flash.

If DRAM is bad, there will be a memory check sum error or size mismatch. If Flash memory on the CPU is bad, an IPL error may occur and the on screen message is often `"Main menu: Enter Command"`.

Next, a series of keys appear on-screen and the instrument loads its operating system. More messages appear which tell you what is happening during the boot process. During this time the instrument is looking for LAN connections and checking for a floppy disk in the disk drive.

The message “LAN timeout; External loopback test failed” indicates the instrument didn’t sense a LAN connection.

A gray screen appears for about 15 seconds. Next a screen appears with the instrument model number and firmware revision information. This screen may be displayed for 2 minutes.

If the boot process hangs up here, reload the PSA firmware.

Once the boot process is complete, the instrument runs the auto-align procedure documented on [page 49](#).

If the instrument does not boot, look to see if the LEDs on the CPU assembly are flashing. When the instrument power is turned on, you can observe the processor LEDs from the rear panel access holes by the LAN connector. At power on, the CPU DIAG LEDs behave as follows:

- At power on, all four LED’s turn on for a second.
- The left most LED turns off leaving the other three LED’s on for approximately 15 seconds.
- The three LED’s go off and the left LED turns on.
- The LED’s go through a flashing sequence.
- All four turn on for approximately 10 seconds.
- All CPU diagnostic LED’s turn off after the boot-up is complete.

At the end of the sequence, all of the green LEDs should be off. If one or more of the green LEDs remains on, suspect the CPU assembly as being defective. If a LAN connection is present, the yellow “LAN CO LI” LED remains on. The yellow “RX” LED will blink.

If the screen remains blank (dark) and the green LEDs never blink, the instrument was not able to boot from bootrom. The bootrom on the CPU assembly could be bad, or the instrument clock signals could be missing. The bootrom is not a replaceable part.

If the 30 MHz sample clock from the A8 Analog IF assembly to the A7 Digital IF assembly is not present, the display signal processor chip on the digital IF assembly will not reset, causing the PCI bus to hang up and the instrument will not boot.

To check the 30 MHz sample clock:

- Put the A7 Digital IF assembly on an extender board (E4406-60021).
- Check A7J4 for a 30 MHz signal using an oscilloscope, as shown in [Figure 6-1 on page 142](#).
- If the signal is not present, the cause could be the A8 Analog IF assembly, or the A11 Reference assembly. Go to ["A11 Reference Assembly Description" on page 118](#) to check the reference assembly.

If the boot-up process stops after the message Processor starting

auto-boot process appears, the firmware files on the A26A2 Flash board may be defective. Try loading new firmware before replacing the A26 CPU or A26A2 Flash assemblies.

Suspect the DRAM (A26A1) board is not seated correctly or the board has failed if 3 green LEDs on the CPU board remain on and the following message displayed on screen:

```
CPU0
```

```
WARNING: Self tests have been disabled as a result of  
FASTBOOT being enabled. To enable self tests, use the  
FASTBOOT command in the CONFIG. menu and reboot the  
system.
```

```
WARNING: One or more memory banks were not configured due  
to a SIMM size mismatch or a SIMM failure. For more  
details, use the MEMORY command in the CONFIG. menu.
```

Look at the instrument screen and read any error messages that might appear. The messages can give you a clue as to what is happening when the instrument hangs up.

## CPU Assembly Detailed Troubleshooting

There are a few items that should be checked before suspecting a defective CPU assembly. The CPU must have all the DC power supplies coming from the motherboard. Carefully measure the DC supplies on the motherboard at the N12 and P12 test point pads. The test points are located near the digital IF connector. These two supplies come from a regulator circuit on the A25 Motherboard.

Also measure the VCC and VDL supplies by inserting the E4406-60021 extender board into option slot 2, next to the digital IF assembly. Measure VCC (+5.2 V) and VDL (+3.4 V) using DCOM for the ground connection. VCC and VDL voltages come from the A5 Power Supply.

If the power supplies measure correctly, and the CPU does not boot properly, the I/O lines could be loaded down by another assembly, or a clock signal could be missing. Remove the A7 Digital IF assembly and try rebooting. The A8 Analog IF assembly must be installed and providing the 30 MHz sample clock before the CPU will boot. See [page 150](#) for troubleshooting hints.

If the instrument will still not boot, suspect the A26 CPU assembly is faulty.

## Battery Information

The analyzer uses a Lithium Polycarbon Monofluoride battery to power the instrument clock/calendar and to backup the NVRAM on the CPU assembly. If the power cord has been disconnected for several hours, and then the power cord re-connected and the instrument powered up, the first sign of a depleted battery is the on-screen time and date read out are incorrect. The date reverts to 1970. Also, you may see the message "Restoration of NVRAM" on the display status line. This message occurs when the contents of NVRAM do not match data stored on other assemblies, and this results in the NVRAM being updated.

The battery is located on the CPU assembly. See A26BT1 in the Replacement Parts section of this manual. To replace the battery, it is necessary to remove the CPU assembly. Refer to [Chapter 11](#) for removal procedures.



## A5 Power Supply Assembly Description

**Purpose.** The A5 Power Supply assembly is a switching power supply that operates at a switching frequency of 121.95 kHz. The power supply automatically senses the input power and selects between two voltage ranges, 90 to 132 VAC or 195 to 250 VAC.

A low TTL level on the PS\_off\_L line turns off the power supply and places it in standby mode. In standby mode, the front panel standby LED is powered on by the P15SBY line from the power supply. When the power supply is on, the “power on” front-panel LED is powered by the 5.2 V supply.

The power supply plugs directly into the motherboard. The power supply output voltages are: +5.2 V, -5.2 V, +9 V, +15 V, -15 V, +32 V, VCC (5.2 V for processor) and VDL (3.3 V to processor).

---

## Isolating an A5 Power Supply Problem

---

**NOTE**

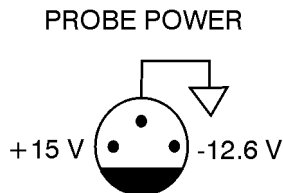
There are no fuses to replace within the power supply. If you determine that the power supply is the failed assembly, replace the power supply.

Observing the LED on the front of the instrument, and measuring the probe power connector, will determine if there is catastrophic failure in the power supply assembly.

1. Ensure the instrument is plugged in with the power switch in the Standby position (power not switched on). Verify that the yellow LED next to the power switch is lit. A lit yellow LED indicates the +15 VDC line (P15 STB) is providing enough voltage to light the LED. (The actual voltage may not be +15 VDC.)
2. Power on the instrument and verify that the green LED on the front panel is lit. A lit green LED indicates the power supply has received an "ON" command and that the +5.2 VDC supply can at least light the LED.
3. The front panel probe power connector can be used to check the +15 VDC and -12.5 VDC (-15 VDC) supplies. The -12.5 VDC is produced by post regulating the -15 VDC supply. Refer to [Figure 7-1](#) for a diagram of the probe power connector.

**Figure 7-1**

**Probe Power Connector**



sa869a

If all of these supplies seem dead, it is likely that the problem is a defective power supply assembly, or some other assembly is loading down the power supply. Continue with ["If All Voltage Supplies Are Dead" on page 155](#), to determine the cause of the problem.

If the correct LEDs are lit and the probe power voltages measure within the specifications, the power supply has not suffered a catastrophic failure; however, the power supply could still be at fault. Continue with the next section to measure the individual voltage supplies.

## Verifying the Individual Voltage Supplies

If any one individual supply line from the power supply assembly develops an over voltage/current problem, all supply lines are affected. The supply will go into a “burp” mode where the supplies will cycle on and off at a low voltage level. The cause of the over voltage/current condition can be the supply itself or any assembly that the power supply provides voltage to. If the power supply is in the “burp” mode, continue with the assembly removal process as described in the section titled ["If All Voltage Supplies Are Dead" on page 155](#).

---

**WARNING**

**The instrument contains potentially hazardous voltages. Refer to the safety symbols provided on the instrument, and in the general safety instructions in this guide, before operating the unit with the cover removed. Ensure that safety instructions are strictly followed. Failure to do so can result in severe or fatal injury.**

---

In order to measure the power supply voltages, it is necessary to remove the instrument’s outer case and top brace. Refer to [Chapter 11](#) for removal procedures. Use the E4406-60021 extender board to measure the individual power supply voltages. Assure the test pins on the board are not bent and touching each other. Insert the extender board into the empty slot next to the digital IF board. Use the point marked as “ACOM” for the ground connection.

### If All Voltage Supplies Are Dead

The power supply may be faulty, or one or more assemblies are pulling down the supplies. In this case it is necessary to sequentially remove or unseat the assemblies, taking care to disconnect the line-power cord before removing or unseating any assembly. Unseating the vertical assemblies is done by first assuring the assembly is not screwed in, such as the A12 Synthesizer or A6 SCSI assemblies. Also assure there is enough cable length to pull the assembly up a few inches. Unseat the assembly using the metal extractors attached to the corners of the casting covers. Assure the assembly is clear of the motherboard connectors. Verify the supply each time (measuring on the E4406-60021 extender board).

After an assembly is disconnected or removed, plug the line-power cord back into the instrument and re-measure the supply that was down. If it is still down, continue with the assembly removal.

---

**NOTE**

If the supply is now up, suspect the last assembly removed as being defective.

---

Remove these assemblies first  
(refer to [Chapter 11](#) for removal instructions):

- A11 Reference assembly
- A12 Synthesizer assembly
- A10 Third Converter assembly
- A7 Digital IF assembly
- A9 Second Converter assembly
- A8 Analog IF assembly

Other assemblies to remove include:

- A13 Front End Driver - the front end driver supplies voltages to the RF section assemblies and the input attenuators. Therefore, if the problem goes away upon removing the front end driver, suspect any of the assemblies it provides voltages to.
- A6 SCSI
- A2 Front Panel Interface assembly - (disconnect the ribbon cable)
- A23 Floppy Disk Drive

The **Minimum Assemblies** required to power up the instrument are:

- A25 Motherboard
- A5 Power Supply assembly
- A26 CPU assembly

---

**NOTE**

To further isolate the failure in the remaining “minimum assemblies”, measure the resistance (with the power turned off) from the power supply test points on the digital IF extender board to ACOM on the extender board. Make the measurements with the digital IF board removed from the extender board.

Check for shorts (zero  $\Omega$ ) or very low resistance (approx. 1  $\Omega$ ). If a short or low resistance is measured, pull the remaining boards from the instrument in the following order, and recheck the shorted test point after each board is pulled. Note that the resistance will be different from the table, but you should be able to tell if the shorted condition has changed. First pull the A26 CPU assembly, and finally the A5 Power Supply.

---

Supply	Approximate Resistance ( $\Omega$ )
+5.2 VDC	41
-5.2 VDC	47
+15 VDC	366
-15 VDC	141
+9 VDC	78
+32 VDC	939

## A6 SCSI Interface Board Description

**Purpose.** The SCSI board assembly plugs directly into the A26 CPU assembly. The SCSI board assembly provides a connector for an external keyboard. This keyboard connector is compatible with an external AT style PC keyboard.

## **Front Frame Description**

**Purpose.** The front frame assembly contains the following four assemblies.

### **A1 LCD Display**

The LCD display assembly provides annotation, graticule, and trace information, as processed by the CPU through the A2 Front Panel Interface board.

### **A3 Keyboard**

The keyboard allows entry of keyboard characters, immediate activation of some features including the print, restart, and display navigation features, and selection of some softkey menus.

### **A2 Front Panel Interface Assembly**

The front panel interface board interprets which key has been pressed, and provides voltage supplies to the inverter boards, the RPG tuning circuitry, and the probe power bias voltage outputs. The front panel interface assembly is comprised of three boards. The A2A1 and A2A2 Inverter boards are identical. The inverter boards provide a stepped-up voltage to both backlights on the LCD display.

### **A23 Disk Drive**

The disk drive is used to download information from a 3.5 inch floppy disk to instrument memory, and to load information from the instrument onto a floppy disk.

## Isolating a Display Problem

---

**NOTE** There are no front panel adjustments for intensity and contrast of the LCD.

---

1. Verify the instrument went through a complete power-on sequence. Refer to "[Troubleshooting Power-up Problems](#)" on page 46.
2. If the display is dark, (not visible), connect an external VGA monitor to the rear panel VGA output connector on the instrument. Some multisync monitors might not be able to lock to a 60 Hz sync pulse. If the video information is not present on the external VGA monitor, the most probable cause is the A26 CPU assembly.
3. If the external VGA monitor is functioning, verify that the front panel ribbon cable (W2) is properly plugged into the motherboard.
4. If W2 is properly connected, suspect cable W5 from the LCD display, a defective A2 Front Panel Interface board, one or both of the inverter boards (A2A1 and A2A2) mounted on the interface board, or the LCD assembly itself (A1).

## Verifying the Inverter Boards

---

**WARNING** **High voltage is present on the inverter boards and the front panel interface board. Be careful when measuring the following signals and voltages.**

---

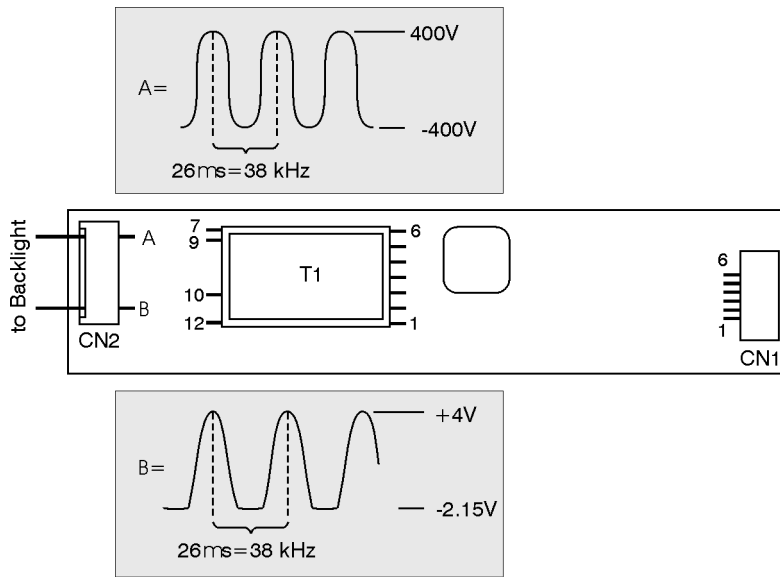
**NOTE** In order to access the front panel boards for measurements, it is necessary to drop the front frame from the deck and remove the front frame shield. Refer to [Chapter 11](#) for these procedures.

---

Measure the signals and voltages as indicated in [Figure 7-2](#). If the signals and voltages measure good, the inverter boards are functioning correctly.



**Figure 7-2 Verifying the Inverter Boards**



sa870a

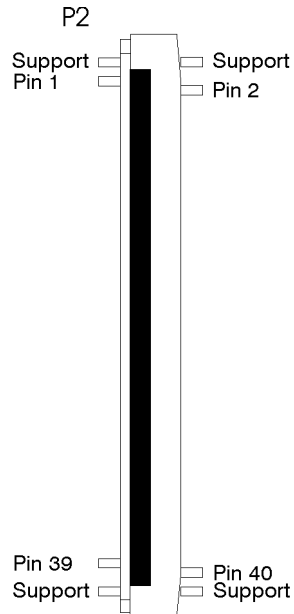
Test Point	Signal or Voltage	Test Point	Signal or Voltage
CN1 pin 1	+4.9 Vdc	T1 pin 4 (input)	+3.3 Vdc
CN1 pin 2	+4.9 Vdc	T1 pin 5 (input)	+33.4 mV
CN1 pin 3	26 mV	T1 pin 6 (input)	-.30 Vdc
CN1 pin 4	+33 mV	T1 pin 7 (output)	60 V p-p sinewave @ 38 kHz
CN1 pin 5	+33 mV	T1 pin 9 (output)	77 V p-p sinewave @ 38 kHz
CN1 pin 6	+33 mV	T1 pin 10 (output)	450 V p-p sinewave @ 38 kHz
T1 pin 1 (input)	-.30 Vdc	T1 pin 12 (output)	45 V p-p sinewave @ 38 kHz
T1 pin 2 (input)	+3.3 Vdc	CN2 A	-400 V to +400 V sinewave @ 38 kHz (see figure)
T1 pin 3 (input)	+3.3 Vdc	CN2 B	-2.15 V to +4 V sinewave @ 38 kHz (see figure)

## Verifying HSYNC, VSYNC, and LCD Clock

To verify that the HSYNC (horizontal sync), VSYNC (vertical sync), and LCD clock are functioning correctly, measure the following signals as indicated in [Figure 7-3](#). If all of these signals measure correctly, suspect a defective backlight or LCD. The backlight is the most probable cause.

---

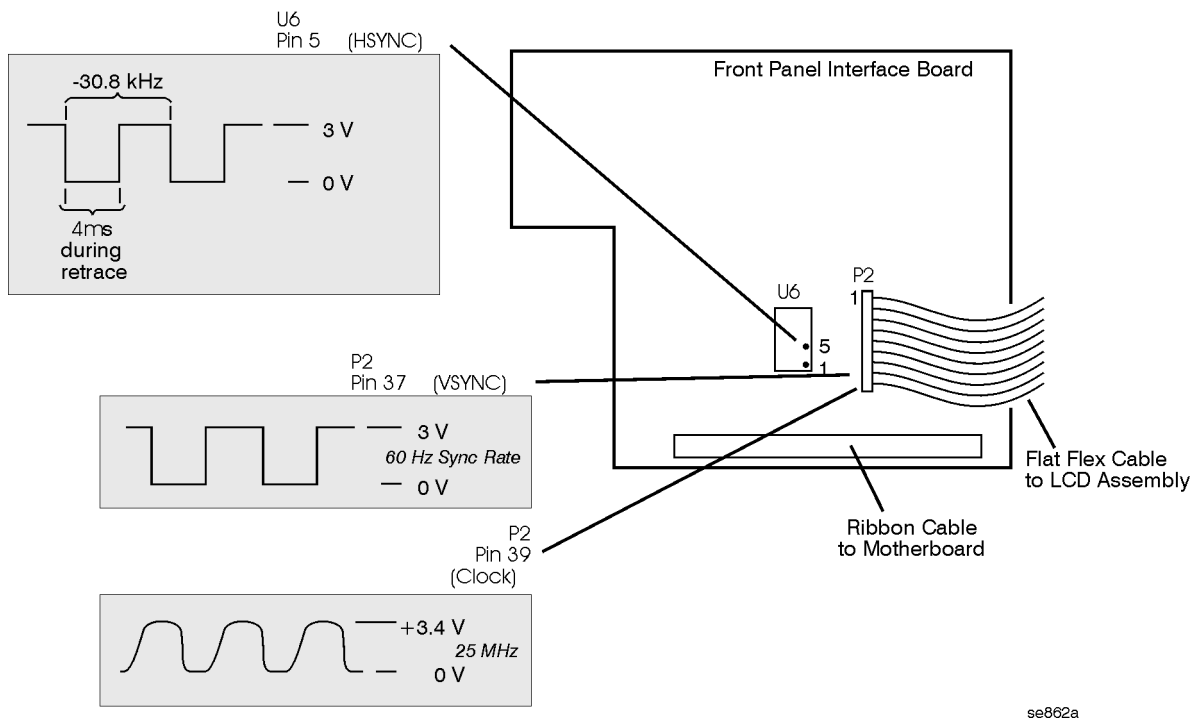
### NOTE



sa871a

The P2 connector on the front panel interface board has supports soldered at each end, as shown in the figure. Make sure to measure the correct pins. Be very careful when measuring these signals to ensure you do not short out any pins.

**Figure 7-3** Verifying HSYNC, VSYNC, and LCD Clock



## Rear Panel Description

The following connectors are located on the rear panel of the instrument:

**PRE-SEL OUT.** Preselected External Mixer Tune output, allows tuning voltage for a Preselected mixer.

**EXT REF IN.** The external reference allows you to select an external reference to phase lock all oscillators in the instrument. You can select any external reference frequency between 1 and 30 MHz. The A11 Reference assembly then converts any external reference frequency to 10 MHz. An Ext Ref message will appear in the upper right hand corner of the display when the external reference is selected. If no external reference signal is applied, or if the operator does not enter the correct value for the external reference frequency, a Frequency Reference Unlock message will appear on screen.

**10 MHz OUT (SWITCHED).** The 10 MHz out allows you to lock other test equipment to the same frequency reference that is being used by the transmitter tester. The 10 MHz out signal is at +5 dB. Once the 10 MHz out is set to On, it will persist in an On state until an Off state is selected.

**2nd IF OUT.** The 321.4 MHz IF signal is routed from the A10 3rd Converter assembly. See the block diagram for power level with -25 dBm input signal and 10 dB input attenuation.

**70 MHz IF OUT.** (Option H70 only) The 70 MHz IF OUT signal is provided by the A33 70 MHz IF OUT assembly located in Option Slot 2. With a -25 dBm input signal and 10 dB input attenuation, the 70 MHz IF OUT signal should measure around -30 dBm.

**TRIGGER OUT (1 + 2).** Trigger outputs used to synchronize other test equipment with the analyzer. Trigger 1 is the High+Sweeping (HSWP) signal.

**TRIGGER IN.** Allows external triggering of measurements.

**NOISE SOURCE DRIVE OUT +28V (PULSED).** Provides +28V supply for a noise source when Option 219, Noise Figure Measurement is installed.

---

  
**8** **Hardware Options**

## What You Will Find in This Chapter

The following information is found in this chapter:

1. Procedures to verify the functionality of each option.
2. Block diagrams of each option.

The following descriptions are found in this chapter:

Verifying Option 107 Audio Input	page 167
Verifying Option 110	page 169
Verifying Option 122 or 140, Wide Bandwidth Digitizer	page 174
Overview and Verification of Option 123, Microwave and Millimeter Preselector Bypass	page 187
Verifying Option 124, Y-Axis Video Out	page 203

---

### NOTE

See “[Instrument Hardware Option Descriptions](#)” on page 16 for overviews of Options 122 or 140, 123, and 124.

See [Chapter 3](#) for information on:

- Option B7J, Digital Demod hardware
  - Option 1DS, Lowband Preamplifier
  - Option AYZ, External Mixing
  - Option BAB, 3.5 mm input connector
-

## Verifying Option 107 Audio Input

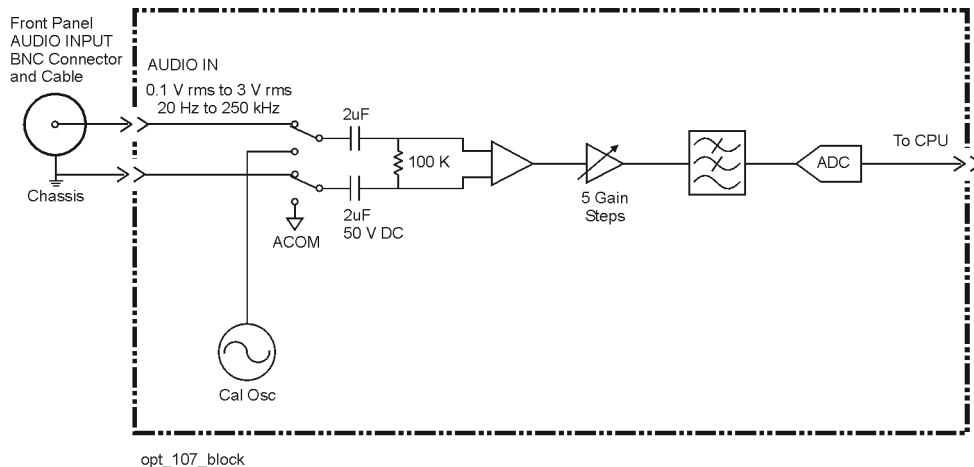
The PSA must have Option 233, Measuring Receiver Personality installed in order to enable Option 107, the Audio Input. Option 233 will always be present since the Audio Input Option 107 is only available on instruments that have Option 233. Option 233 is the built-in measuring receiver personality that is required for a PSA that is part of the N5531S Measuring Receiver System. Unlike many measurements where you can see a trace or waveform, the results of the audio measurement are displayed as numbers on screen. Measurements include: Audio Distortion, Audio Frequency, Audio AC Level, and Audio SINAD.

Option 107 consists of an Audio board and a front panel BNC connector. The Audio signal path is in addition to, and completely bypasses the normal RF/IF signal chain. The frequency range is 20 Hz to 250 kHz. Usable amplitude range is 0.1 V rms to 3 V rms. The input impedance of the audio input is 100 k ohms. The effect of this 100 k ohm input impedance is important to take into consideration when making measurements since most test equipment such as a function generator has 50 ohm input impedance. Therefore, if a function generator with 50 ohm input impedance is set to a particular output level and connected to the Audio Input port of the PSA, the PSA Audio AC Level measurement will yield a reading that is two times the function generator setting.

The Audio signal comes from the front panel BNC connector, goes to the Audio board where the signal is buffered, level shifted (5 gain levels provide best signal to ADC), then run through an ADC followed by an FPGA (a custom gate array) that provides filtering and decimation to the ADC bits. The time domain FPGA bits are sent to the PSA CPU assembly via the PCI bus and the results of the measurement are displayed on screen.

Figure 8-1

### Option 107



## Verification of Option 107

PSA settings:

- Press the front panel **Mode** key
- Select the **Measuring Receiver** key
- Press **Measure** key
- Select **Audio AC Level**

Function Generator settings:

- Output level: 1.5 V rms
- Frequency: 1 kHz

You are going to measure the output level of a source at 5 different levels where each output level activates a different gain stage in the Audio board. This will verify the audio board gain stages and signal processing path.

Connect a function generator to the Audio input on PSA. This test assumes a function generator with 50 ohm output impedance which will cause the PSA to measure 2 times the function generator setting. If you wish, you can also connect a voltmeter such as an Agilent 3458A to the function generator using a BNC tee, and since the voltmeter and PSA both have high input impedance relative to the function generator, both the PSA and voltmeter will display the same voltage.

<b>Function Generator Amplitude</b>	<b>Expected PSA AC Level Measurement</b>
1.5 V rms	3.0 V rms
0.75 V rms	1.5 V rms
0.375 V rms	0.75 V rms
0.187 V rms	0.375 V rms
0.090 V rms	0.180 V rms



## Verifying Option 110

### 100 kHz to 26.5 GHz Preamplifier (E4440A/43A/45A)

### 100 kHz to 50 GHz Preamplifier (E4446A/47A/48A)

Option 110 provides approximately 30 dB of preamplification on the PSA series spectrum analyzers. The range of operation is from 10 MHz to the upper frequency of the spectrum analyzer. Option 1DS, the 100 kHz to 3 GHz preamplifier, cannot reside in the instrument when Option 110 is present. Although Option 110 has the same lower frequency range as Option 123, Option 110 is more expensive and has slightly different specifications. Therefore, Option 110 will not replace Option 1DS in all cases.

There are two Option 110 preamplifiers. The 26.6 GHz microwave version is used on the E4440A, E4443A and E4445A. The 50 GHz millimeter version is used on the E4446A, E4447A and E4448A. Both amplifiers require the A38 Option Driver assembly for control of the amplifier, including flatness compensation files and control of the mechanical switches that switch the amplifier into and out of the signal path. The mechanical switches are stand alone components and not part of the preamplifier or the option driver board.

## Verification of Option 110

The input level at the preamp should not exceed -30 dBm in order to avoid distortion or overload at the preamplifier and first mixer. Assure the instrument is in Spectrum Analysis mode. To turn on the preamplifier press the **Amplitude** key and select **Int Preamp On**. Turning the preamp on or off should produce an audible “click” that verifies the switch has been energized.

A quick check of the preamplifier consists of viewing a signal on screen and determining if the signal level is correct. Since the preamplifier covers a wide frequency range and the flatness of the amplifier is corrected, it is important to verify the amplifier performance at several frequencies. Above 3.05 GHz, you must perform a Preselector Center (**Amplitude, Presel Center**) to minimize amplitude error due to the “high band” preselector.

Frequency	Measured Amplitude Preamp ON	Measured Amplitude Preamp OFF
200 kHz		
5 GHz		
10 GHz		
15 GHz		

Frequency	Measured Amplitude Preamp ON	Measured Amplitude Preamp OFF
20 GHz		
30 GHz		
40 GHz		
50 GHz		

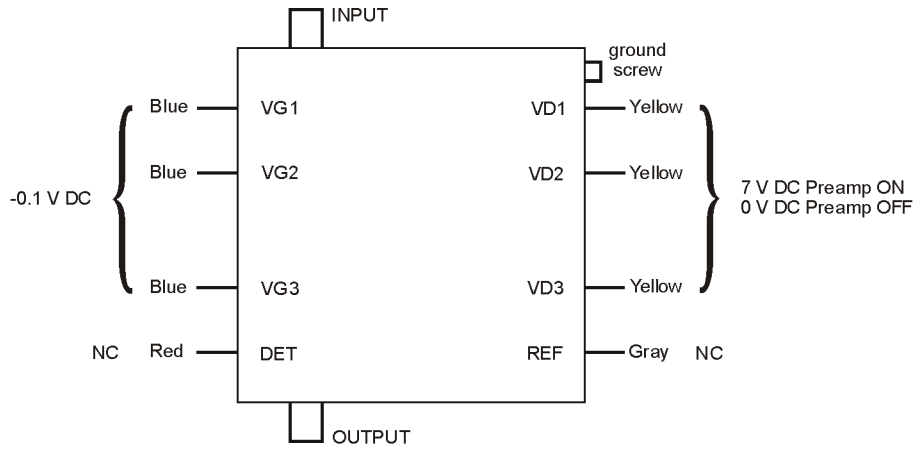
The accuracy of the measured amplitude will depend on the source flatness, quality of interconnect cables and whether you performed Preselector Center, and the frequency response of the PSA. The table above suggests you test with the preamp on, then with the preamp off so you can separate the amplitude variation of the preamp from the test equipment and non- preamp signal path contributions. If the Preamp On amplitude variation between the frequencies in the table above seems large, the problem may be that the frequency response correction factors contained on the A38 Option Driver Assembly are corrupt and need to be replaced by performing the frequency response adjustment.

See the E4446A/E4447A/E4448A Option 110 and Option 123 block diagram or the E4440A/E4443A/E4445A Option 110 and Option 123 block diagram for signal level troubleshooting. Be sure to use the instrument settings listed on the block diagram as a starting point. Run **Align All Now**, then turn **Auto Align Off**. This will allow you to remove cables and troubleshoot without having **Align All** run unexpectedly and change your measured results.

Signal path troubleshooting on the high frequency instruments requires connection to devices with 2.4 mm connectors. A short semi-rigid cable with 2.4 mm male connectors at both ends is recommended. The required test equipment list on [page 24](#) contains the Agilent part number of a cable that can be modified (bent) and used for this purpose.

[Figure 8-2](#) shows the preamplifier pin out/ interconnections and expected voltage levels. All yellow wires carry the same signal and it does not matter which VD1 - VD3 pins the wires connect to. The blue wires all carry the same signal and it does not matter which VG1 - VG3 pins the wires connect to.

**Figure 8-2 Preamplifier Pin Out and Expected Voltage Levels**



opt110\_preamp

## Overview of Option 115 Extended Memory (all PSA Series)

Provides 512 MB of additional memory for optional measurement personalities (such as Option BAF, W-CDMA), user state, trace and screen dumps, and personality power on last state files. This 512 MB of memory is in addition to the 64 MB of flash memory mounted on the CPU assembly. This CPU flash memory contains the instrument core firmware, license keywords, amplitude correction data, limit lines, and network settings.

The extended memory is in the form of a 512 MB compact flash card mounted on the Option 115 extended memory assembly. This assembly also includes the circuitry for Option 111 USB, however USB functionality requires a separate license for it to be enabled.

Because the extended memory /USB assembly also contains the keyboard connector, this assembly will be included in all new instruments, even though the Option 115 or Option 111 are not licensed and are not available for use. Therefore just because the hardware is installed, it does not mean it is functional. You must view the **Show System** screen or the licensing screen to determine which options are available.

---

### NOTE

Option 117, Secure Erase, is designed for security conscious customers. If Option 117 is installed, Option 115 will not be available, even though the memory board with the compact flash card are installed in the instrument. When Option 117 is present, the 64 MB of flash memory on the CPU is mounted read only, and contains the instrument core firmware, all optional measurement personalities (that will fit), license keywords, and network settings. Basically all the files a user cannot store sensitive data into. The 512 MB memory on the extended memory board now contains only the user data such as state, trace or screen dumps, amplitude correction files, power on last state files, and any files a user could store data in. Option 117 allows you to completely erase the contents of the 512 MB flash card by pressing the Secure Erase User key. Since the instrument core firmware is on the CPU Flash card, the instrument will still be functional after erasing the 512 MB memory.

See Option 117 secure memory description in [Chapter 1, "Overview,"](#) for additional information.

---

## Verification of Option 115

Check for the presence of Option 115 by pressing **System, Show System** and looking for 115 in the Options section.

You can also press **System, Licensing, Show License** and see that Option 115 appears in the list.

Press **System, Show Hardware, Next Page** and this will show Compact Flash Type (vendor name / size) and Compact Flash Size (512MB)

If the flash card is defective or missing and cannot be read, you will see the following:

All optional measurement personalities will not be available. Press **Mode** and you will only see Spectrum Analysis. All measurement personality licenses can still be viewed when you press **Show License** as explained above.

The **Show Hardware** screen will not have a **Next Page** key or will not show the Compact Flash Type and Size.

All trace, state and limit files will be missing (assuming some were previously saved). Press **File, Catalog**, and select the different types to verify missing data.

## Verifying Option 122 or 140, Wide Bandwidth Digitizer

The following procedures outline how to place the instrument into wideband mode and verify the signal path is working correctly. Since both the A31 Wideband Analog IF and A32 Wideband Digital IF must work together to provide a signal on screen, both will be tested together here. Troubleshooting hints to determine which of the two assemblies is most likely faulty are included.

**NOTE** Press **System, Show Errors** to check the instrument error queue for possible error messages that resulted the last time the instrument performed an internal alignment.

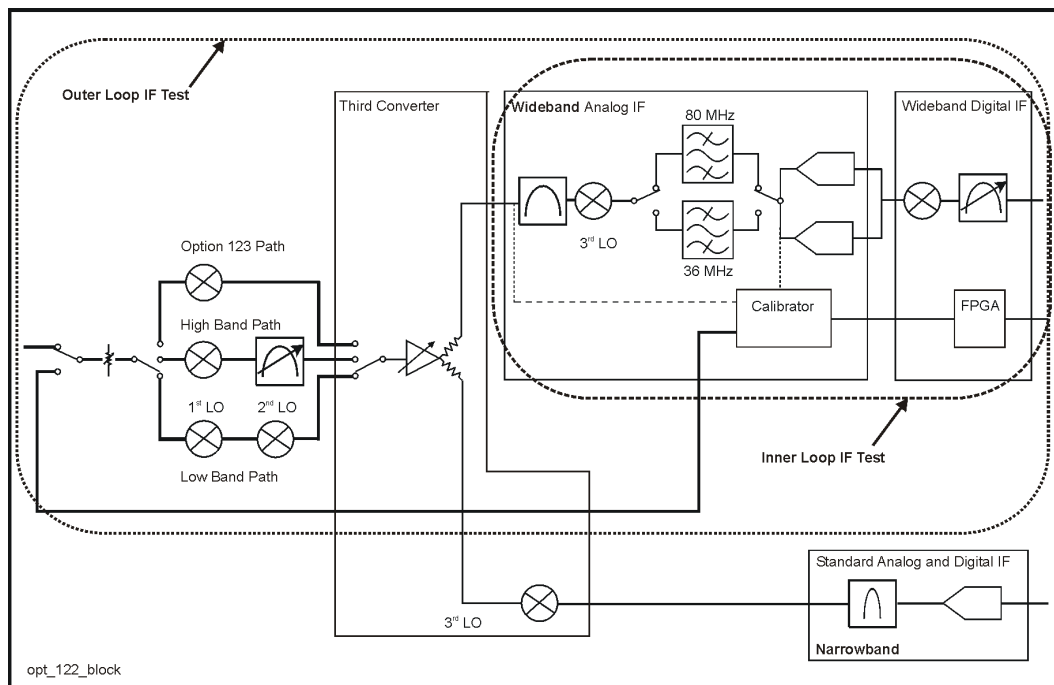
Errors particular to the Wideband path are:

- WB IF ADC Image Align
- WBIF Step Gains
- WBIF IF Frequency Response

Also, the Opt Path RF Gain alignment performs an amplitude check of the Wide Band IF assemblies in addition to the Option 1DS Preamp and the Option B7J electronic attenuator. A failure on this test could be caused by any of these assemblies.

Figure 8-3 shows the Wideband and Narrowband signal paths.

**Figure 8-3 Wideband and Narrowband Signal Paths (Option 122 example)**



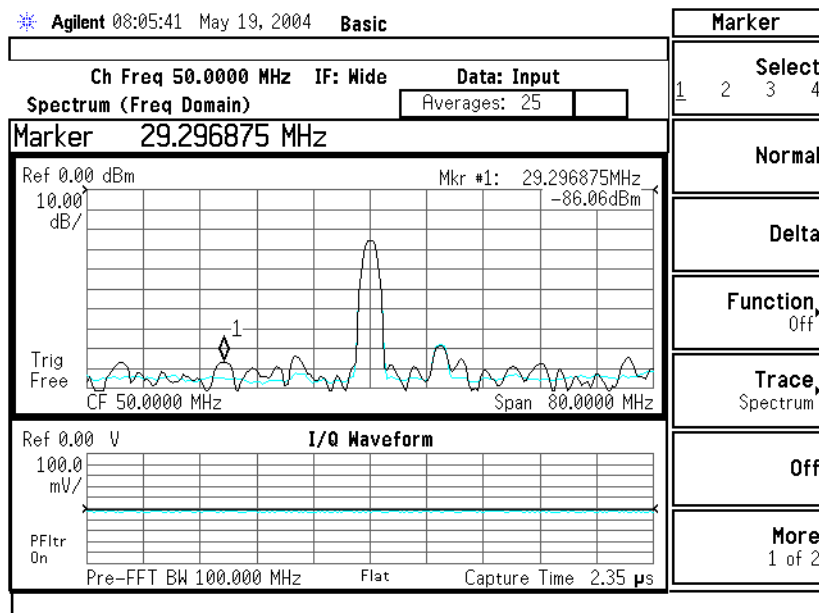
## Setting up the instrument in wideband mode:

The wideband IF is only accessible in the Basic instrument mode.

1. Press **Mode, Basic**
2. Press **Meas Setup, IF Path, Wide**. This selects the wideband IF path through A31 Wideband Analog IF and the A32 Wideband Digital IF assemblies.
3. Press **Input/Output, Input Port, Amptd Ref**.
4. Set **Center Frequency** to 50 MHz.

The internal 50 MHz, -25 dBm calibrator tone should be displayed. The noise floor will be less than -70 dBc. See [Figure 8-4](#).

**Figure 8-4** Noise Floor



If you do not see a signal, or the signal is not the correct amplitude, or the noise floor is incorrect, check the performance in the standard narrow band mode.

**NOTE** Option 122 example shown. The Option 140 span is limited to 40 MHz.

### **Setting up the instrument in narrow band mode:**

Press **Meas Setup, IF Path, Narrow**. This selects the “narrow band” or standard IF Path through the A7 Analog IF and A8 Digital IF assemblies.

The internal 50 MHz, -25 dBm calibrator tone should be displayed. The noise floor will be less than -70 dBc.

If the problem exists in both IF paths, troubleshoot the narrow band path since the instrument defaults to this path after a power cycle, and it is easier to set up.



**If the problem only exists in the wideband path:**

Set up the instrument in wideband mode as documented above.

1. Assure the Wideband Analog IF and Wideband Digital IF assemblies are properly seated.
2. Assure the W60 ribbon cable that connects the Wideband Digital IF to the Wideband Analog IF is connected properly.
3. Verify the 100 MHz and 300 MHz reference signals from the A11 Reference assembly to the Wideband Analog IF are at the correct power level and frequency. See the chart below and the Option 122 block diagram.
4. Verify the signal amplitude and frequency from the A10 3rd Converter. Note that the frequency values are dependent on span and whether the IF Path selected is wide or narrow. For this wideband test, the 3rd Converter output frequency will be 322 MHz for spans  $\leq$  36 MHz, and 300 MHz for spans  $>$  36 MHz.

If the instrument is taken out of wideband mode by selecting **IF Path Narrow**, the output of the 3rd converter will be 321.4 MHz. See the chart below and the Option 122 or 140 block diagram.

	<b>A10 3rd Converter Output to A31 Wideband Analog IF (“40” color cable)</b>	<b>300 MHz In from All Reference Assy (“95” color cable)</b>	<b>100 MHz in from A11 Reference Assy (“65” color cable)</b>
Span $\leq$ 36 MHz	-19 dBm $\pm$ 2 dB at 322 MHz	-1 dBm $\pm$ 2 dB at 300 MHz	-6 dBm $\pm$ 2 dB at 100 MHz
Span $>$ 36 MHz	-20 dBm $\pm$ 2 dB at 300 Mhz	-1 dBm $\pm$ 2 dB at 300 MHz	-6 dBm $\pm$ 2 dB at 100 MHz
When the IF Path is set to Narrow mode	-26 dBm $\pm$ 2 dB at 321.4 MHz	-27 dBm $\pm$ 2 dB at 300 MHz	-6 dBm $\pm$ 2 dB at 100 MHz

If the problem is not fixed, suspect the Wideband Analog IF or the Wideband Digital IF. Perform the procedures that follow.

---

**NOTE** If the problem reported in wideband mode is not seen yet, you must look over the entire bandwidth of the wideband IF path by performing the following procedures.

---

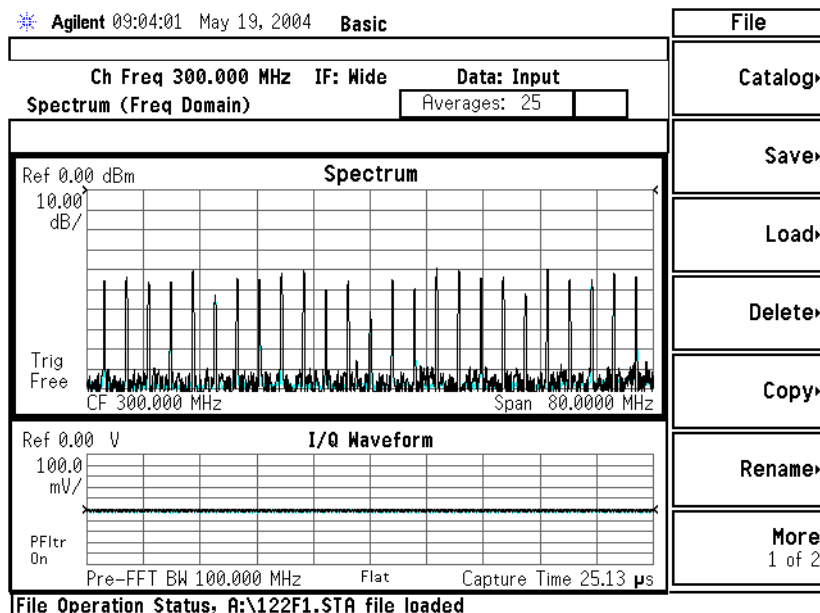
## Viewing the wide band response to a comb signal (inner loop test):

The wideband IF is only accessible in the Basic instrument mode.

1. Press **Mode, Basic**
2. Press **Meas Setup, IF Path, Wide**. This selects the wideband IF path.
3. Press **Input/Output, Input Port, IF Align**.
4. Press **IF Align Signal**.
5. Press **Signal Type** and select **Comb** The comb signal stimulates the entire 80 MHz IF bandwidth (for Option 122) or 40 MHz IF bandwidth (for Option 140).
6. Press **Meas Setup, Res BW** and type in **150kHz**

You will see a display of the internal comb signal that is generated on the A7 Wideband Analog IF assembly and sent through both the Analog IF assembly and the A32 Wide Band Digital IF assemblies. We will call this the inner loop test since it is contained inside the wideband Analog IF and Digital IF assemblies only. Disregarding the center tone, all comb teeth should be within 15 dB of each other, and at least 20 dB above the noise floor. See [Figure 8-5](#) below. Also see the chart on [page 180](#).

**Figure 8-5 Comb Teeth**



## **Viewing the wide band response to a comb signal (outer loop test):**

If the display is correct, you must now inject a comb calibration signal through a larger signal path. The comb signal from A32 Wide Band Digital IF will now be injected into the A14 input attenuator and go through the RF path and the A10 3rd Converter before entering the A31 wideband analog and A32 digital IF assemblies. This is the outer loop test.

Perform the outer loop test as follows:

1. Press **Input/Output, Input Port, WB Align (f=300 MHz)**
2. Press **Frequency**, type in **300 MHz**

You must tune the analyzer to 300 MHz because the WB Align comb signal will now be present at the front end of the instrument.

The displayed comb signal level will decrease about 10 dB referenced to the displayed level of the IF Align signal in the inner loop test. The comb spacing and relative comb amplitudes will remain the same as they were in [Figure 8-5](#).

### Troubleshooting Table

Test Condition	Test Results	Assumptions	Possible Problem	Notes
IF Align signal selected (Inner loop test)	Good	This means the A31 Wide band Analog IF circuits from the point where the calibrator signal is applied are OK. There are a few components on the very front end on the board such as the input connector that are not tested  The 300 MHz and 100 MHz reference signals from the Reference assembly are correct.  The A32 Wideband Digital IF assembly is good		
WB Align signal selected  (Outer loop test)	Bad	The non-wideband signal path (narrow IF path) functions correctly.	A10 Third Converter  The A31 Wideband Analog IF input connector or cal switch or A31 Cal Out connector or cal switch is faulty.  Cable W65 from the 3rd Converter to the A31 input connector.  Cable W64 from the A31 Cal out port to the 3rd Converter faulty.	
IF Align signal selected (Inner loop test)	Bad		The wideband IF Align calibrator is faulty	
WB Align signal selected (Outer loop test)	Good			
IF Align signal selected (Inner loop test)	Bad		A31 Wideband Analog IF assembly faulty	Continue with next step in this procedure
WB Align signal selected (Outer loop test)	Bad		A31 Wideband Analog IF assembly faulty	Continue with next step in this procedure

## Wide Band Analog IF Assembly Filter Path Test

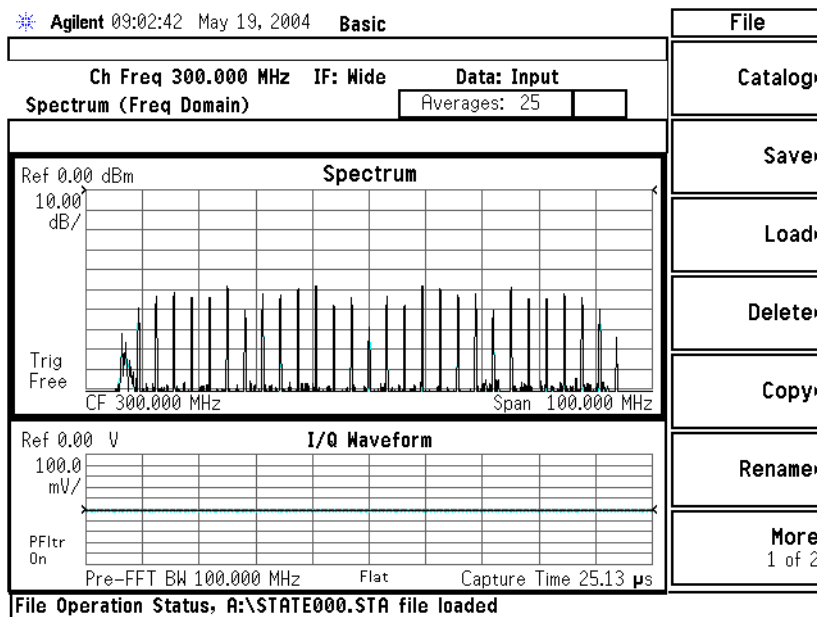
This routine allows you to use the WB Align (f=300 MHz) comb cal signal to view the filter response of the 80 MHz filter path and the 36 MHz filter paths. Also the ADC dither signal response can be seen allowing you to determine if the dither signal is present.

The following diagnostic routine requires entering the password protected Service menus.

1. Press **System More, More Service**
2. Enter the service password **-49** and press **Enter**
3. **Service**
4. **Meas Setup**
5. **Wide Band Setup**
6. **Wide Band Advanced, More**
7. **All Freq Pts On**
8. **Span 100 MHz**
9. **RBW 150 kHz**

The PSA display now shows the filter response of the 80 MHz filter path in the Wideband Analog IF assembly. The Dither signal can be seen on the far left hand side of the filter response. See [Figure 8-6](#).

**Figure 8-6** 80 MHz Filter Response



10. Press **Return**

11. Press **WB ADC Dither** and turn the dither signal **On** and **Off** to view the effect of turning dither on and off.

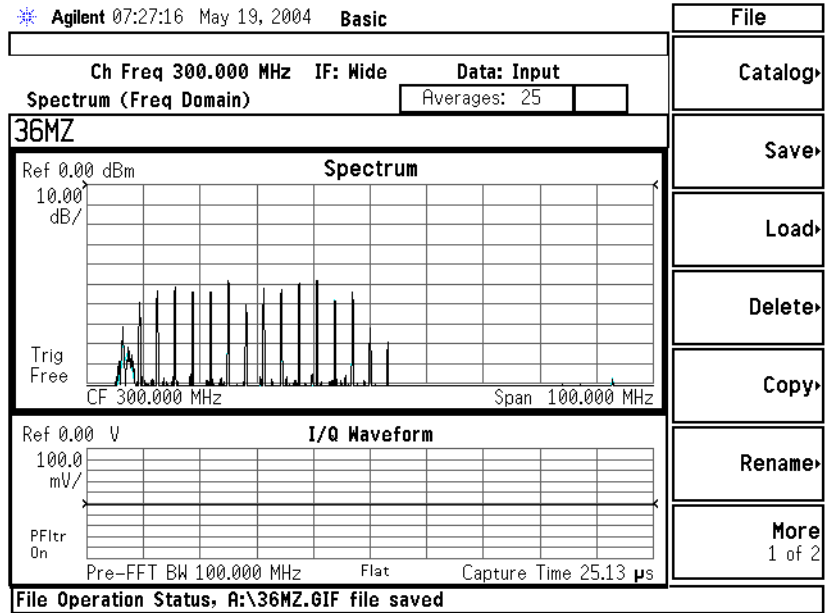
12. Press **Analog Filter**

13. Select **Narrow 36 MHz**

The PSA display now shows the filter response of the 36 MHz filter path in the Wideband Analog IF assembly. See [Figure 8-7](#).

**Figure 8-7**

**36 MHz Filter Response**



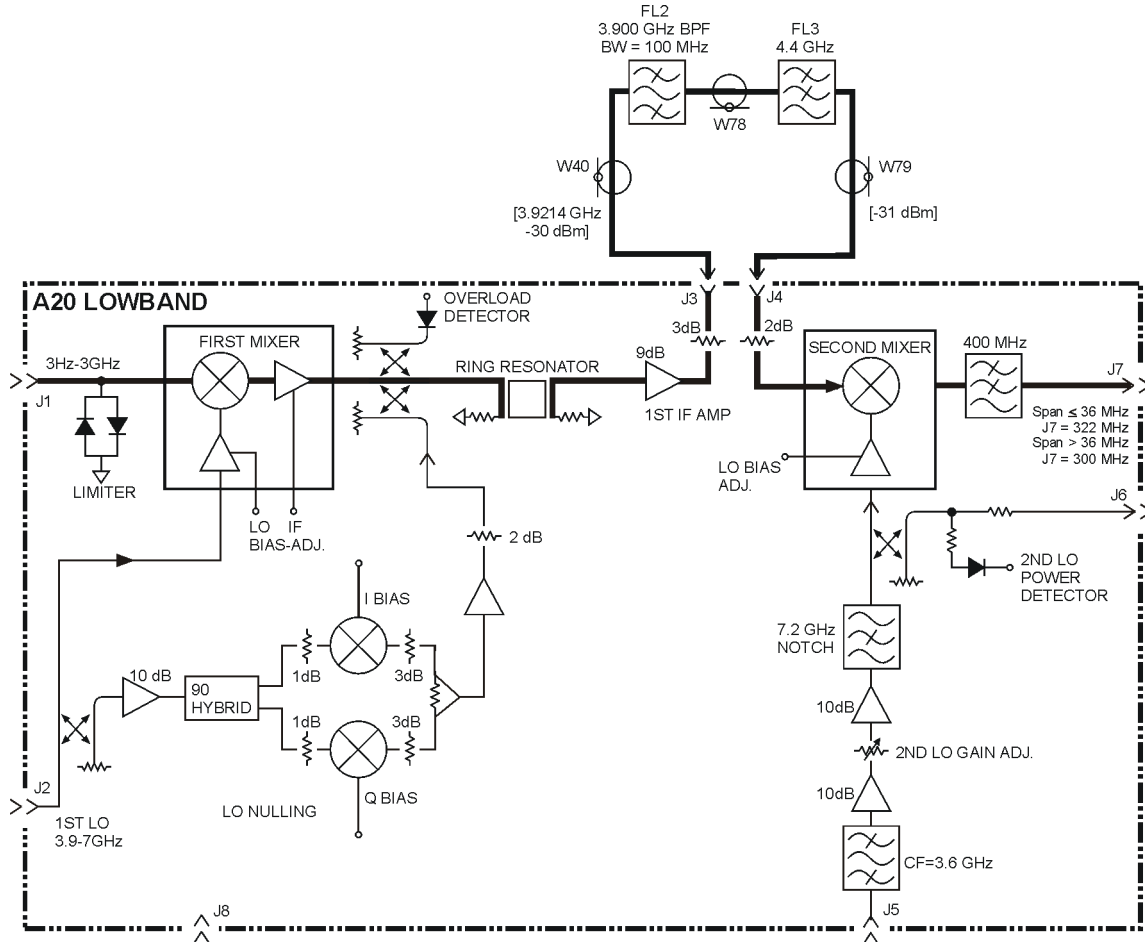
If the response of only one of the filter paths is incorrect, the problem is isolated to that filter path on the A31, Wideband Analog IF assembly.

## Option 122 or 140 Lowband Filters

Figure 8-8 shows FL2, FL3, and associated cables. FL2 on Option 122 or 140 units is a 100 MHz BW filter. Non-Option 122/140 units have 40 MHz BW filters.

FL3 is added to suppress spurious responses since FL2 has such a wide bandwidth.

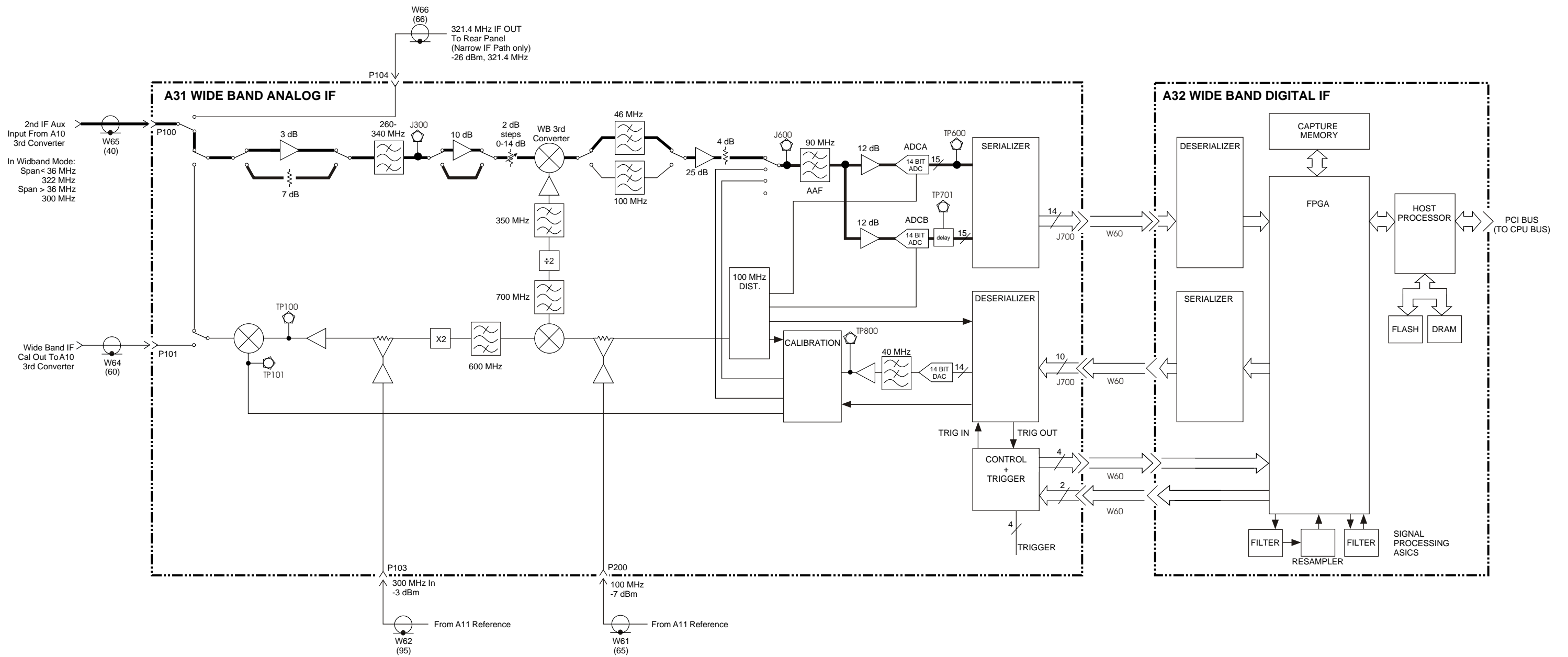
**Figure 8-8** Option 122 Lowband Filters



Hardware Options

**Verifying Option 122 or 140, Wide Bandwidth Digitizer**





**OPTION 122 or 140**  
**A31/A32 WIDE BAND IF BLOCK DIAGRAM**  
 March 28, 2008

Hardware Options  
**Verifying Option 122 or 140, Wide Bandwidth Digitizer**

## **Overview and Verification of Option 123, Microwave and Millimeter Preselector Bypass**

### **Overview of Option 123 in the E4440A, E4443A, or E4445A**

Option 123 provides an unpreselected input mixer path for the E4440A, E4443A and E4445A spectrum analyzers in the 3.05 to 26.5 GHz frequency range. This allows a signal path with a wider bandwidth and less amplitude variability, which is an advantage when doing modulation analysis and broadband signal analysis. The disadvantage is that, without the preselector, image signals will appear.

#### **Functionality**

In normal instrument operation, when operating above 3.05 GHz, a preselector precedes the input mixer (see [Figure 8-9](#) below). This preselector is part of the RYTHM circuitry, and is basically a tunable bandpass filter which prevents signals away from the frequency of interest from combining in the mixer to generate in-band spurious signals. The consequences of using this preselector filter are its limited bandwidth, amplitude and phase ripple in its passband, and amplitude and phase instability due to center frequency drift. With Option 123, the RF path can be routed via RF switches to an alternate highband (3.05 - 26.5 GHz) mixer that does not incorporate the tunable bandpass filter.

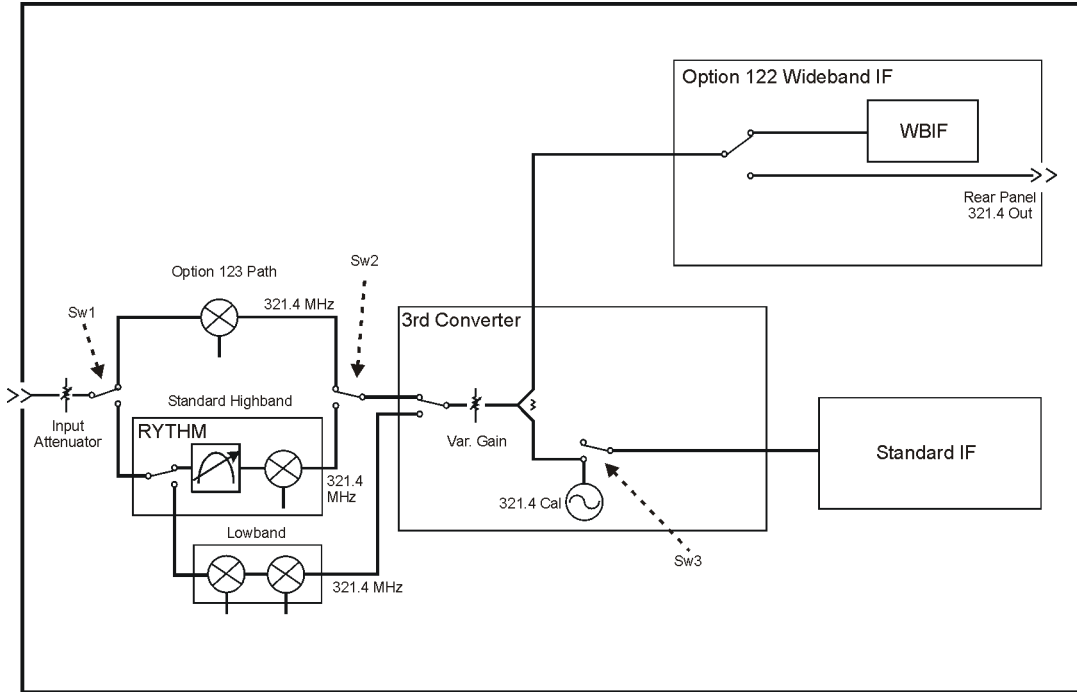
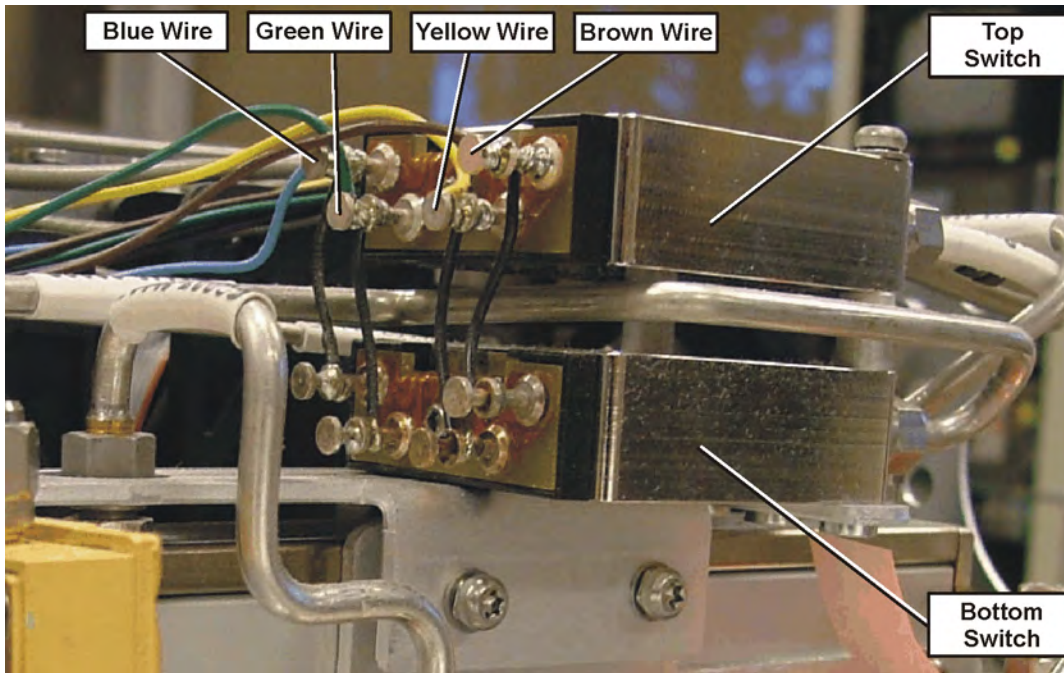
**Figure 8-9**      **Block Diagram for DC to 26.5 GHz Option 123 Instruments**

Figure 8-9 shows the block diagram of the instrument with an upper frequency of 26.5 GHz. Functionally, Option 123 adds two new switches (Sw1 and Sw2) into the signal path plus an additional mixer. In normal operation above 3.05 GHz, Sw1 and Sw2 are in their down position, which selects the signal path through the preselection filter. When the unpreselected path is chosen, Sw1 and Sw2 are changed to their up position, which bypasses the preselection filter.

When the instrument is operating below 3.05 GHz (Band 0), the signal is routed to the Lowband circuitry. The lowband circuitry has built-in low pass filtering so it does not require preselection. Please note that the Lowband (Band 0) path is unavailable when switches Sw1 and Sw2 are configured for unpreselected operation. Furthermore, since these are mechanical switches, it is unacceptable to switch them in the middle of a sweep. Therefore when the unpreselected path is chosen, Band 0 is locked out, and when any part of the sweep is in Band 0, the unpreselected path is locked out.

The 3rd converter board in the instrument contains a splitter that is used route the 321.4 MHz IF signal to the normal digital IF and also, out the 321.4 MHz IF Out connector on the instrument's rear panel. If Option 122 (80 MHz Bandwidth Digitizer) is installed, the second path from the splitter is first routed to the Option 122 Analog IF board where a switch is used to route the IF signal through the Option 122 Analog IF or to the rear panel 321.4 MHz IF Out. In order to obtain a clean signal on the 321.4 MHz IF Out port, the 3rd converter calibrator switch (Sw3 in figure 1) must be thrown into its down position. If Sw3 is in its up position, the 321.4 MHz IF is still present on the rear panel but it is corrupted by frequency response ripples caused by the analyzer through path circuits. Option 123 provides the ability to control the 321.4 MHz IF routing so that a clean signal can be obtained out the rear panel, although no signal will be present on the analyzer's display. To manually control this routing, press the Input/Output key and use the 321.4 MHz IF Out Opt softkey to switch between the rear panel Dnconverter WBIF or the spectrum analyzer (SA) signal path. The rear panel 321.4 MHz IF Out path is called Dnconverter WBIF because it is usually used when using the instrument as a down converter where wide BW is required.

**Figure 8-10**      **Option 123 Switch Wiring**

Wire Color	Voltage
Blue	25 Vdc, Steady state. Preselector Off to On transition should show a negative-going pulse for approximately 18 ms, then the 25 Vdc steady state
Green	25 Vdc supply
Yellow	25 Vdc supply
Brown	25 Vdc, Steady state. Preselector On to Off transition should show a negative-going pulse for approximately 18 ms, then the 25 Vdc steady state

Switches are actuated using a pulse drive. The pulse duration must be at least 15 ms to ensure that the switch will fully latch.

The blue and brown wires provide the pulse drive to the switch.

### Verifying Option 123, Microwave Preselector Bypass (E4440A/E4443A/E4445A)

The following test switches in and out the preselector bypass path while viewing a signal. There may be slight amplitude differences between the two signal paths.

**Table 8-1**

#### Required Equipment

Description	Recommended Model
Signal Source > 4 GHz	83630B
High quality, low-loss cable, 3.5 mm (2 required)	8120-4921
Adapter, N (m) to 3.5 mm (f)	1250-1744
Adapter, 3.5 mm (f) to 3.5 mm (f)	83059B

1. Preset the PSA and signal source.
2. Connect the signal source to the PSA RF input with a high quality low-loss cable.

PSA Settings	
Mode	Spectrum Analysis
Center Frequency	4 GHz
Start Frequency	3.06 GHz
Stop Frequency	10 GHz
Signal Source Settings	
Frequency	4 GHz
Amplitude	-10 dBm

3. The 4 GHz signal should appear on screen. The analyzer is currently using the preselected path.
4. On the PSA, Press **Input / Output, Microwave Preselector OFF**. You should have heard the switches “click”. The preselector is now bypassed.

The 4 GHz signal will still be present, however the display may show many other responses. This occurs because the preselector filter that eliminates input frequencies that cause these images, multiples, and out-of-band responses; has been bypassed by the Option 123 hardware.

You may also notice a step in the noise floor at the 6.6 GHz bandcrossing. This is normal performance of the Option123

highband mixer. Steps will also appear at 13.2 GHz and 19.2 GHz.

5. Tune the source and PSA to 10 GHz, 15 GHz, and 20 GHz and check the signal level. The accuracy of the measurement will depend on the source flatness, the quality of the interconnect cable, and the frequency response of the PSA.
6. See the foldout block diagram Option 123 (E44440A, 43A, 45A) for signal level troubleshooting.











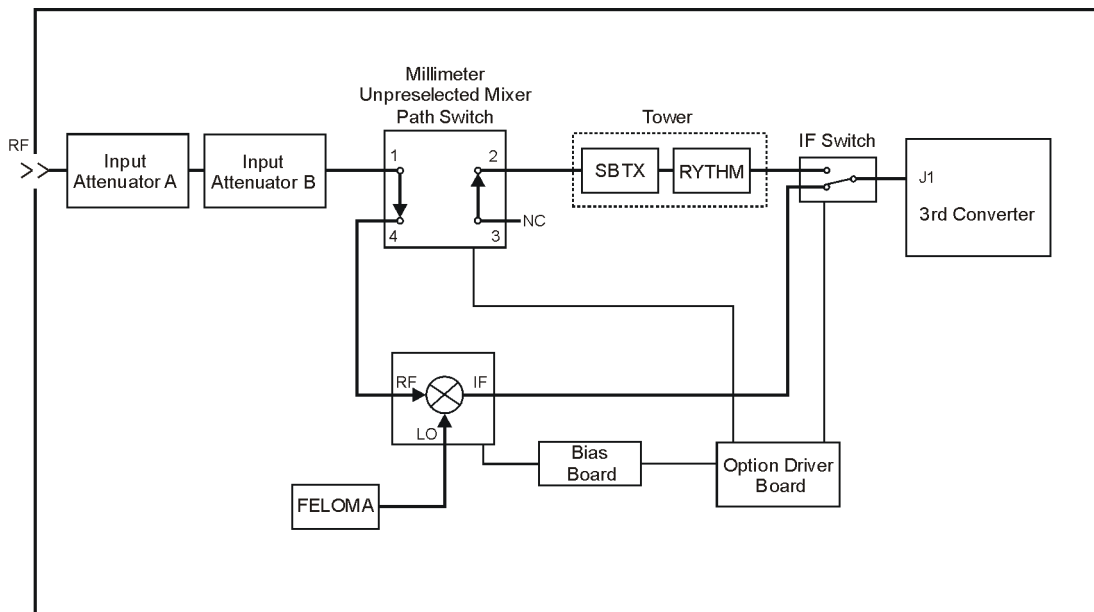
## Overview of Option 123 in the E4446A, E4447A, or E4448A

### Functionality

During normal operation of the PSA, when operating above 3 GHz, a preselector precedes the input mixer. This preselector is part of the SBTX and RYTHM circuitry. It is basically a tunable bandpass filter which prevents signals away from the frequency of interest from combining in the mixer to generate in-band spurious signals. The consequences of using this preselector filter are its limited bandwidth, amplitude and phase ripple in its passband, and amplitude and phase instability due to center frequency drift.

Option 123 adds the > 3.05 GHz to 50 GHz unpreselected highband mixer path to the E4446A, E4447A, and E4448A millimeter wave band instruments. The block diagram is shown in Figure 8-11. This option adds the millimeter unpreselected mixer, the 50 GHz coax transfer switch and the coax IF switch. The option driver board provides control of the switches, the unpreselected bias board control, and storage for the calibration factors that compensate the unpreselected path flatness.

**Figure 8-11** Block Diagram for 50 GHz Option 123 Instruments

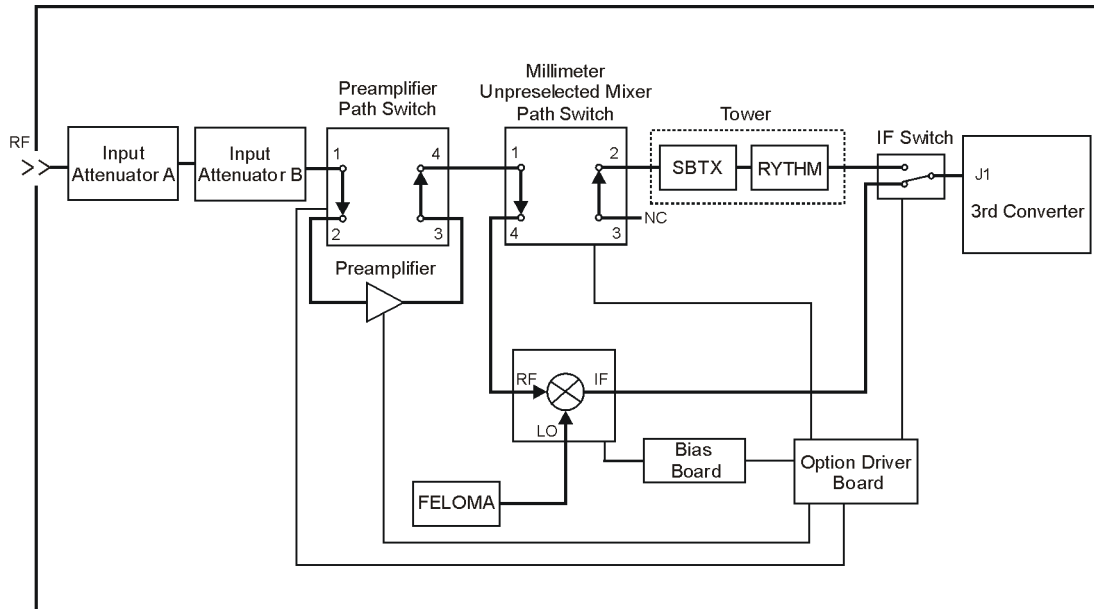


After the RF input attenuators the RF path is either routed to the normal preselected path (through SBTX and RYTHM) or to the unpreselected path using the coax transfer switch. The unpreselected mixer uses the ~3 to 7 GHz LO from the LO output port of the LO Multiplying Amplifier (referred to as FELOMA elsewhere). Since the LO normally used for the external mixing bands is used for the unpreselected mixer, Option AYZ (External Mixing) is not compatible with Option 123.

Since the E4446A, E4447A, and E4448A instruments contain an additional down conversion path, with its own preselection filter, Option 123 for these models will bypass both sets of preselection filters present in those instruments i.e. the microwave preselection filter as well as the millimeter wave preselection filter.

Figure 8-12 shows the block diagram for a configuration that has both the Preamp Option 110 as well as the Unpreselected Path Option 123.

**Figure 8-12**      **Block Diagram for 50 GHz Option 110 and 123 Instruments**



### Verifying Option 123, Microwave Preselector Bypass (E4446A/E4447A/E448A)

The following test switches in and out the preselector bypass path while viewing a signal. There may be slight amplitude differences between the two signal paths.

**Table 8-2**

#### Required Equipment

Description	Recommended Model
Signal Source > 4 GHz	83630B
High quality, low-loss cable, 2.4 mm	8120-6164
various adapters depending on signal source used	

1. Preset the PSA and signal source.
2. Connect the signal source to the PSA RF input with a high quality low-loss cable.

PSA Settings	
Mode	Spectrum Analysis
Center Frequency	4 GHz
Start Frequency	3.06 GHz
Stop Frequency	10 GHz
Signal Source Settings	
Frequency	4 GHz
Amplitude	-10 dBm

3. The 4 GHz signal should appear on screen. The analyzer is currently using the preselected path.
4. On the PSA, Press **Input / Output, Uw/mmW Preselectors OFF**. You should have heard the switches click. The preselectors are now bypassed.
5. Tune the Source and PSA to 10 GHz, 15 GHz, 20 GHz, 30 GHz, 40 GHz and 50 GHz to determine if any problems exist in other frequency bands. The accuracy of the measured amplitude will depend on the source flatness, quality of interconnect cables, and the frequency response of the PSA. You may wish to select **uW/mmW Preselectors On** and run through the test frequencies so you can compare both the preselector on and off amplitude values so you can separate the amplitude variation of the preselector off state from the test equipment and preselector on signal path contributions.

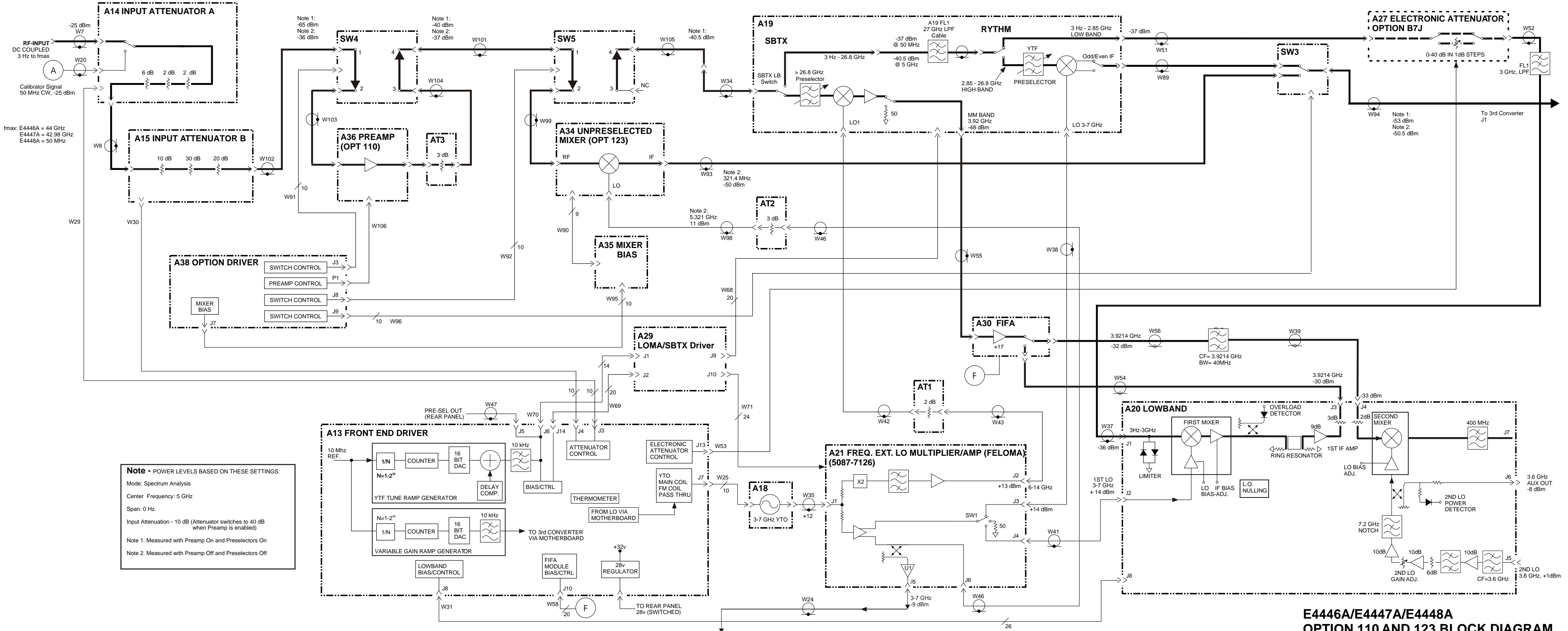
## Troubleshooting Hints

1. Place the instrument on a table. Remove the screws that hold the instrument front frame to the chassis so the front frame can be dropped to expose the circuitry behind the front frame. Refer to the instructions for dropping the front frame on [page 314](#). Do not remove and front panel cables since the front frame must remain functional.
2. Run **Align All Now**, then turn **Auto Align OFF**. This will allow you to remove cables and troubleshoot without having Auto Align run unexpectedly and change your measured results.
3. Signal path troubleshooting requires connection to devices with 2.4 mm connectors. A short semi-rigid cable with 2.4 mm male connectors on both ends is recommended. The Required Test Equipment list on [page 24](#) contains the Agilent part number of a cable that can be modified (bent) and used for this purpose.
4. Other items required include:
  - TORX #10 driver
  - 5/16-inch wrenches (2 required)
  - 1/4-inch wrench
  - Cable, 2.4 mm (m) to 2.4 mm (m) or (f), 1 meter (2 required)
  - assorted 2.4 mm adapters

Refer to the E4446A, 47A, 48A Option 110 and Option 123 block diagram for interconnection and signal level information.



# E4446A/E4447A/E4448A OPTION 110 AND 123 BLOCK DIAGRAM



**E4446A/E4447A/E4448A  
 OPTION 110 AND 123 BLOCK DIAGRAM  
 January 30, 2006**



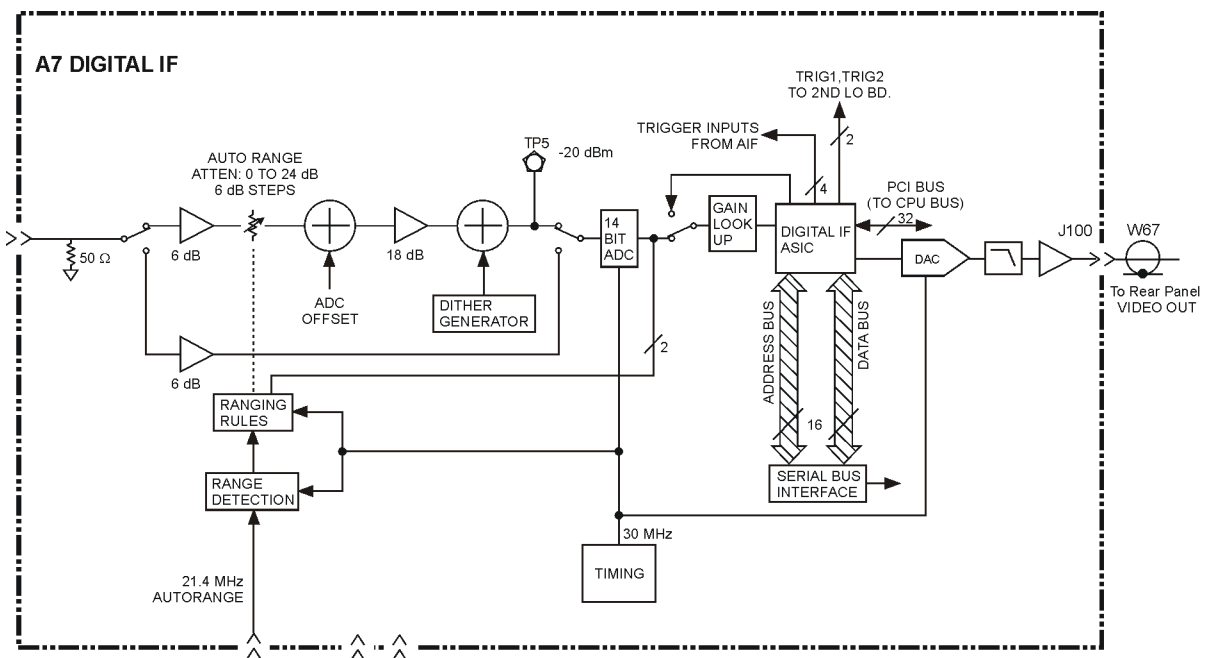
## Verifying Option 124, Y-Axis Video Out

The following two procedures outline how to verify that the rear panel video out signal is correct. The first procedure is a quick check of the 0 to 1 V video out signal level that requires only a voltmeter.

The second procedure allows you to view the video out signal on an oscilloscope and compare it to the PSA screen.

Figure 8-13 shows the block diagram of the optional A7 Digital IF that supports Option 124.

Figure 8-13 Option 124



### Procedure 1 - Quick check of video out level.

Connect a voltmeter to the rear panel Video Out port of the PSA. Set the voltmeter to measure DC volts.

1. With the instrument is spectrum analysis mode, **Preset** the instrument.
2. Select the internal amplitude reference by pressing **Input/Output**, **Input Port**, and selecting the **Amptd Ref**.
3. Tune the analyzer to 50 MHz. **Frequency**, 50 MHz.
4. Set the analyzer to 5 dB/div. **Amplitude**, **Scale/Div**, 5 dB
5. Set the analyzer to zero span. **Span**, **Zero Span**.

6. Place the displayed signal at mid screen by pressing **Amplitude**, and adjusting the reference level until the signal is as close as possible to exactly mid screen. The voltmeter should read 0.5 volts.
7. Adjust the reference level to place the signal exactly on the top graticule line. The voltmeter should read 1 V.

---

**NOTE**

The signal trace cannot be displayed above the top graticule line. However, the analyzer will measure signals above the top graticule line. Therefore the Video Output will be driven above 1 V even though it appears the on screen trace is only at the top graticule line.

---

8. Adjust the reference level to place the signal on the bottom graticule line. The voltmeter should read 0V.
9. Notice also that as the signal is moved up and down the screen, the voltmeter reading changes 0.1V per graticule division.

## Procedure 2 - Detailed view of the video signal

Connect channel 1 of the oscilloscope to the rear panel Video Out port of the PSA.

Connect channel 2 of the oscilloscope to the rear panel Trigger 1 Out port of the PSA. Trigger 1 on the PSA is the High=Sweeping (HSWP) signal. Trigger 1 goes high just before the sweep starts on the analyzer screen. These connections will allow the oscilloscope display to resemble the PSA display.

### PSA Setup:

Instrument preset		
Turn on internal 50 MHz, -25 dBm cal signal		
Center Frequency	50 MHz	
Span	10 MHz	
Sweep Time	1 ms	
Res BW	300 kHz	
Attenuator	10 dB	
Ref Level	-24 dBm	Places the 50 MHz cal signal at top screen on the PSA
Scale/Div	10 dB/ Div	

**Oscilloscope Setup:**

Input 1	Turn on the input. 1 M ohms, DC Coupling, BW limit OFF Probe = 1	This input connected to PSA Video Out
Input 2	Turn on the input. 1 M ohms, DC Coupling, BW limit OFF Probe = 1 Invert = Off	This input connected to Trigger 1 Out of PSA.  Displaying the external trigger signal shows the relationship between the trigger signal and the displayed video on the oscilloscope.
Time/Div	200 ms	
Volts/Div	200 mv	
Trigger Source	Input 2	
Trigger Mode	Normal	
Trigger Level	Set so oscilloscope triggers	

The oscilloscope display reveals the following:

The Video Out signal resembles the PSA display. This means the A7 Digital IF assembly in the PSA has successfully reconstructed a video signal from the ADC.

The period of the trigger signal is 1 ms which corresponds to the full 10 division horizontal sweep time of 1 ms on the PSA.

The 200 mv /Div vertical scope setting allows 5 vertical divisions on the oscilloscope to correspond to the 10 division display on the PSA.



---

## **9** **Block Diagrams**

## What You Will Find in This Chapter

The following information is presented in this chapter:

1. A table showing signal levels in the instrument's forward path.
2. Descriptions of the signal mnemonics used in the instrument and mnemonic pin locations.
3. Overall block diagrams of the Agilent PSA Series Spectrum Analyzers.

The following sections are found in this chapter:

- Mnemonics Descriptions.....page 209
- Overall block diagram (E4440A, E4443A, E4445A).....page 213
- Front Panel Interface Board block diagram .....page 215
- Motherboard Schematic .....page 217
- Overall block diagram (E4446A, E4448A).....page 219



## Signal Mnemonics

Faulty assemblies can be identified by confirming that a specific signal on an assembly is not at its expected level.

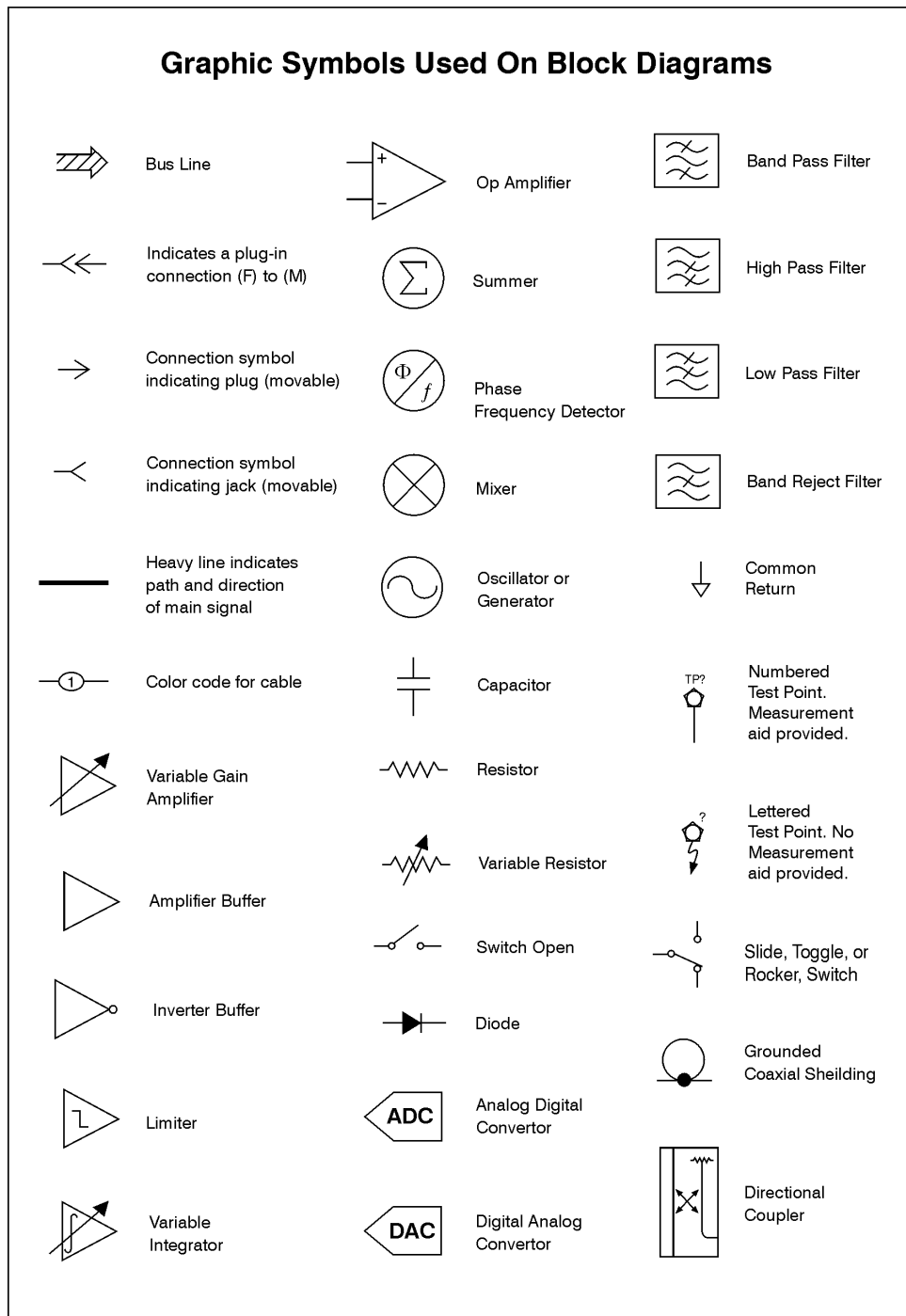
**Table 9-1 Mnemonic Descriptions**

Mnemonic	Description
ACOM	Analog ground (chassis)
CALOSC_H	Differential ECL 21.4 MHz calibration oscillator output from the analog IF board to the RF board
CALOSC_L	Differential ECL 21.4 MHz calibration oscillator output from the analog IF board to the RF board
DCOM	Digital ground (single point ground inside the power supply)
FP_BLUE0	Flat panel display blue 0 (LSB) signal from the CPU board to the front panel interface board
FP_BLUE1	Flat panel display blue 1 signal from the CPU board to the front panel interface board
FP_BLUE2	Flat panel display blue 2 signal from the CPU board to the front panel interface board
FP_BLUE3	Flat panel display blue 3 (MSB) signal from the CPU board to the front panel interface board
FP_CBLANKL	Flat panel display blanking signal from the CPU board to the front panel interface board
FP_CLK	Front panel bus 7.5 MHz clock signal from the CPU board to the front panel interface board
FP_CSL	Front panel bus chip select signal from the CPU board to the front panel interface board
FP_D0	Front panel bus data 0 (LSB) signal from the CPU board to the front panel interface board
FP_D1	Front panel bus data 1 signal from the CPU board to the front panel interface board
FP_D2	Front panel bus data 2 signal from the CPU board to the front panel interface board
FP_D3	Front panel bus data 3 signal from the CPU board to the front panel interface board
FP_D4	Front panel bus data 4 signal from the CPU board to the front panel interface board
FP_D5	Front panel bus data 5 signal from the CPU board to the front panel interface board
FP_D6	Front panel bus data 6 signal from the CPU board to the front panel interface board
FP_D7	Front panel bus data 7 (MSB) signal from the CPU board to the front panel interface board
FP_DOTCLK	Flat panel display 25 MHz dot clock signal from the CPU board to the front panel interface board
FP_GREEN0	Flat panel display green 0 (LSB) signal from the CPU board to the front panel interface board
FP_GREEN1	Flat panel display green 1 signal from the CPU board to the front panel interface board
FP_GREEN2	Flat panel display green 2 signal from the CPU board to the front panel interface board
FP_GREEN3	Flat panel display green 3 (MSB) signal from the CPU board to the front panel interface board
FP_HSYNCL	Flat panel display horizontal sync signal from the CPU board to the front panel interface board
FP_P15SBY	Front panel +15V standby power supply from the fan control board to the front panel interface board
FP_PWR_RST_L	Front panel bus power on reset signal from the CPU board to the front panel interface board
FP_RED0	Flat panel display red 0 (LSB) signal from the CPU board to the front panel interface board

**Table 9-1 Mnemonic Descriptions**

Mnemonic	Description
FP_RED1	Flat panel display red 1 signal from the CPU board to the front panel interface board
FP_RED2	Flat panel display red 2 signal from the CPU board to the front panel interface board
FP_RED3	Flat panel display red 3 (MSB) signal from the CPU board to the front panel interface board
FP_VSYNCL	Flat panel display vertical sync signal from the CPU board to the front panel interface board
FP_W_RL	Front panel bus read/write signal from the CPU board to the front panel interface board
GATE_ARM	Gate arm signal from the analog IF board to the digital IF board
GATE_TRIG	Gate trigger signal from the analog IF board to the digital IF board
HPUP	High = power up +5.2 V when instrument is turned on
N12	-12 V power supply from the motherboard to the CPU board
N15	-15 V power supply on the motherboard
N5.2	-5.2 V power supply on the motherboard
P12	+12 V power supply from the motherboard to the CPU board
P15	+15 V power supply on the motherboard
P15SBY	+15 V standby power supply on the motherboard
P32	+32 V power supply on the motherboard
P5.2	+5.2 V power supply on the motherboard
PROBE_N12.6	Probe power -12.6 V power supply from the fan control board to the front panel interface board
PROBE_P15	Probe power +15 V power supply from the fan control board to the front panel interface board
SR_H	Differential ECL sample rate clock from the analog IF board to the digital IF board
SR_L	Differential ECL sample rate clock from the analog IF board to the digital IF board
SWEEP_ARM	Sweep arm signal from the analog IF board to the digital IF board
SWEEP_TRIG	Sweep trigger signal from the analog IF board to the digital IF board
TRIG1	Trigger #1 output from the digital IF assembly to all vertical assemblies
TRIG2	Trigger #2 output from the digital IF assembly to all vertical assemblies
VCC	+5.2 V digital power supply
VDL	+3.4 V digital power supply
VFAN+	Cooling fans positive power supply from the fan control board to the fan connectors on the motherboard
VFAN-	Cooling fans negative power supply from the fan control board to the fan connectors on the motherboard

Figure 9-1 Graphic Symbols

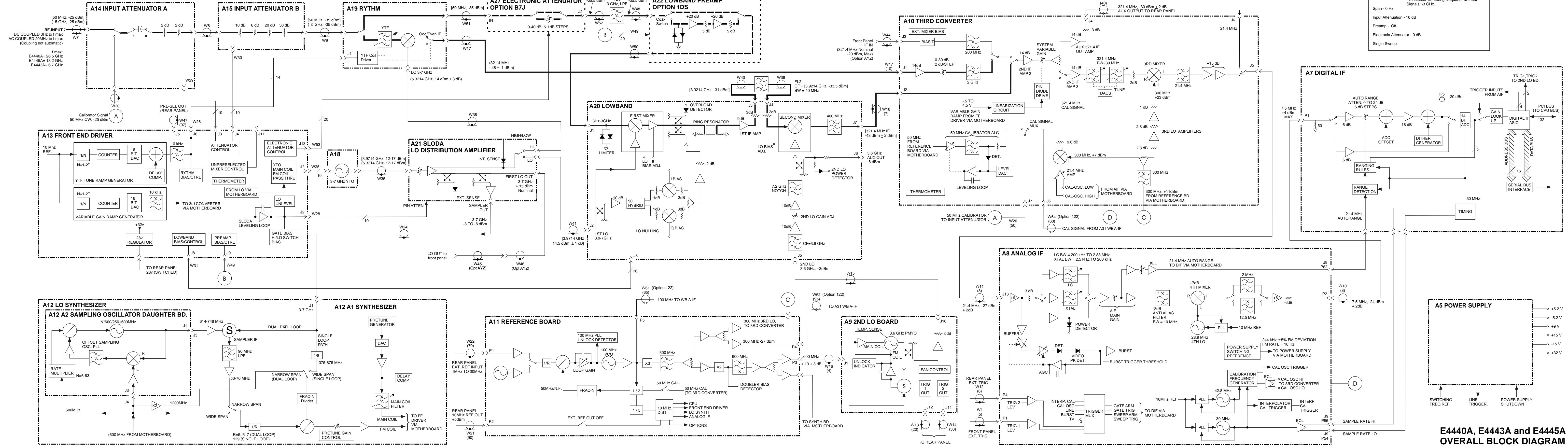


sa83a

---

## Overall Block Diagrams

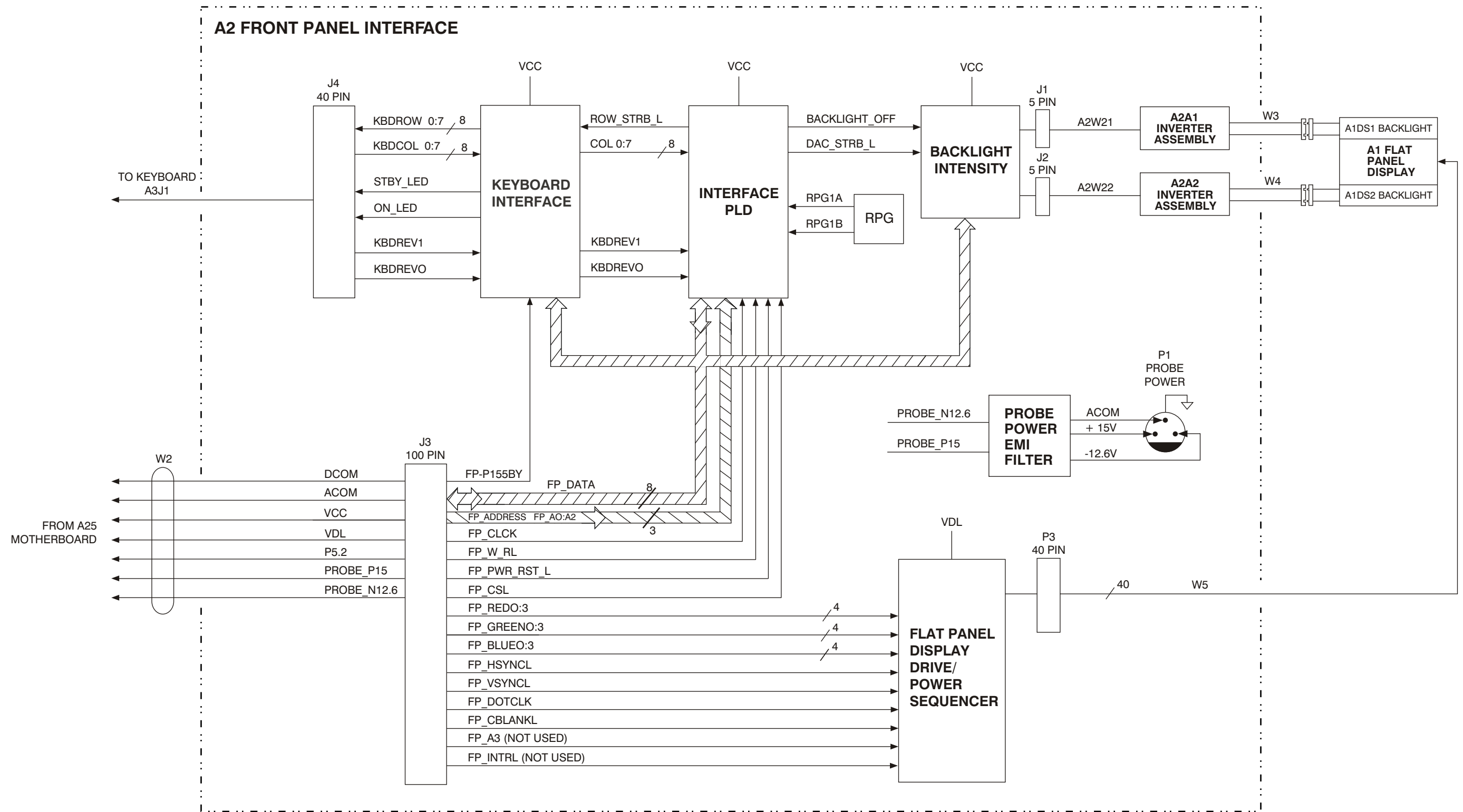
# E4440A, E4443A and E4445A OVERALL BLOCK DIAGRAM



**E4440A, E4443A and E4445A OVERALL BLOCK DIAGRAM**  
 March 28, 2008

Block Diagrams  
**Overall Block Diagrams**

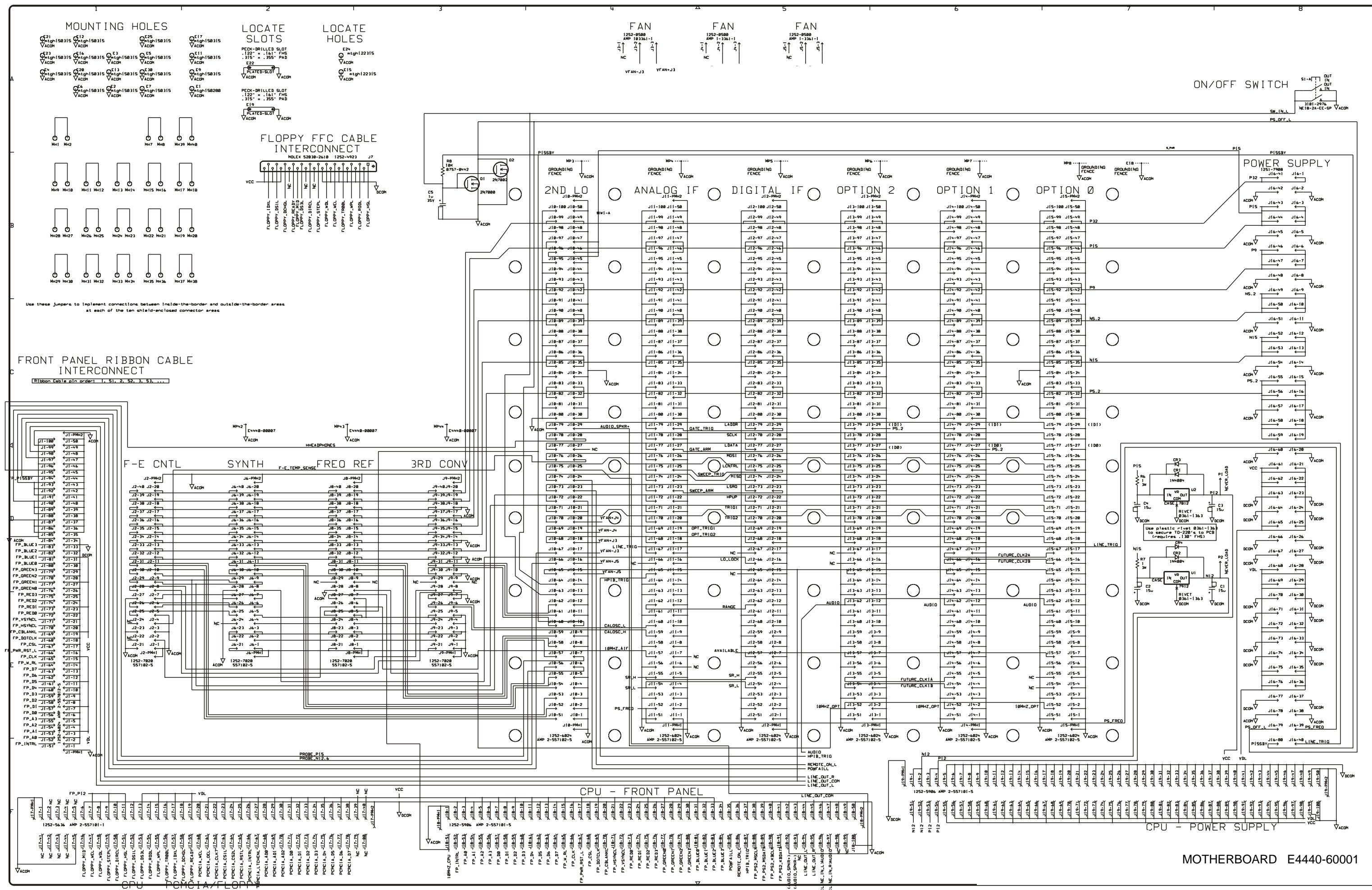
# PSA SERIES FRONT PANEL INTERFACE BLOCK DIAGRAM



PSA SERIES FRONT PANEL INTERFACE BLOCK DIAGRAM



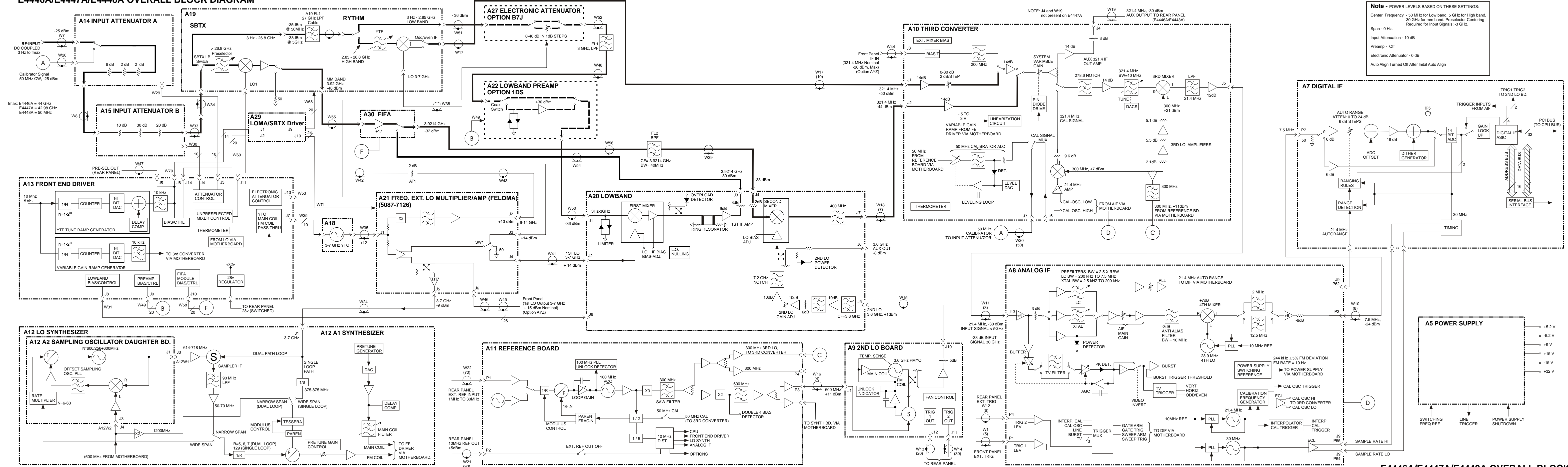




MOTHERBOARD E4440-60001

Block Diagrams  
**Overall Block Diagrams**

**E4446A/E4447A/E4448A OVERALL BLOCK DIAGRAM**



**E4446A/E4447A/E4448A OVERALL BLOCK DIAGRAM**  
 March 28, 2008



---

---

**10**

**Replaceable Parts Lists and  
Locations**

## What You Will Find in This Chapter

The following information is found in this chapter:

1. Part number tables for assemblies, mechanical parts, cables, front panel connectors, and labels.
2. Part location diagrams for the following:

Fig. 10-1 External Hardware	page 249
Fig. 10-2 Top Brace Hardware	page 250
Fig. 10-3 Front Frame Hardware	page 251
Fig. 10-4 Major Assemblies	page 252
Fig. 10-5 RF Section E4440A, E4443A, E4445A - Standard	page 254
Fig. 10-6 YTO Assembly	page 256
Fig. 10-7 RF Input Connector E4440A, E4443A, E4445A	page 258
Fig. 10-8 RF Section Cables E4440A, E4443A, E4445A - Standard	page 260
Fig. 10-9 RF Section and Cables E4440A, E4443A, E4445A - (Options 1DS, BAB, B7J, and AYZ)	page 262
Fig. 10-10 Option 122 or 140 RF Cable Locations	page 262
Fig. 10-11 E4440A, E4443A, E4445A Option 123 Assemblies and Cable Locations	page 264
Fig. 10-12 E4440A, E4443A, E4445A Option 123 Assemblies and Cable Locations	page 264
Fig. 10-13 E4440A, E4443A, E4445A - Option 110 (with Option 123)	page 266
Fig. 10-14 RF Section E4446A, E4447A, E4448A - Standard	page 268
Fig. 10-15 Options 110 and 123 E4446A, E4447A, E4448A	page 270
Fig. 10-16 Options 110 and 123 E4446A, E4447A, E4448A (Rear View)	page 272
Fig. 10-17 RF Input Connector and Attenuators E4446A, E4447A, E4448A	page 274
Fig. 10-18 RF Section Cable Locations E4446A, E4447A, E4448A - Standard	page 276
Fig. 10-19 SBTX Driver Board Ribbon Cable Locations E4446A, E4447A, E4448A	page 278
Fig. 10-20 RF Section Assembly and Cable Locations E4446A, E4447A, E4448A - (Options 1DS, B7J, and AYZ)	page 280
Fig. 10-21 Vertical Board Assembly Cables	page 282

Fig. 10-22 Option Driver Board and Cables	page 284
Fig. 10-23 Option 122 or 140 Assembly and Cable Locations, and Option 124 W67 Cable Location	page 286
Fig. 10-25 Cable Locations, Front End Driver E4440A, E4443A, E4445A	page 290
Fig. 10-26 Cable Locations, Front End Driver E4446A, E4447A, E4448A	page 291
Fig. 10-27 Front Panel Parts	page 292
Fig. 10-28 Front Panel Shield Hardware	page 294
Fig. 10-29 Front Panel Assemblies	page 295
Fig. 10-30 Display Parts	page 296
Fig. 10-31 Disk Drive Parts	page 297
Fig. 10-32 Rear Frame Hardware	page 298
Fig. 10-33 Mid Web Parts	page 300
Fig. 10-34 Fan Guard	page 300
Fig. 10-35 Cable Hold Down	page 302
Fig. 10-36 CPU Parts	page 303

## Replaceable Parts

Some of the assemblies listed in the following table are related to options that are available with the PSA Series Spectrum Analyzers. These options are described below.

Option AYZ	Adds external mixing (E4440A, E4446A, E4447A, E4448A)
Option BAB	Adds APC 3.5 input connector (E4440A only).
Option B7J	Adds digital demod hardware.
Option H70	Adds 70 MHz IF output at the rear panel.
Option 1DS	Adds a 100 kHz - 3 GHz preamplifier.
Option 107	Adds Audio Input.
Option 110	Adds a 10 MHz - 26.5 GHz Preamplifier (E4440A, E4443A, E4445A) or a 10 MHz - 50.0 GHz Preamplifier (E4446A, E4447A, E4448A)
Option 111	Adds USB Device side I/O.
Option 115	Adds Extended Memory.
Option 117	Adds Secure Memory Erase.
Option 122	Adds 80 MHz Bandwidth Digitizer. (E4440A, E4443A, E4445A)
Option 123	Adds Microwave/ Millimeter Wave Preselector Bypass
Option 124	Adds Y-Axis Video Output.
Option 140	Adds 40 MHz Bandwidth Digitizer. (E4440A, E4443A, E4445A)



**Table 10-1 Assemblies**

Description	Part Number	E4440A	E4443A	E4445A	E4446A	E4447A	E4448A
AT1 2 dB Attenuator	0955-0301				X	X	X
AT2 3 dB Attenuator (Option 123)	0955-0246				X	X	X
AT3 3 dB Attenuator (Option 110)	08490-60010				X	X	X
AT4 4 dB Attenuator (Option 110)	0955-0583	X	X	X			
A1 Flat Panel Display (serial prefixes US/MY/SG 4611 and above) See <a href="#">Figure 10-29</a>	2090-0897	X	X	X	X	X	X
A1 Flat Panel Display Retrofit Kit (serial prefixes below US/MY/SG 4611 - replaces early 2090-0396 display)	E4440-60445	X	X	X	X	X	X
A1A1 Display Converter Board	E4440-63265	X	X	X	X	X	X
A2 Front Panel Interface (Includes Inverter Boards + cable)	E4440-63266	X	X	X	X	X	X
A2A1 and A2A2 Inverter Boards	0950-3379	X	X	X	X	X	X
RPG (on the Front Panel Interface assembly)	1990-1865	X	X	X	X	X	X
A3 Keyboard Assembly (Key pad not included)	E4406-60004	X	X	X	X	X	X
A5 Power Supply Assembly	0950-4447	X	X	X	X	X	X
A6 SCSI Interface Board (with attached cover plate; serial prefixes US/MY/SG 4611 and above have A39 card installed in place of A6)	E4406-60065	X	X	X	X	X	X
A7 Digital IF retrofit kit for PSA when replacing Digital IF P/N E4440-60025, E4440-60195	E4440-60711	X	X	X	X	X	X

**Table 10-1 Assemblies**

Description	Part Number	E4440A	E4443A	E4445A	E4446A	E4447A	E4448A
A7 Digital IF Assembly (serial prefixes US/MY/SG 4611 and above. Also Option 122/140, 124)	E4440-60206	X	X	X	X	X	X
A8 Analog IF Assembly	E4440-60256	X	X	X	X	X	X
A9 2nd LO/ Fan Control	E4440-60431	X	X	X	X	X	X
A10 3rd Converter Assy <sup>a</sup>	E4440-60261	X	X	X	X		X
A10 3rd Converter Assy (includes W18 permanently attached)	E4447-60002					X	
A11 Reference Assembly	E4440-60225	X	X	X	X	X	X
A12 Synthesizer Assembly (includes A12A1 and A12A2 boards plus shields, and MMCX cables) <sup>b</sup>	E4440-60185	X	X	X	X	X	X
A12A1 LO/Synthesizer Bd <sup>b</sup>	E4440-60283	X	X	X	X	X	X
A12A2 Sampling Oscillator Board	E4440-60009	X	X	X	X	X	X
A12W1 Cable, MMCX coax, Sampler Signal (120 mm)	8121-0152	X	X	X	X	X	X
A12W2 Cable, MMCX coax, 600 MHz Ref (325 mm)	8121-0151	X	X	X	X	X	X
A13 Front End Driver Board (serial prefix US/MY/SG 4251 and above) <sup>b</sup>	E4440-60259	X	X	X			
	E4446-60166				X	X	X
A13 Front End Driver Bd Replacement Kit (serial prefix US/MY/SG 4222 and below) <sup>b</sup>	E4440-60434	X	X	X			
	E4446-60014				X	X	X
A14 Input Attenuator (4 dB)/Switch/Block cap)	33360-60003	X	X	X			

**Table 10-1 Assemblies**

<b>Description</b>	<b>Part Number</b>	<b>E4440A</b>	<b>E4443A</b>	<b>E4445A</b>	<b>E4446A</b>	<b>E4447A</b>	<b>E4448A</b>
A14 Input Attenuator (10 dB)/Switch)	33326-60009				X	X	X
A15 Input Attenuator (66 dB)	33321-60058	X	X	X			
A15 Input Attenuator (60 dB)	33325-60009				X	X	X
A18 YTO, 2.9 to 7 GHz (Yig Tuned Oscillator)	E4440-60023	X	X	X	X	X	X
A19 RYTHM, 26.5 GHz (Routing YIG Tuned Harmonic Mixer)	5087-7070	X					
A19 Refurbished RYTHM, 26.5 GHz	5087-6070	X					
A19 RYTHM, 6.7 and 13.2 GHz	5087-7183		X	X			
A19 Refurbished RYTHM, 6.7 and 13.2 GHz	5087-6183		X	X			
A19 SBTX/RYTHM Assembly, 44 GHz	5087-7184				X	X	
A19 Refurbished SBTX/RYTHM Assembly, 44 GHz	5087-6184				X	X	
A19 SBTX/RYTHM Assembly, 50 GHz	5087-7185						X
A19 Refurbished SBTX/RYTHM Assembly, 50 GHz	5087-6185						X
A19FL1 Filter cable, 27 GHz, SBTX to RYTHM	Not available separately				X	X	X
A20 Low Band Assembly	E4440-60217	X	X	X	X	X	X
A21 SLODA (Switched LO Distribution Amplifier)	5087-7700	X	X	X			
A21 FELOMA (Frequency Extended LO Multiplying Amplifier)	5087-7126				X	X	X

**Table 10-1 Assemblies**

Description	Part Number	E4440A	E4443A	E4445A	E4446A	E4447A	E4448A
A22 Preamp Assembly (Option 1DS) <sup>c</sup>	E4440-60444	X	X	X	X	X	X
A23 Floppy Disk Drive	0950-2782	X	X	X	X	X	X
A25 Motherboard	E4440-60001	X	X	X	X	X	X
A26 CPU (Processor) (includes standoffs; does not include A26A1 DRAM assy or A26A2 Flash Memory assy)	E4406-60060	X	X	X	X	X	X
A26A1 128M DRAM Assy (includes replacement standoffs)	E4406-60053	X	X	X	X	X	X
A26A2 64 MB Flash Memory Replacement Kit (includes replacement standoffs)	E4440-60094	X	X	X	X	X	X
A26BTI Battery, Lithium Polycarbon Monofluoride (3V, 0.16AH Panasonic BR2325)	1420-0314	X	X	X	X	X	X
A27 Electronic Attenuator (Option B7J)	E4440-60456	X	X	X	X	X	X
A28 Audio Out Board	E4406-60025	X	X	X	X	X	X
A29 SBTX Driver Board	E4446-60005				X	X	X
A30 FIFA, First IF Amplifier Assembly	E4446-60007				X	X	X
A31 Wideband Analog IF Assembly (Option 122 or 140)	E4440-60215	X	X	X	X		X
A32 Wideband Digital IF Assembly (Option 122 or 140)	E4440-60262	X	X	X	X		X
A33 70 MHz Output Assembly (Option H70)	E4440-60424	X	X	X	X		X
A34 Dual Mixer (Option 123)	5086-7749	X	X	X			

**Table 10-1 Assemblies**

<b>Description</b>	<b>Part Number</b>	<b>E4440A</b>	<b>E4443A</b>	<b>E4445A</b>	<b>E4446A</b>	<b>E4447A</b>	<b>E4448A</b>
A34 Unpreselected mm-Wave Mixer (Option 123)	1NB7-8539				X	X	X
A35 Mixer Bias Board (Option 123) (requires replacement of thermal pad, N1996-40018)	E4440-60254				X	X	X
A36 Microwave Preamp 26.5 GHz (Option 110)	0955-1663	X	X	X			
A36 Millimeter Preamp 50 GHz (Option 110)	0955-1617				X	X	X
A37 Audio Digitizer Assembly (Option 107)	E4440-60264	X	X	X	X	X	X
A38 Option Driver Assembly (Option 110/123)	E4440-60459	Opt 110	Opt 110	Opt 110	Opt 110 Opt 123	Opt 110 Opt 123	Opt 110 Opt 123
A39 USB/Memory Board (cover plate not attached; includes memory card) (Option 111, 115, 117)	E4440-60252	X	X	X	X	X	X
A39A1 512 MB Flash Card (Option 115)	1819-0163	X	X	X	X	X	X
B1, B2, or B3 Fan (fan, wires/connector + EMI disk)	E4406-60159	X	X	X	X	X	X
FL1 Low Pass Filter, 3 GHz	0955-0988	X	X	X	X	X	X
FL2 Band Pass Filter, 3.9214 GHz	0955-1074	X	X	X	X	X	X
FL2 Band Pass Filter, 3.900 GHz (Option 122 or 140)	0955-1391	X	X	X	X		X
FL3 Low Pass Filter, 4.4 GHz (Option 122 or 140)	0955-0519	X	X	X	X		X

**Table 10-1 Assemblies**

Description	Part Number	E4440A	E4443A	E4445A	E4446A	E4447A	E4448A
FL4 High Pass Filter, 3 GHz	0955-1906	Opt 110 and Opt 123	Opt 110 and Opt 123	Opt 110 and Opt 123			
SW1 RF Switch 1 Bottom Switch (Option 123)	33314-60013	X	X	X			
SW2 RF Switch 2 Top Switch (Option 123) (must also order shield, SW2. see Mechanical Parts table)	33314-60013	X	X	X			
SW3 Coaxial Switch (Option 123)	N1810-60052				X	X	X
SW4 Millimeter XFER Switch 50 GHz (top switch) (Option 110)	87222-60015				X	X	X
SW5 Switch, Millimeter (bottom switch) (Option 123)	87222-60015				X	X	X
SW6 Switch, Microwave (Option 110)	N1811-60005	X	X	X			
50 $\Omega$ termination for LO OUT port of A21 SLODA or Option AYZ 1st LO OUT	1810-0118	X	X	X			

- a. Instruments need a firmware update to  $\geq$  revision A.03.03 when replacing this assembly.
- b. Instruments need a firmware update to  $\geq$  revision A.04.08 when replacing this assembly.
- c. Instruments need a firmware update to  $\geq$  revision A.06.04 when replacing this assembly.

**Table 10-2 Mechanical Parts**

Description	Part Number	E4440A	E4443A	E4445A	E4446A	E4447A	E4448A
Dress Panel, rear	E4440-00059	X	X	X	X	X	X
Disk Drive Board	E4406-60014	X	X	X	X	X	X
Disk Drive Mount	E4406-40006	X	X	X	X	X	X
L-bracket, RF Main	E4440-00001	X	X	X			
	E4446-00003				X	X	X
RF Frame	E4440-20165	X	X	X	X	X	X
Bracket, Electronic Attenuator (Option B7J)	E4440-00024	X	X	X	X	X	X
Bracket, Bandpass Filter	E4440-00022	X	X	X	X	X	X
Bracket, RF Micro	E4440-00002	X	X	X			
	E4446-00001				X	X	X
Bracket, RF Attenuators	E4440-00017	X	X	X			
	E4446-00002				X	X	X
Lid, A18 YTO	E4440-00019	X	X	X	X	X	X
Shield, A18 YTO	E4440-00018	X	X	X	X	X	X
Screw, M3 x 0.58 MM long	0515-0372	X	X	X	X	X	X
Grommet, A18 YTO (2 each)	0400-0333	X	X	X	X	X	X
Shoulder Washers, A18 YTO (2 each)	5022-0179	X	X	X	X	X	X
Screw, A18 YTO Shield (2 each)	0515-0665	X	X	X	X	X	X
Cable clip for A15 Attenuator ribbon cable	1400-0611	X	X	X	X	X	X
Standoffs, Memory boards	0380-4163	X	X	X	X	X	X
Screwlock, GPIB .327 x 6-32	0380-0644	X	X	X	X	X	X
Washer, lock for GPIB Screwlock, 0.194 ID	2190-0577	X	X	X	X	X	X

**Table 10-2 Mechanical Parts**

<b>Description</b>	<b>Part Number</b>	<b>E4440A</b>	<b>E4443A</b>	<b>E4445A</b>	<b>E4446A</b>	<b>E4447A</b>	<b>E4448A</b>
Bracket, Switch (Option 123)	E4440-00020	X	X	X			
Shield, SW2 (Top Switch) (Option 123)	E4440-00055	X	X	X			
Washer, lock for BNC connector mounting	2190-0068	X	X	X	X	X	X
Screwlock, 0.312 x 4-40	0380-1858	X	X	X	X	X	X
Screwlock, SCSI	1252-5828	X	X	X	X	X	X
Nut, 15/32 - 32 Rear panel BNC connector mounting	0590-2332	X	X	X	X	X	X
Nut, 7/16 - 32 Rear panel SMA connector mounting	2950-0132	X	X	X	X	X	X
Washer for SMA	2190-0104	X	X	X	X	X	X
Star washer for BNC connectors	2190-0102	X	X	X	X	X	X
Nylon spacer .25 round (4 spacers keep the CPU from bending when vertical boards are inserted)	0380-4662	X	X	X	X	X	X
CPU shim	E4406-00079	X	X	X	X	X	X
CPU shim	E4406-00076	X	X	X	X	X	X
Shield, magnetic (used inside instrument cover, 2 places)	E4440-00029	X	X	X	X	X	X
Instrument Cover (enclosure)	E4440-00004	X	X	X	X	X	X
Top Brace	E4440-00013	X	X	X	X	X	X
Rear "foot"	5041-9611	X	X	X	X	X	X
Bottom "foot"	5041-9167	X	X	X	X	X	X
Key lock for bottom instrument feet	5021-2840	X	X	X	X	X	X



**Table 10-2 Mechanical Parts**

Description	Part Number	E4440A	E4443A	E4445A	E4446A	E4447A	E4448A
Spring-Wire Frame (for two front bottom feet)	1460-1345	X	X	X	X	X	X
Front Frame Assy. (includes EMI gaskets and “trim strips”)	E4406-60155	X	X	X	X	X	X
Rear Frame Assy. (includes EMI gaskets)	E4406-60154	X	X	X	X	X	X
Front Dress Panel (includes keyboard overlay label)	E4440-60080	X	X	X	X	X	X
Deck Assy. (chassis)	E4440-00028	X	X	X	X	X	X
Strap Handle Assembly	E4440-60066	X	X	X	X	X	X
Front Shield	E4440-00050	X	X	X	X	X	X
Keypad	E4440-40003	X	X	X	X	X	X
RPG Knob	0370-3229	X	X	X	X	X	X
Nut for RPG, M6x0.5	0535-0163	X	X	X	X	X	X
Volume Knob	0370-3230	X	X	X	X	X	X
Plug, Hole 0.5D, Nylon (for BNC hole)	6960-0149	X	X	X	X	X	X
Plug, Hole 0.25D, Nylon (for SMA hole)	6960-0076	X	X	X	X	X	X
Line Key (push rod) Compression Spring Retainer Ring	E4406-40005 1460-2580 0510-1055C	X	X	X	X	X	X
Dress Panel, SCSI	E4406-00017	X	X	X	X	X	X
Display EMI Filter	1000-1001	X	X	X	X	X	X
Display Mount (serial prefix below US/MY/SG 4611 order Flat Panel Display Retrofit Kit. See <a href="#">Table 10-1.</a> )	(If the kit is previously installed, the display and display mount will look like <a href="#">Figure 10-29</a> )	X	X	X	X	X	X
Display Mount (serial prefix US/MY/SG 4611 and above)	E4406-40013	X	X	X	X	X	X

**Table 10-2 Mechanical Parts**

<b>Description</b>	<b>Part Number</b>	<b>E4440A</b>	<b>E4443A</b>	<b>E4445A</b>	<b>E4446A</b>	<b>E4447A</b>	<b>E4448A</b>
Display Pressure Plate	E4406-00037	X	X	X	X	X	X
Display Bezel Assembly (includes left overlay label, but does not include nameplate)	E4440-60081	X	X	X	X	X	X
Mid Web	E4406-20109	X	X	X	X	X	X
Spacer for switches (Option 123)	0380-1402	X	X	X			
Screw, M3 x 0.05 5.4 LG for switch mounting (Option 123)	0515-1715	X	X	X			
Thermal Pad (Option 123)	N1996-40018				X	X	X
Rivet, fan mounting	0361-1272	X	X	X	X	X	X
Fan Guard	3160-0281	X	X	X	X	X	X
Rivet, fan guard mounting	0361-1888	X	X	X	X	X	X
Cable hold down (on Midweb)	5022-6135	X	X	X	X	X	X
Cable Clamp, plastic, adhesive backed (Option 110, 123)	1400-0611	X	X	X	X	X	X
Cable Clip Sleeves (numbers 0-9, 1 wand for each number, each wand has > 10 numbers)	7121-8265	X	X	X	X	X	X
Bracket, FIFA/cable restraint for Lowband assembly	E4447-60001					X	
Screw, M2.5 X 0.45, 6 MM, TORX (Option 110, 123) Attaches SW4 and SW5 to bracket	0515-1934				X	X	X
Screw, 2-56 .312 in, POZI Attaches A36 P-Amp to bracket	0520-0129				X	X	X

**Table 10-2 Mechanical Parts**

Description	Part Number	E4440A	E4443A	E4445A	E4446A	E4447A	E4448A
Screw, M3 x 0.5 20 MM (Option 110)	0515-1410	X	X	X			
Screw M3 X 0.5 16 MM (Option 123) Attaches SW3 to to bracket	0515-0375				X	X	X
Screw M3.5 X 0.6 8 MM TORX (Option 110, 123) Attaches mixer bracket to chassis	0515-0458				X	X	X
Nut, hex, 15/32-32 For Ext IN and Audio In BNC cables (Option 107)	2950-0035	X	X	X	X	X	X
Washer, Lock HLCL NO. 2 0.088 in ID Used for A36 amplifier mounting	2190-0112				X	X	X
Bracket, Switch/Preamp (Option 110)	E4440-00051	X	X	X			
Bracket, Unpreselected Mixer (Option 110, 123)	E4440-00062				X	X	X
Bracket, Preamp (Option 110)	E4440-00075				X	X	X
Bracket, Coax Switch (Option 123)	E4440-00076				X	X	X
Bracket, Switch (Option 110, 123)	E4440-00063				X	X	X
Shield, Inverter Board	E4440-00068	X	X	X	X	X	X
Cover plate, rear panel, USB/Flash Board (Option 111, 115)	E4440-00061	X	X	X	X	X	X
Screw, M3 X 0.5 6 mm long	0515-0430				X	X	X
Hook and Loop fastener (Velcro) for FL2	0510-1303				X	X	X

**Table 10-3 Cables<sup>a</sup>**

Description	Part Number	E4440A	E4443A	E4445A	E4446A	E4447A	E4448A
W1 Cable (5), coax, Front Panel External Trigger to A8 Analog IF Assy. P1	E4406-60139	X	X	X	X	X	X
W2 Cable, ribbon 100 pin, Front Panel	E4440-60075	X	X	X	X	X	X
W5 Cable Flat flex, Front Panel Interface to flat panel display (for serial prefix below US/MY/SG 4611)	8120-8480	X	X	X	X	X	X
W5 Cable Flat flex, Front Panel Interface to display converter board (for serial prefix US/MY/SG 4611 and above)	8121-1419	X	X	X	X	X	X
W6 Cable flat flex, Disk drive to Motherboard	8120-8461	X	X	X	X	X	X
W7 Cable, semi-rigid (with ferrites), For standard "N" type RF Input to A14 Attenuator	E4440-20067	X	X	X			
W7 Cable, semi-rigid, For Option BAB 3.5 APC RF Input to A14 Attenuator	E4440-20099	X					
W7 Cable, semi-rigid, For standard 2.4mm RF Input to A14 Attenuator	E4446-20020				X	X	X
W8 Cable, semi-rigid (with ferrites), A14 attenuator to A15 attenuator	E4440-20068	X	X	X			
	E4446-20021				X	X	X
W9 Cable, semi-rigid, A15 Attenuator to A19 RYTHM	E4440-20069	X	X	X			
W10 Cable (8), coax, 7.5 MHz from A8 Analog IF P2, to A7 Digital IF, P1	8120-5022	X	X	X	X	X	X

**Table 10-3 Cables<sup>a</sup>**

Description	Part Number	E4440A	E4443A	E4445A	E4446A	E4447A	E4448A
W11 Cable (3), coax, 21.4 MHz from A10 3rd Converter J5 to A8 Analog IF, J13	8120-5021	X	X	X	X	X	X
W12 Cable (6), coax, TRIGGER IN from rear panel to A8 Analog IF, P4	8120-5053	X	X	X	X	X	X
W13 Cable (20), coax, TRIGGER 1 OUT to A9 2nd LO, J12	8121-0153	X	X	X	X	X	X
W14 Cable (30), coax, TRIGGER 2 OUT to A9 2nd LO, J11	8121-0153	X	X	X	X	X	X
W15 Cable, semi-rigid, A9 2nd LO, J10 to Lowband, J5	E4440-20084	X	X	X	X	X	X
W16 Cable (4), coax, 600 MHz from A11 Reference board P3 to A9 2nd LO, J1	8120-5022	X	X	X	X	X	X
W17 Cable (10), coax (with ferrites), A19 RYTHM highband output to A10 3rd Converter J1	E4440-60371	X	X	X	X	X	X
W18 Cable (7), coax (with ferrites), 321.4 MHz A20 Lowband assy to A10 3rd Converter J2	E4440-60372	X	X	X	X	X	X
W19 Cable (40), coax 321.4 MHz IF OUT from A10 3rd Converter J4 to rear panel	8121-0149	X	X	X	X		X
W20 Cable (50), coax, 50 MHz Cal signal from A10 3rd Converter J7 to A14 Attenuator	8121-0156	X	X	X	X	X	X
W21 Cable (90), coax, 10 MHz Out from A11 Reference Assy P2 to rear panel	8120-5053	X	X	X	X	X	X

**Table 10-3 Cables<sup>a</sup>**

Description	Part Number	E4440A	E4443A	E4445A	E4446A	E4447A	E4448A
W22 Cable (70), coax, Ext Ref In from rear panel to A11 Reference Assy P1	8120-5053	X	X	X	X	X	X
W23 Cable, coax, 28V to rear panel from A13 Front End Driver	8121-0958	X	X	X	X	X	X
W24 Cable, semi-rigid, A21 SLODA to A12 Synthesizer	E4440-20082	X	X	X			
W24 Cable, semi-rigid, A21 FELOMA to A12 Synthesizer	E4446-20036				X	X	X
W25 Cable, ribbon, YTO Control	E4440-60069	X	X	X	X	X	X
W26 Cable, ribbon, RYTHM Control	E4440-60070	X	X	X	X	X	X
W27 Cable, backlight extension (for serial prefix US/MY/SG 4644 and above)	8121-1420	X	X	X	X	X	X
W28 Wire harness, SLODA control, from A13 Front End Driver to A21 SLODA	E4440-60067	X	X	X			
W29 Cable, ribbon, A13 Front End Driver to A14 Attenuator A	E4440-60071	X	X	X	X	X	X
W30 Cable, ribbon, A13 Front End Driver to A15 Attenuator B	E4440-60071	X	X	X	X	X	X
W31 Cable, ribbon, A13 Front End Driver to A20 Lowband Assy.	E4440-60072	X	X	X	X	X	X
W32 not assigned							
W33 Cable, semi-rigid, A15 Attenuator to W34	E4446-20022				X	X	X
W34 Cable, semi-rigid, W33 to A19 SBTX/RYTHM	E4446-20023				X	X	X

**Table 10-3 Cables<sup>a</sup>**

Description	Part Number	E4440A	E4443A	E4445A	E4446A	E4447A	E4448A
W35 Cable, semi-rigid, YTO Output A18 YTO to A21 SLODA	E4440-20083	X	X	X			
W35 Cable, semi-rigid, YTO Output A18 YTO to A21 FELOMA	E4446-20033				X	X	X
W36 Cable, semi-rigid, A19 RYTHM to FL1 Low Pass Filter (except Option B7J)	E4440-20071	X	X	X			
W36 Cable, semi-rigid, A19 SBTX/RYTHM to FL1 Low Pass Filter (except Option B7J)	E4446-20031				X	X	X
W37 Cable, semi-rigid, FL1 Low Pass Filter to A20 Lowband Assy. J1 (except Option 1DS)	E4440-20074	X	X	X			
	E4446-20037				X	X	X
W38 Cable, semi-rigid, LO signal A21 SLODA to A19 RYTHM	E4440-20070	X	X	X			
W38 Cable, semi-rigid, LO signal A21 FELOMA to A19 SBTX/RYTHM	E4446-20030				X	X	X
W39 Cable, semi-rigid, Bandpass Filter Output, 3.9 MHz Bandpass Filter to A20 Lowband J4	E4440-20081	X	X	X			
	E4446-20058				X	X	X
W40 Cable, semi-rigid, Bandpass Filter Input, A20 Lowband J3 to FL2, 3.9 MHz Bandpass	E4440-20080	X	X	X			
W41 Cable, semi-rigid, A21 SLODA to A20 Lowband Assy.	E4440-20076	X	X	X			
W41 Cable, semi-rigid, A21 FELOMA to A20 Lowband Assy.	E4446-20034				X	X	X
W42 Cable, semi-rigid, A19 SBTX/RYTHM LO1 to AT1	E4446-20027				X	X	X

**Table 10-3 Cables<sup>a</sup>**

Description	Part Number	E4440A	E4443A	E4445A	E4446A	E4447A	E4448A
W43 Cable, semi-rigid, AT1 to FELOMA J2 (SBTX)	E4446-20049				X	X	X
W44 Cable (9), coax, IF IN from front-panel to A10 3rd Converter J3 (Option AYZ)	E4440-60374	X			X	X	X
W45 Cable, semi-rigid, LO OUT from front-panel to W46 (Option AYZ)	E4440-20095	X			X	X	X
W46 Cable, semi-rigid, LO OUT extension cable from A21 SLODA 1st LO OUT to W45. (Option AYZ, for PSA ≤ 26.5 GHz)	E4440-20087	X					
W46 Cable, semi-rigid, LO OUT extension cable from A21 FELOMA LO OUT to W45. (Option AYZ and 123, for PSA > 26.5 GHz)	E4446-20035				X	X	X
W47 Cable (97), coax, Preselector Tune Out A13 Front End Driver to Rear Panel	8121-0153	X	X	X	X	X	X
W48 Cable, semi-rigid, FL1 Low Pass Filter to A22 Preamp Assy. (Option 1DS)	E4440-20072	X	X	X			
	E4446-20038				X	X	X
W49 Cable, ribbon, Preamp control from A13 Front End Driver to A22 Preamp Assy. (Option 1DS)	E4440-60073	X	X	X	X	X	X
W50 Cable, semi-rigid, Preamp Out from A22 Preamp to Lowband (Option 1DS)	E4440-20079	X	X	X	X	X	X
W51 Cable, semi-rigid, A19 SBTX/RYTHM out to A27 Electronic Attenuator (Option B7J)	E4440-20110	X	X	X			
	E4446-20039				X	X	X



**Table 10-3 Cables<sup>a</sup>**

<b>Description</b>	<b>Part Number</b>	<b>E4440A</b>	<b>E4443A</b>	<b>E4445A</b>	<b>E4446A</b>	<b>E4447A</b>	<b>E4448A</b>
W52 Cable, semi-rigid, A27 electronic attenuator to FL1, 3 GHz Low Pass Filter (Option B7J)	E4440-20109	X	X	X			
	E4446-20040				X	X	X
W53 Cable ribbon, Electronic Attenuator control from A13 Front End Driver to A27 Electronic Attenuator (Option B7J)	E4440-60078	X	X	X	X	X	X
W54 Cable, semi-rigid, A20 Lowband J3 to FIFA middle connector	E4446-20044				X	X	X
W55 Cable, semi-rigid, A19 SBTX to FIFA rear connector	E4446-20045				X	X	X
W56 Cable, semi-rigid, FIFA to FL2 Band Pass filter	E4446-20046				X	X	X
W57 not assigned							
W58 Cable, ribbon, A13 Front End Driver J10 to A30 FIFA	E4440-60073				X	X	X
W59 not assigned							
W60 Cable, ribbon, ADC Data from A31 WB Analog IF to A32 WB Digital IF (Option 122 or 140)	E4440-60341	X	X	X	X		X
W61 Cable (65), coax, 100 MHz Ref from A11 Reference Assembly to A31 WB Analog IF (Option 122 or 140)	8121-1007	X	X	X	X		X
W62 Cable (95), coax, 300 MHz Ref from A11 Reference Assembly P4 to A31 WB Analog IF (Option 122 or 140)	8120-8863	X	X	X	X		X
W63, not assigned							

**Table 10-3 Cables<sup>a</sup>**

Description	Part Number	E4440A	E4443A	E4445A	E4446A	E4447A	E4448A
W64 Cable (60), coax, WB IF CA:L from A31 WB Analog IF to A10 3rd Converter J6 (Option 122 or 140)	8121-1007	X	X	X	X		X
W65 Cable (40), coax, 321.4 MHz IF from A10 3rd Converter J4 to A31 WB Analog IF (Option 122 or 140)	E4440-60343	X	X	X	X		X
W66 Cable (66), coax, 321.4 MHz from A31 WB Analog IF to Rear Panel (Option 122 or 140)	8121-1323	X	X	X	X		X
W67 Cable, coax, Video Out from Digital IF J100 to Rear Panel (Option 124)	8121-0964	X	X	X	X	X	X
W68 Cable, ribbon, SBTX Tower Control, A29 SBTX Driver to A19 SBTX/RYTHM	E4446-60008				X	X	X
W69 Cable, ribbon, 20 pin, SBTX Digital Control, A29 SBTX Driver to A13 Front End Driver	E4446-60009				X	X	X
W70 Cable, ribbon, 14 pin, SBTX Power, A29 SBTX Driver to A13 Front End Driver	E4446-60010				X	X	X
W71 Cable, ribbon, FELOMA, A29 SBTX Driver to A21 FELOMA	E4446-60011				X	X	X
W75 Cable (41), coax, 70 MHz IF OUT, from A33 Option card J2 to rear panel (Option H70)	8121-0705	X	X	X	X	X	X
W76 Cable (40), coax, 321.4 MHz IF IN, from A10 3 <sup>rd</sup> Converter J4 to A33 Option card J1 (Option H70)	8121-0704	X	X	X	X	X	X

**Table 10-3 Cables<sup>a</sup>**

<b>Description</b>	<b>Part Number</b>	<b>E4440A</b>	<b>E4443A</b>	<b>E4445A</b>	<b>E4446A</b>	<b>E4447A</b>	<b>E4448A</b>
W77 Cable (51), coax, 321.4 MHz IF OUT, from A33 Option card J5 to rear panel (Option H70)	8121-0705	X	X	X	X	X	X
W78 Cable, semi-rigid, FL2 to FL3 (Option 122 or 140)	E4446-20047	X	X	X	X		X
W79 Cable, semi-rigid, FL3 to A20 Lowband (Option 122 or 140)	E4446-20048	X	X	X	X		X
W80 Cable, semi-rigid, Input Attenuator to Switch 1 (Option 123)	E4440-20090	X	X	X			
W81 Cable, semi-rigid (with ferrites), Switch 1 (bottom switch) port 2 to RYTHM input (Option 123)	E4440-20091	X	X	X			
W82 Cable, semi-rigid, Switch 1 (bottom switch) port 1 to Mixer input (Option 123)	E4440-20092	X	X	X			
W83 Cable, semi-rigid, Mixer LO IN to cable W88 from SLODA LO Out (Option 123)	E4440-20093	X	X	X			
W84 Cable (1), coax, Dual Mixer Out to Switch 2 (top switch) port 1 (Option 123)	E4440-60298	X	X	X			
W85 Wire Harness, FE Driver J11 to Switches/Mixer (Option 123)	E4440-60077	X	X	X			
W86 Cable (10), coax, 3rd Converter J1 to Switch 2 (top switch) port C (Option 123)	E4440-60373	X	X	X			

**Table 10-3 Cables<sup>a</sup>**

Description	Part Number	E4440A	E4443A	E4445A	E4446A	E4447A	E4448A
W87 Cable (2), coax, RYTHM to Switch 2 (top switch) port 2 (Option 123)	E4440-60373	X	X	X			
W88 Cable, semi-rigid, SLODA LO Out to cable W83 Mixer LO In (Option 123)	E4440-20087	X	X	X			
W89, Cable, coax, Switch 3 bottom port to RHYTHM/SBTX (Option 123)	E4440-60373				X	X	X
W90 Cable, Flat Flex, Unpreselected mixer to mixer bias board (Option 123)	8150-5698				X	X	X
W91, Cable, ribbon, Switch Control, Option Driver Assy J3 to SW4 (top switch) (Option 110)	E4440-60455				X	X	X
W92, Cable, ribbon, Switch Control Option Driver Assy J8 to SW5 (bottom switch) (Option 123)	E4440-60455				X	X	X
W93, Cable, coax, Unpreselected mixer to Switch 3 coax switch top port (Option 123)	E4440-60298				X	X	X
W94, Cable, coax, SW3 coax switch center connector to 3rd Converter (Option 123)	E4440-60373				X	X	X
W95, Cable, ribbon, Mixer Bias board control. Option Driver Assy J7 to Mixer Bias Board (Option 123)	E4440-60397				X	X	X
W96, Cable, ribbon, Driver board J9 to coax switch (Option 123)	E4440-60427				X	X	X

**Table 10-3 Cables<sup>a</sup>**

<b>Description</b>	<b>Part Number</b>	<b>E4440A</b>	<b>E4443A</b>	<b>E4445A</b>	<b>E4446A</b>	<b>E4447A</b>	<b>E4448A</b>
W97, not assigned							
W98, Cable, semi-rigid, LO In to Unpreselected Mixer from W46/3 dB pad (Option 123)	E4446-20074				X	X	X
W99, Cable, semi-rigid, Unpreselected mixer to switch 5 (bottom switch) Port 4 (Option 123)	E4446-20318				X	X	X
W100, Cable, semi-rigid, Switch 5 port 1 from attenuator (Option 123, for instruments that do not have Option 110)	E4446-20071				X	X	X
W101, Cable, semi-rigid, Switch 4 port 4 to Switch 5 port 1 (Option 123, for combination of Option 110 with Option 123)	E4446-20081				X	X	X
W102, Cable, semi-rigid, A15 Attenuator out to Switch 4 port 1 (Option 110)	E4446-20077				X	X	X
W103, Cable, semi-rigid, Preamp In from Switch 4 port 2 (Option 110)	E4446-20078				X	X	X
W104, Cable, semi-rigid, Preamp out to Switch 4 port 3 (Option 110)	E4446-20083				X	X	X
W105, Cable, semi-rigid, Switch 5 port 2 to W34 cable to A10 RHYTHM/SBTX (Option 123)	E4446-20080				X	X	X
W106, Wire Harness, Option Driver P1 to Preamp (Option 110)	E4446-60076	X	X	X	X	X	X

**Table 10-3 Cables<sup>a</sup>**

Description	Part Number	E4440A	E4443A	E4445A	E4446A	E4447A	E4448A
W107, Cable, semi-rigid, Switch 4 port 4 to W34 cable to RHYTHM/SBTX (Option 110, for instruments that do not have Opt 123)	E4446-20072				X	X	X
W108, Cable, coax, Front Panel Audio In to Audio Board Assy (Option 107)	8121-1432	X	X	X	X	X	X
W109, Cable semi-rigid A15 Attenuator to Switch 6 (Option 110 or Option 110 with Option 123)	E4440-20315	X	X	X			
W110, Cable, semi-rigid, Switch 6 to RHYTHM (when Option 110 is installed and Option 123 is not)	E4440-20316	X	X	X			
W111, Cable, semi-rigid, Switch 6 to Option 123 Switch 1 Center Port (Opt 110 with Option 123)	E4440-20317	X	X	X			
W112, Cable, semi-rigid, Preamp Out from Switch 6 (Option 110)	E4440-20323	X	X	X			
W113, Cable, semi-rigid, Preamp In from Switch 6 (Option 110)	E4440-20304	X	X	X			
W114, Cable, ribbon, Switch Control, Option Driver Assy to SW 6 for Option 110	E4440-60427	X	X	X			
W115, Cable, semi-rigid, FL4 to A34 (Option 110 + 123 combination)	E4440-20324	X	X	X			

a. The numbered clip sleeves are not included with the cables. Order mechanical part [7121-8265](#) to replace the clips.

**Table 10-4 Front Panel Connectors and Mounting Hardware**

Description	Part Number	E4440A	E4443A	E4445A	E4446A	E4447A	E4448A
J1 Input Connector, Type N	08559-60002	X	X	X			
Bracket, Type N Input	E4440-20185	X	X	X			
Input Connector Nut, Type N Input	2950-0132	X	X	X			
Input Connector Washer, Type N Input	2190-0104	X	X	X			
J1 Input Connector, 3.5 mm (m) (Option BAB)	08673-60040	X					
Bracket, 3.5 mm Input (Option BAB)	E4440-20094	X					
Input Connector Nut, 3.5 mm (Option BAB)	2950-0001	X					
Input Connector Washer, 3.5 mm (Option BAB)	2190-0016	X					
J1 Input Connector, 2.4 mm	5064-3970				X	X	X
Bracket, 2.4 mm RF Input	E4446-20004				X	X	X
Input Connector Nut, 2.4 mm	0590-2563				X	X	X
Ext Trigger – Front Panel (part of W1)	E4406-60139	X	X	X	X	X	X
Probe Power Part of A2 Front Panel Interface Assy	1252-7437	X	X	X	X	X	X
IF INPUT connector SMA (Option AYZ)	1250-1666	X			X	X	X
1 <sup>st</sup> LO OUT connector SMA (Option AYZ)	1250-1666	X			X	X	X
Nut, 1/4 - 36, LO OUT or IF INPUT (Option AYZ)	2950-0223	X			X	X	X
Nut, hex 15/32-32 for External Trigger IN and Audio IN	2950-0035	X	X	X	X	X	X

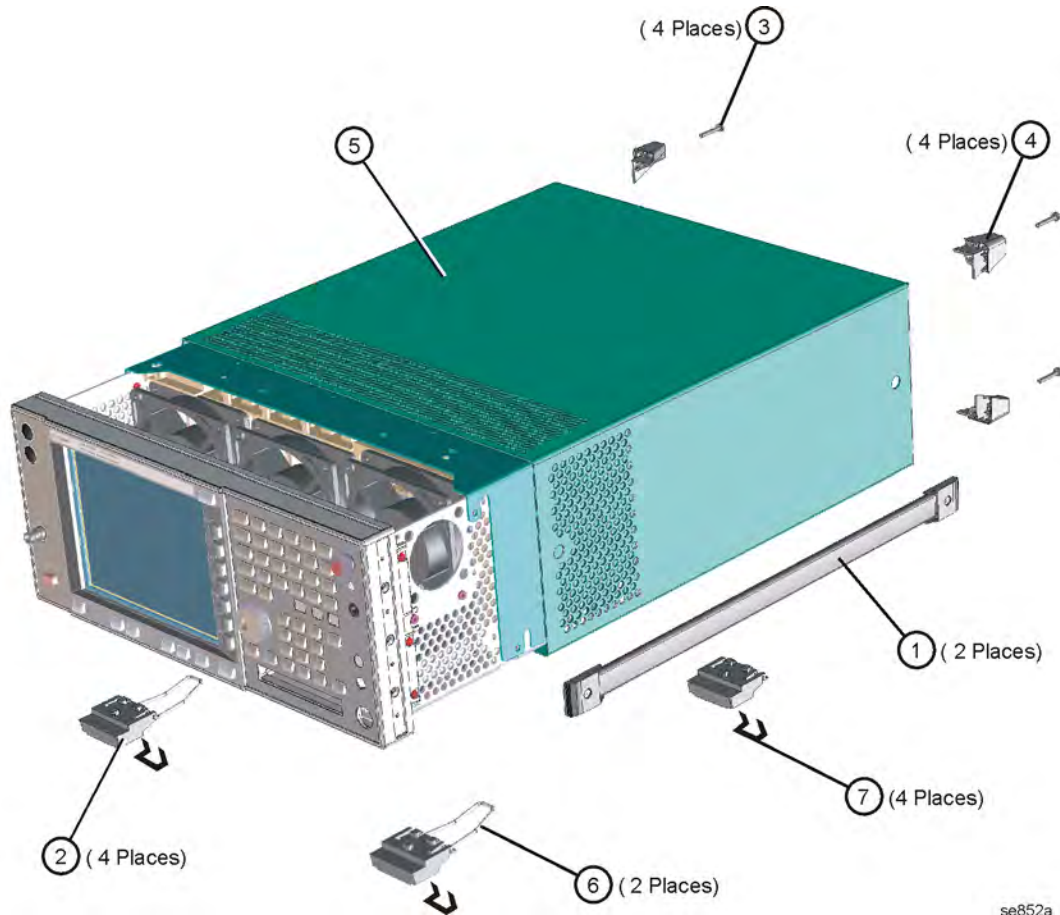
**Table 10-5      Labels**

<b>Description</b>	<b>Part Number</b>	<b>E4440A</b>	<b>E4443A</b>	<b>E4445A</b>	<b>E4446A</b>	<b>E4447A</b>	<b>E4448A</b>
Name Plate, E4440A	E4440-80003	X					
Name Plate, E4443A	E4443-80001		X				
Name Plate, E4445A	E4445-80001			X			
Name Plate, E4446A	E4446-80001				X		
Name Plate, E4447A	E4447-80001					X	
Name Plate, E4448A	E4448-80001						X
Line Label	E4440-80006	X	X	X	X	X	X
Trim, side strips	5041-9172	X	X	X	X	X	X
Label, USB port cover (Option 115)	E4440-80099	X	X	X	X	X	X
Label overlay, left front panel	E4440-80100	X	X	X	X	X	X
Warning label for cable	E4447-80002					X	



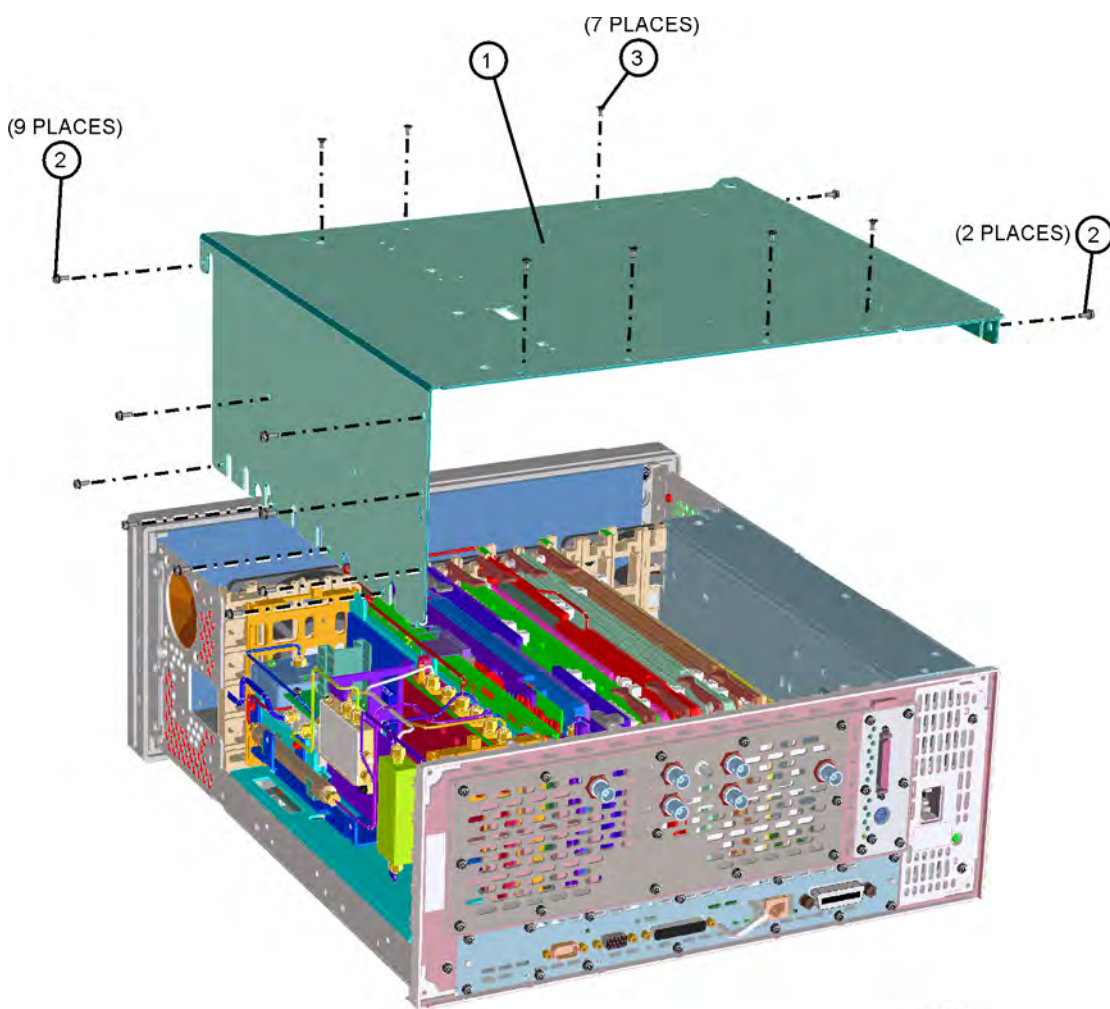
## Hardware

**Figure 10-1 External Hardware**



Item	Description	Agilent Part Number
1	Strap Handle Assembly	E4440-60066
2	Bottom "foot"	5041-9167
3	Screw M4x0.7 25mm-LG	0515-1619
4	Rear "foot"	5041-9611
5	Shield, magnetic (used inside instrument cover, 2 places)	E4440-00029
6	Spring-Wire Frame (for two front bottom feet)	1460-1345
7	Key lock for bottom instrument feet	5021-2840

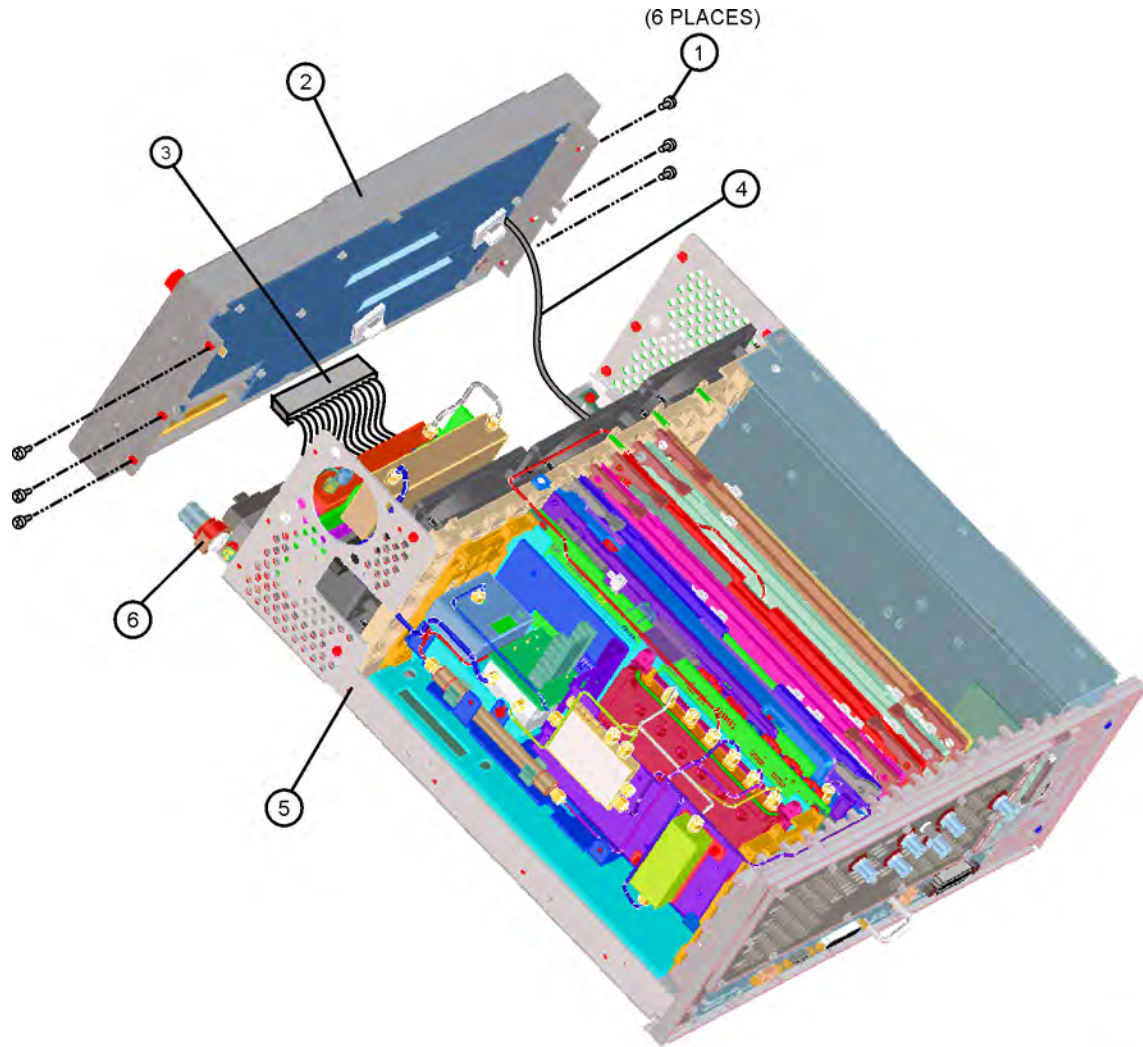
**Figure 10-2 Top Brace Hardware**



se85a

Item	Description	Agilent Part Number
1	Top Brace	E4440-00013
2	Screw M3x0.5 8mm-LG (Crest Washer-Pan Head-TORX)	0515-0372
3	Screw M3x0.5 6mm-LG (Flat Head)	0515-1227

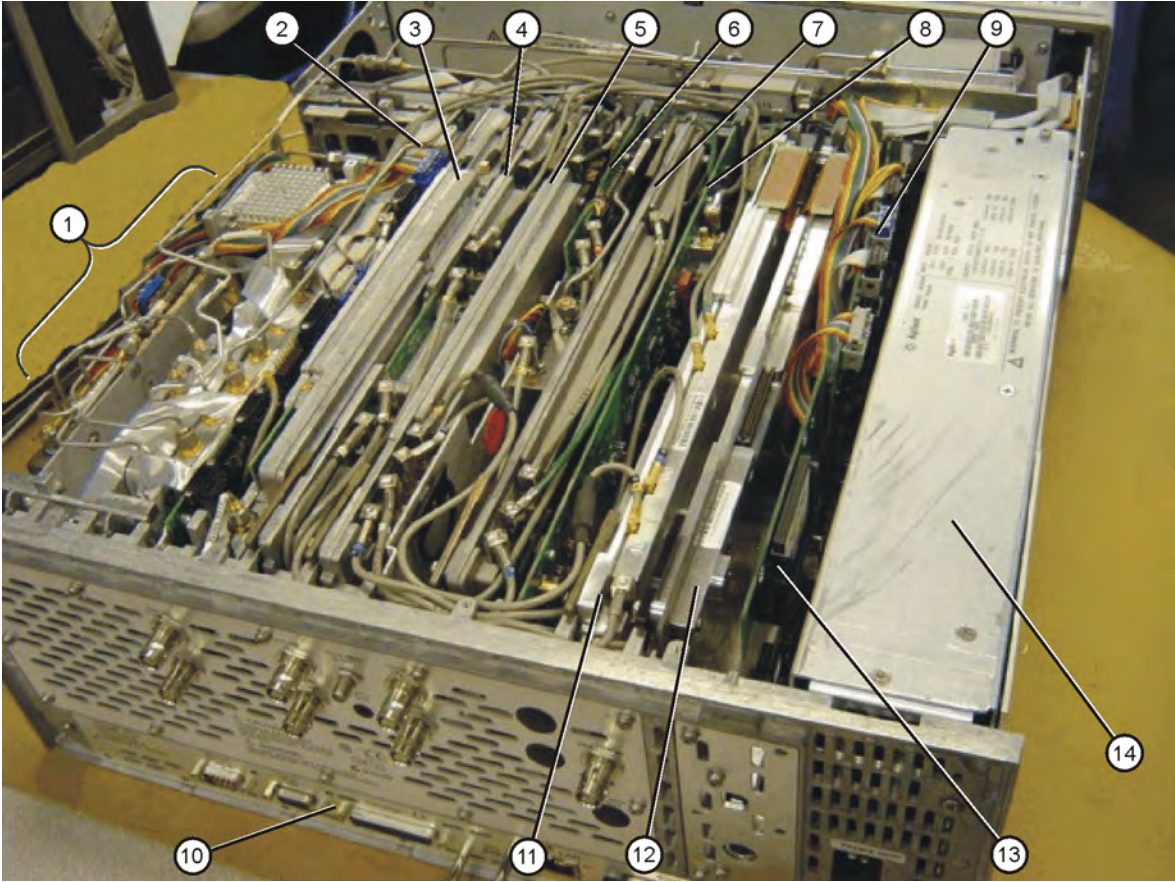
**Figure 10-3 Front Frame Hardware**



se86a

Item	Description	Agilent Part Number
1	Screw M3x0.5 8mm-LG (Crest Washer-Pan Head-TORX)	0515-0372
2	Front Frame Assembly	see <a href="#">page 292</a>
3	W2 Cable, ribbon 100 pin, Front Panel	E4440-60075
4	W1 Cable (5), coax, Front Panel External Trigger to A8 Analog IF Assy. P1	E4406-60139
5	Deck Assy. (chassis)	E4440-00028
6	Bracket, Type N Input Bracket, 3.5 mm Input (Option BAB)	E4440-20185 E4440-20094

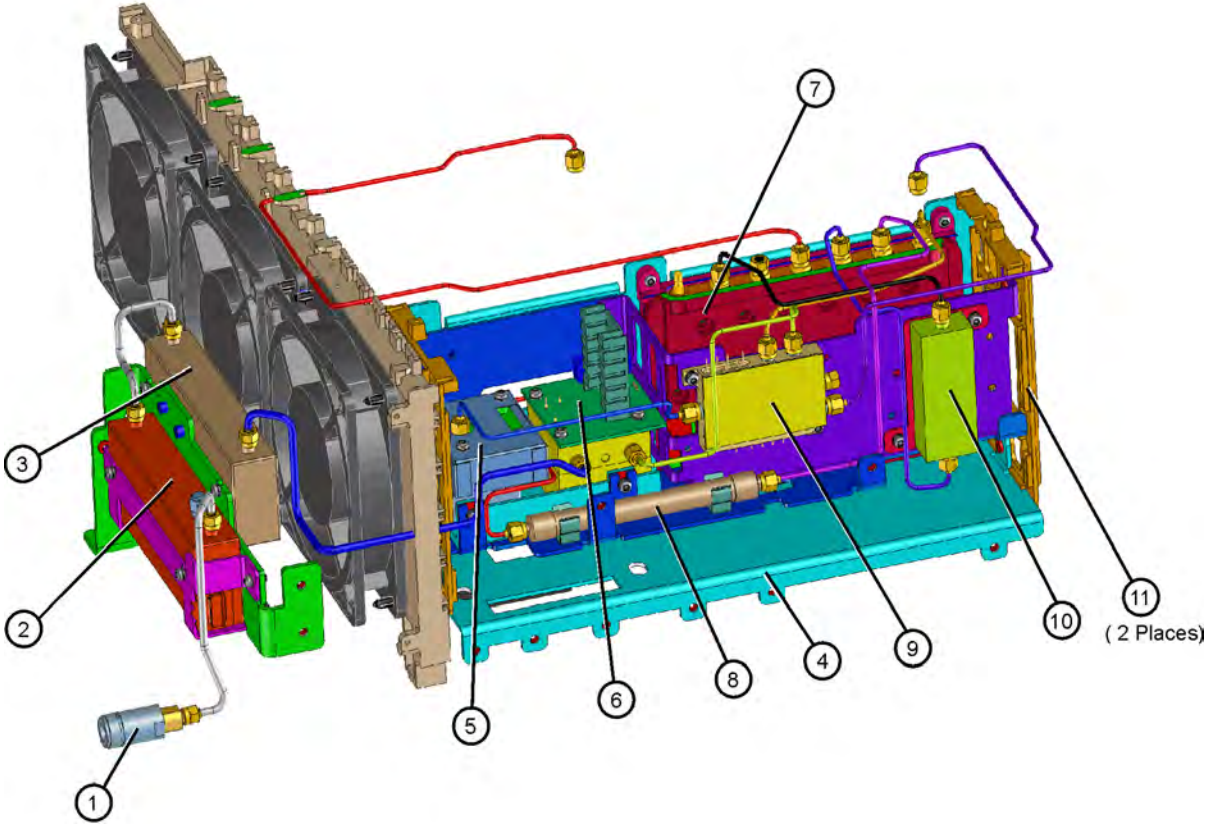
**Figure 10-4 Major Assemblies**



<b>Item</b>	<b>Description</b>	<b>Agilent Part Number</b>
1	RF Section	See page 254
2	A13 Front End Driver Board <sup>a</sup>	E4440-60259
3	A12 Synthesizer Assembly <sup>a</sup>	E4440-60185
4	A11 Reference Assembly	E4440-60225
5	A10 3rd Converter Assembly <sup>b</sup>	E4440-60261
6	A9 2nd LO/ Fan Control	E4440-60431
7	A8 Analog IF Assembly	E4440-60256
8	A7 Digital IF Assembly (serial prefixes US/MY/SG 4611 and above. Also Option 122/140, 124)	E4440-60206
9	A38 Option Driver Assembly (Option 110/123)	E4440-60459
10	A26 CPU Assembly	E4406-60060
11	A31 Wideband Analog IF Assembly (Option 122 or 140)	E4440-60215
12	A32 Wideband Digital IF Assembly (Option 122 or 140)	E4440-60262
13	A39 USB/Memory Board (cover plate not attached; includes memory card) (Option 111, 115, 117)	E4440-60252
14	A5 Power Supply Assembly	0950-4447

- a. Instruments need a firmware update to  $\geq$  revision A.04.08 when replacing this assembly.
- b. Instruments need a firmware update to  $\geq$  revision A.03.03 when replacing this assembly.

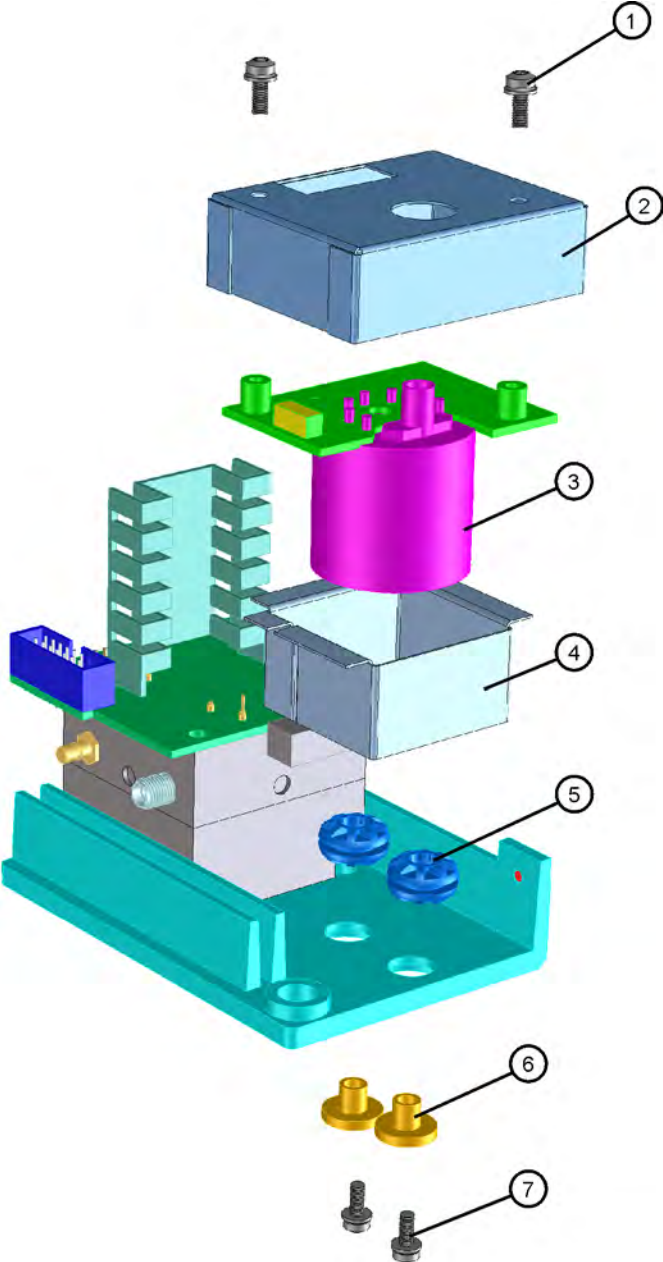
**Figure 10-5** RF Section  
**E4440A, E4443A, E4445A - Standard**



se819a

<b>Item</b>	<b>Description</b>	<b>Agilent Part Number</b>
1	J1 Input Connector, Type N	08559-60002
2	A14 Input Attenuator (4 dB)/Switch/Block cap)	33360-60003
3	A15 Input Attenuator (66 dB)	33321-60058
4	L-bracket, RF Main	E4440-00001
5	A18 YTO, 2.9 to 7 GHz (Yig Tuned Oscillator)	E4440-60023
6	A19 RYTHM, 26.5 GHz (Routing YIG Tuned Harmonic Mixer)	5087-7070
6	A19 RYTHM, 6.7 and 13.2 GHz	5087-7183
7	A20 Low Band Assembly	E4440-60217
8	FL1 Low Pass Filter, 3 GHz	0955-0988
9	A21 SLODA (Switched LO Distribution Amplifier)	5087-7700
10	FL2 Band Pass Filter, 3.9214 GHz	0955-1074
11	RF Frame	E4440-20165

Figure 10-6 YTO Assembly

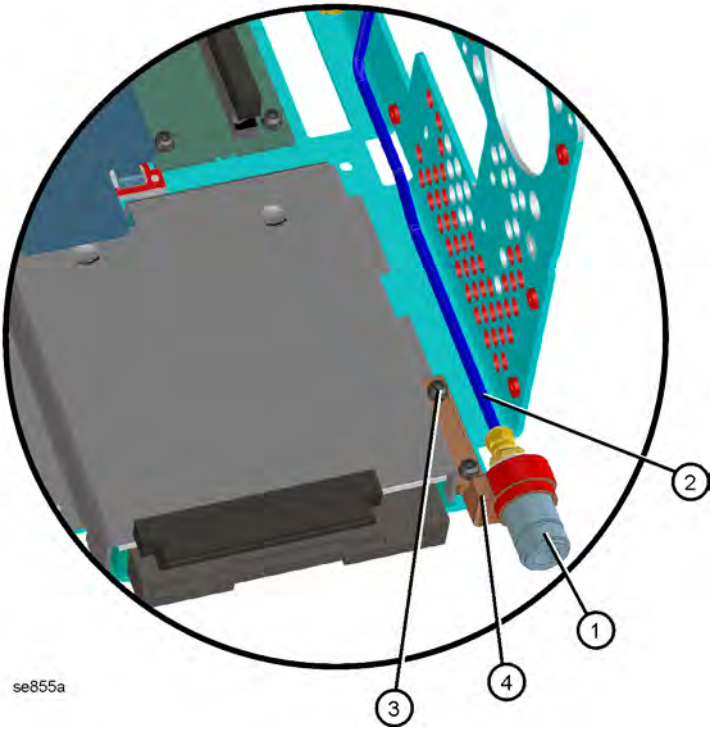


sn521a



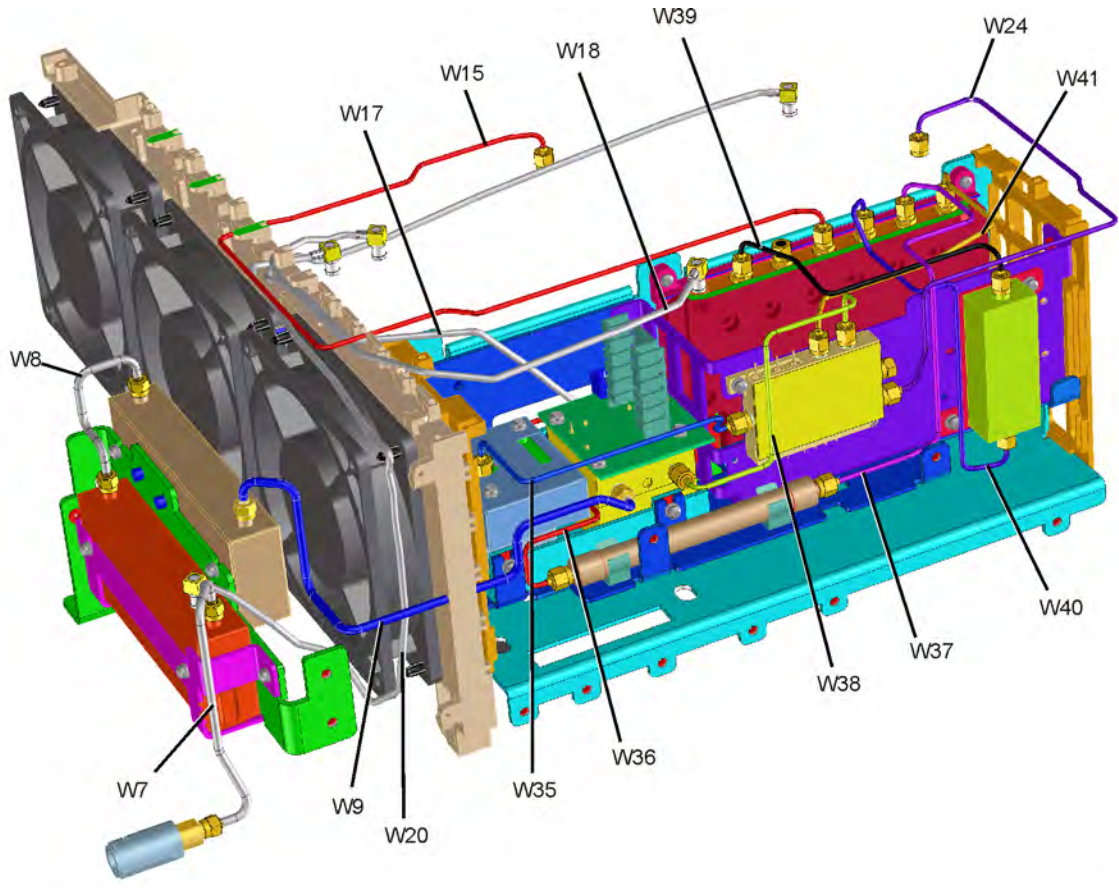
<b>Item</b>	<b>Description</b>	<b>Agilent Part Number</b>
1	Screw, M3 x 0.58 MM long	0515-0372
2	Lid, A18 YTO	E4440-00019
3	A18 YTO, 2.9 to 7 GHz (Yig Tuned Oscillator)	E4440-60023
4	Shield, A18 YTO	E4440-00018
5	Grommet, A18 YTO (2 each)	0400-0333
6	Shoulder Washers, A18 YTO (2 each)	5022-0179
7	Screw, A18 YTO Shield (2 each)	0515-0665

**Figure 10-7**      **RF Input Connector**  
**E4440A, E4443A, E4445A**



<b>Item</b>	<b>Description</b>	<b>Agilent Part Number</b>
1	J1 Input Connector, Type N J1 Input Connector, 3.5 mm (m) (Option BAB)	08559-60002 08673-60040
2	-W7 Cable, semi-rigid (with ferrites), For standard "N" type RF Input to A14 Attenuator -W7 Cable, semi-rigid, For Option BAB 3.5 APC RF Input to A14 Attenuator	E4440-20067 E4440-20099
3	Screw M3x0.5 8mm-LG (Crest Washer-Pan Head-TORX)	0515-0372
4	Bracket, Type N Input Bracket, 3.5 mm Input (Option BAB)	E4440-20185 E4440-20094

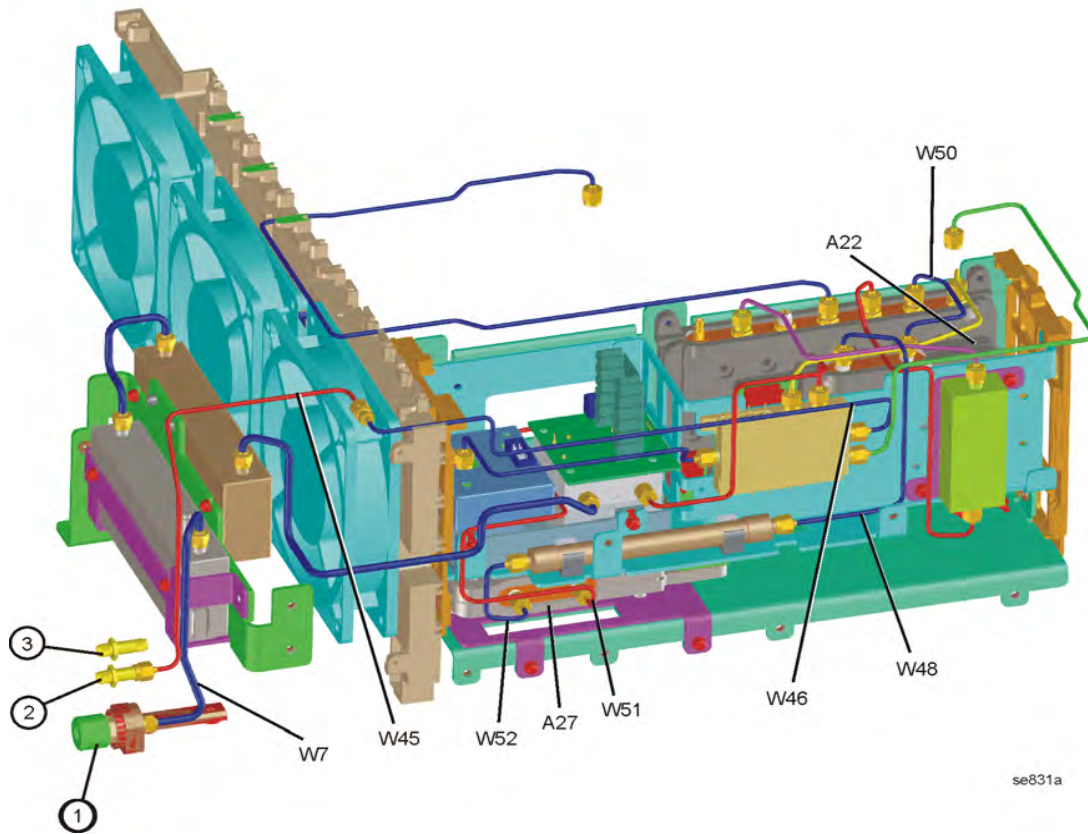
**Figure 10-8** RF Section Cables  
E4440A, E4443A, E4445A - Standard



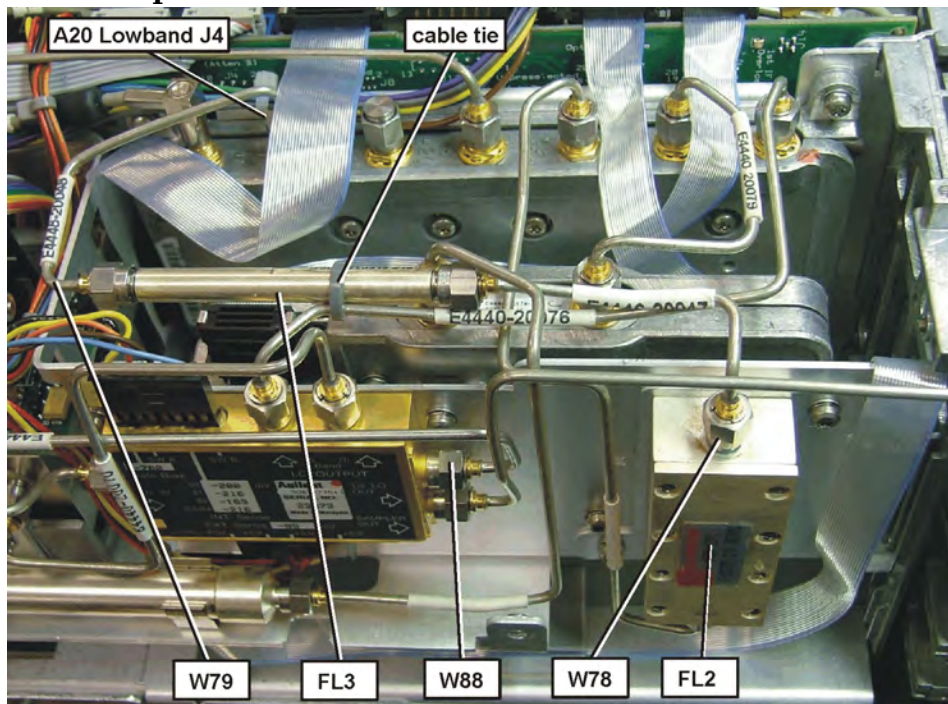
se830a

<b>Reference Designator</b>	<b>Description</b>	<b>Agilent Part Number</b>
W7	W7 Cable, semi-rigid (with ferrites), For standard "N" type RF Input to A14 Attenuator	E4440-20067
W8	W8 Cable, semi-rigid (with ferrites), A14 attenuator to A15 attenuator	E4440-20068
W9	W9 Cable, semi-rigid, A15 Attenuator to A19 RYTHM	E4440-20069
W15	W15 Cable, semi-rigid, A9 2nd LO, J10 to Lowband, J5	E4440-20084
W17	W17 Cable (10), coax (with ferrites), A19 RYTHM highband output to A10 3rd Converter J1	E4440-60371
W18	W18 Cable (7), coax (with ferrites), 321.4 MHz A20 Lowband assy to A10 3rd Converter J2	E4440-60372
W20	W20 Cable (50), coax, 50 MHz Cal signal from A10 3rd Converter J7 to A14 Attenuator	8121-0156
W24	W24 Cable, semi-rigid, A21 SLODA to A12 Synthesizer	E4440-20082
W35	W35 Cable, semi-rigid, YTO Output A18 YTO to A21 SLODA	E4440-20083
W36	W36 Cable, semi-rigid, A19 RYTHM to FL1 Low Pass Filter (except Option B7J)	E4440-20071
W37	W37 Cable, semi-rigid, FL1 Low Pass Filter to A20 Lowband Assy. J1 (except Option 1DS)	E4440-20074
W38	W38 Cable, semi-rigid, LO signal A21 SLODA to A19 RYTHM	E4440-20070
W39	W39 Cable, semi-rigid, Bandpass Filter Output, 3.9 MHz Bandpass Filter to A20 Lowband J4	E4440-20081
W40	W40 Cable, semi-rigid, Bandpass Filter Input, A20 Lowband J3 to FL2, 3.9 MHz Bandpass	E4440-20080
W41	W41 Cable, semi-rigid, A21 SLODA to A20 Lowband Assy.	E4440-20076

**Figure 10-9 RF Section and Cables**  
**E4440A, E4443A, E4445A - (Options 1DS, BAB, B7J, and AYZ)**



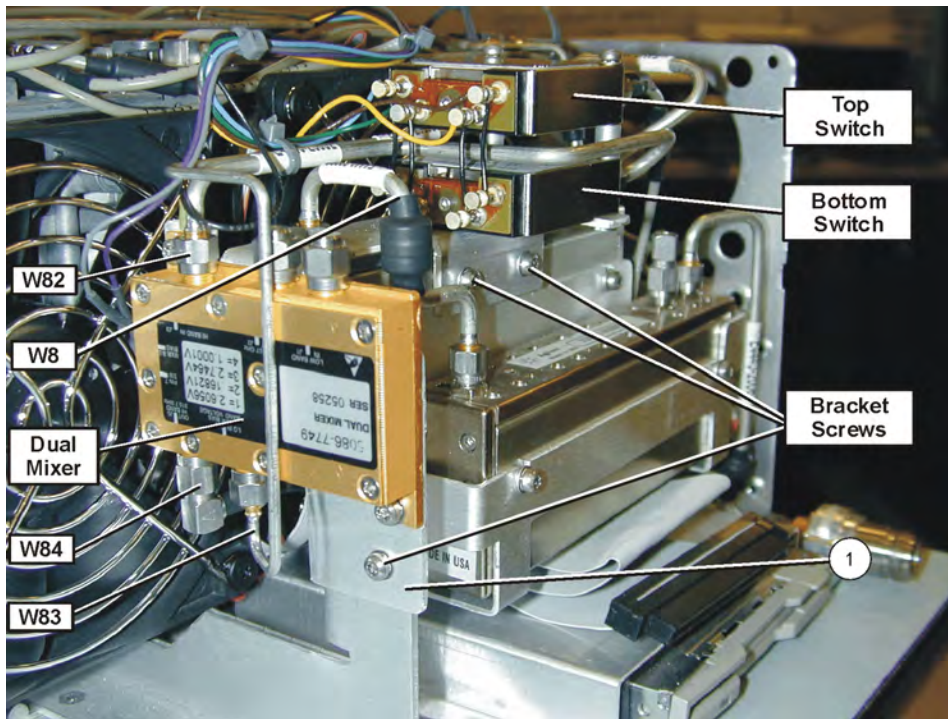
**Figure 10-10 Option 122 or 140 RF Cable Locations**



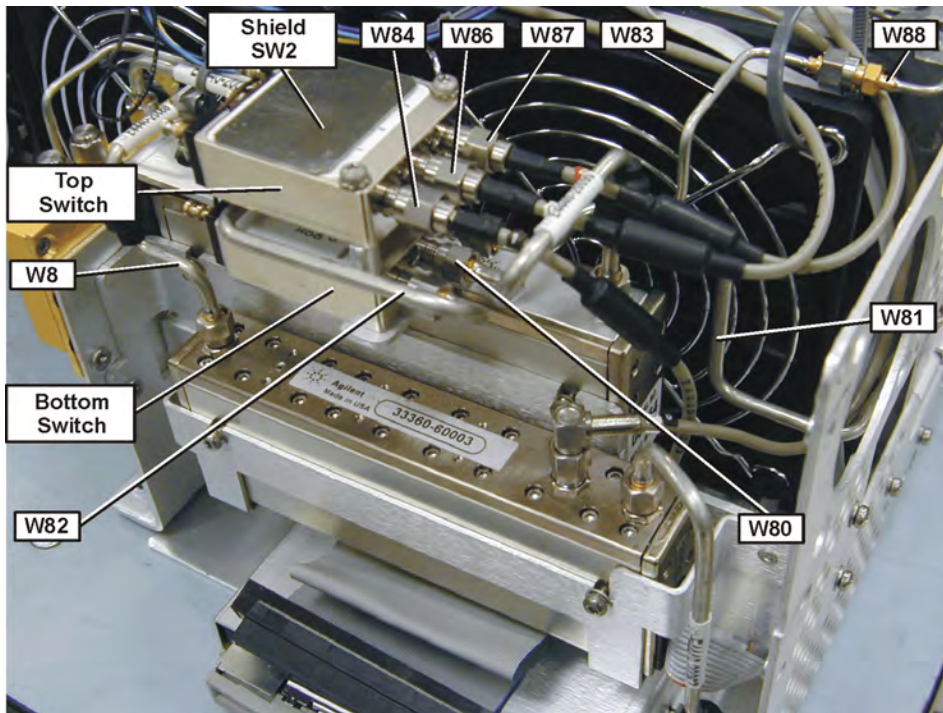
This table corresponds to [Figure 10-9](#) and [Figure 10-10](#).

<b>Reference Designator</b>	<b>Description</b>	<b>Agilent Part Number</b>
1	J1 Input Connector, 3.5 mm (m) (Option BAB)	08673-60040
2	1st LO OUT connector SMA (Option AYZ)	1250-1666
3	IF INPUT connector SMA (Option AYZ)	1250-1666
A22	A22 Preamp Assembly (Option 1DS)	E4440-60444
A27	A27 Electronic Attenuator (Option B7J)	E4440-60456
FL2	FL2 Band Pass Filter, 3.900 GHz (Option 122 or 140)	0955-1391
FL3	FL3 Low Pass Filter, 4.4 GHz (Option 122 or 140)	0955-0519
W7	W7 Cable, semi-rigid, For Option BAB 3.5 APC RF Input to A14 Attenuator	E4440-20099
W45	W45 Cable, semi-rigid, LO OUT from front-panel to W46 (Option AYZ)	E4440-20095
W46	W46 Cable, semi-rigid, LO OUT extension cable from A21 SLODA 1st LO OUT to W45. (Option AYZ, for PSA $\leq$ 26.5 GHz)	E4440-20087
W48	W48 Cable, semi-rigid, FL1 Low Pass Filter to A22 Preamp Assy. (Option 1DS)	E4440-20072
W50	W50 Cable, semi-rigid, Preamp Out from A22 Preamp to Lowband (Option 1DS)	E4440-20079
W51	W51 Cable, semi-rigid, A19 SBTX/Rythm out to A27 Electronic Attenuator (Option B7J)	E4440-20110
W52	W52 Cable, semi-rigid, A27 electronic attenuator to FL1, 3 GHz Low Pass Filter (Option B7J)	E4440-20109
W78	W78 Cable, semi-rigid, FL2 to FL3 (Option 122 or 140)	E4446-20047
W79	W79 Cable, semi-rigid, FL3 to A20 Lowband (Option 122 or 140)	E4446-20048
W88	W88 Cable, semi-rigid, SLODA LO Out to cable W83 Mixer LO In (Option 123)	E4440-20087

**Figure 10-11** E4440A, E4443A, E4445A  
Option 123 Assemblies and Cable Locations



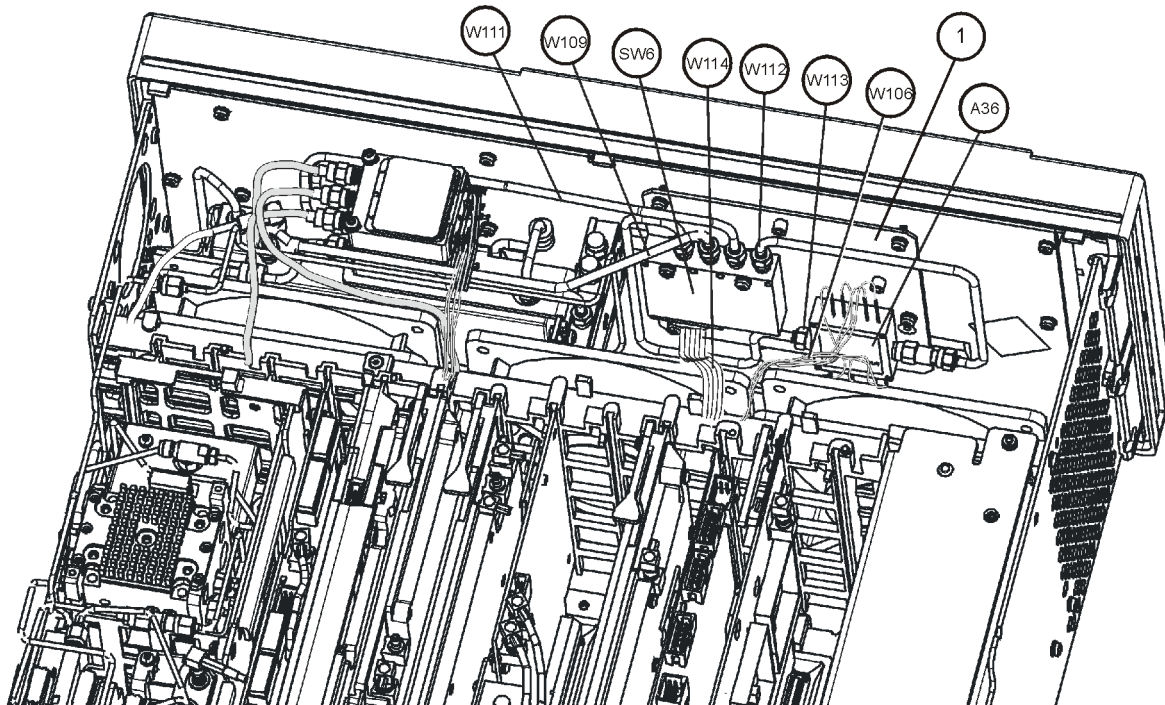
**Figure 10-12** E4440A, E4443A, E4445A  
Option 123 Assemblies and Cable Locations





<b>Reference Designator</b>	<b>Description</b>	<b>Agilent Part Number</b>
W8	W8 Cable, semi-rigid (with ferrites), A14 attenuator to A15 attenuator	E4440-20068
W80	W80 Cable, semi-rigid, Input Attenuator to Switch 1 (Option 123)	E4440-20090
W81	W81 Cable, semi-rigid (with ferrites), Switch 1 (bottom switch) port 2 to RYTHM input (Option 123)	E4440-20091
W82	W82 Cable, semi-rigid, Switch 1 (bottom switch) port 1 to Mixer input (Option 123)	E4440-20092
W83	W83 Cable, semi-rigid, Mixer LO IN to cable W88 from SLODA LO Out (Option 123)	E4440-20093
W84	W84 Cable (1), coax, Dual Mixer Out to Switch 2 (top switch) port 1 (Option 123)	E4440-60298
W86	W86 Cable (10), coax, 3rd Converter J1 to Switch 2 (top switch) port C (Option 123)	E4440-60373
W87	W87 Cable (2), coax, RYTHM t o Switch 2 (top switch) port 2 (Option 123)	E4440-60373
W88	W88 Cable, semi-rigid, SLODA LO Out to cable W83 Mixer LO In (Option 123)	E4440-20087
Dual Mixer	A34 Dual Mixer (Option 123)	5086-7749
Top Switch	SW2 RF Switch 2 Top Switch (Option 123) (must also order shield, SW2. see Mechanical Parts table	33314-60013
Bottom Switch	SW1 RF Switch 1 Bottom Switch (Option 123)	33314-60013
1	Bracket, Switch (Option 123)	E4440-00020
Shield	Shield, SW2 (Top Switch) (Option 123)	E4440-00055

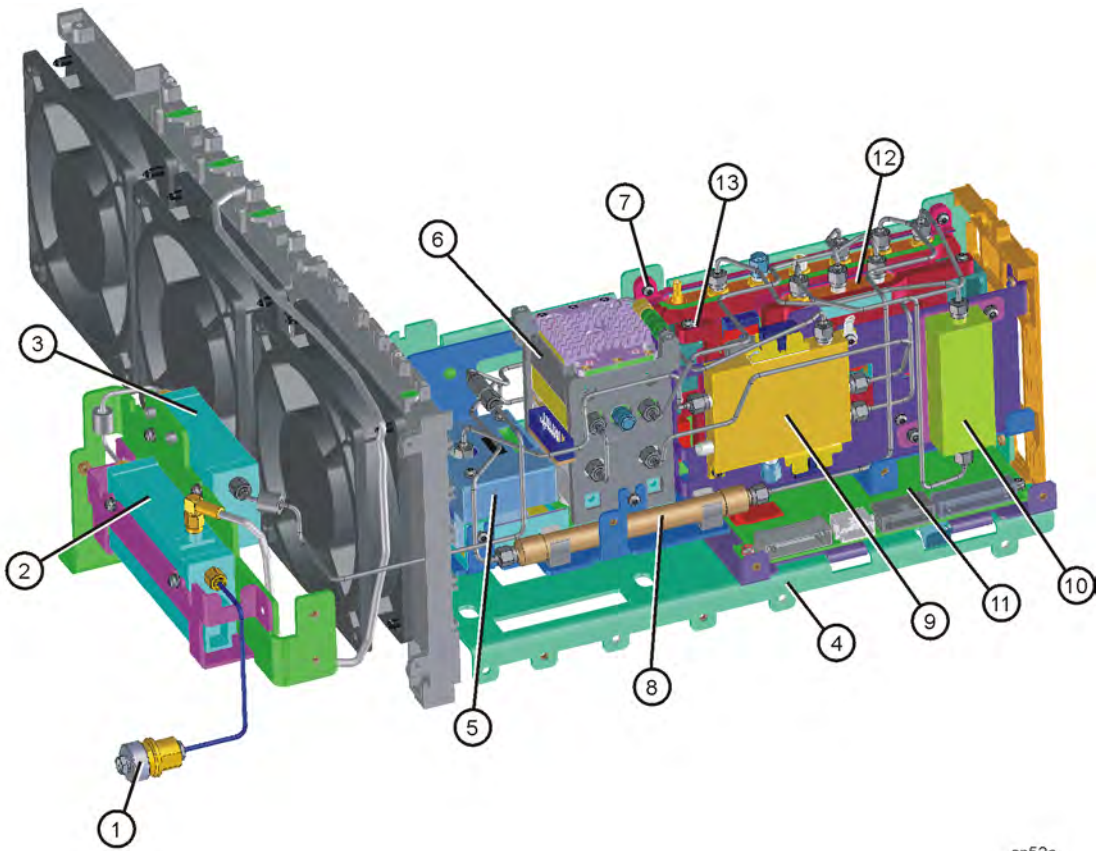
**Figure 10-13 E4440A, E4443A, E4445A - Option 110 (with Option 123)**



Reference Designator	Description	Agilent Part Number
A36	A36 Microwave Preamp 26.5 GHz (Option 110)	0955-1663
FL4 (not shown, attaches to SW1 port 1 and W115)	FL4 High Pass Filter, 3 GHz (Option 110 and 123 combination)	0955-1906
SW6	SW6 Switch, Microwave (Option 110)	N1811-60005
W106	W106, Wire Harness, Option Driver P1 to Preamp (Option 110)	E4446-60076
W109	W109, Cable semi-rigid A15 Attenuator to Switch 6 (Option 110 or Option 110 with Option 123)	E4440-20315
W111	W111, Cable, semi-rigid, Switch 6 to Option 123 Switch 1 Center Port (Opt 110 with Option 123)	E4440-20317
W112	W112, Cable, semi-rigid, Preamp Out from Switch 6 (Option 110)	E4440-20323
W113	W113, Cable, semi-rigid, Preamp In from Switch 6 (Option 110)	E4440-20304
W114	W114, Cable, ribbon, Switch Control, Option Driver Assy to SW 6 for Option 110	E4440-60427
1	Bracket, Switch/Preamp (Option 110)	E4440-00051



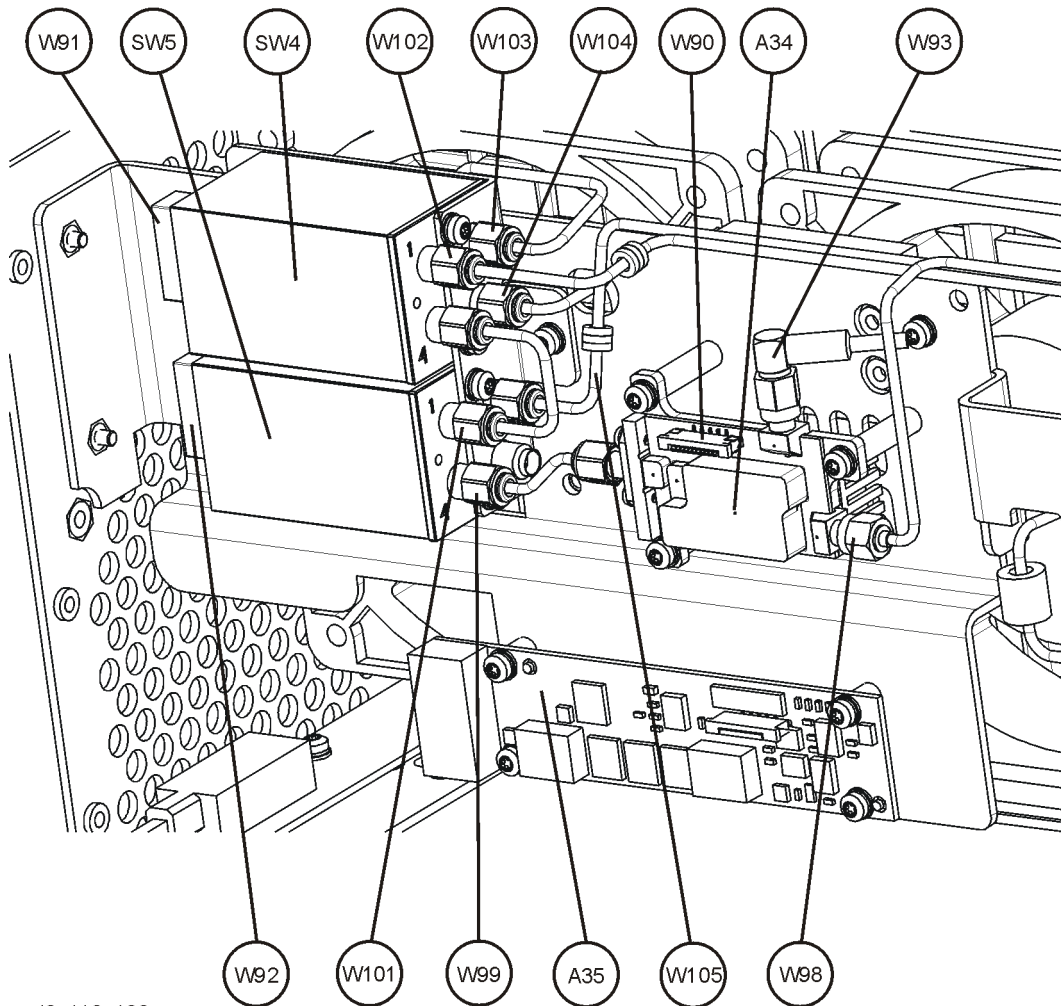
**Figure 10-14 RF Section**  
**E4446A, E4447A, E4448A - Standard**



sn52a

<b>Item</b>	<b>Description</b>	<b>Agilent Part Number</b>
1	J1 Input Connector, 2.4 mm	5064-3970
2	A14 Input Attenuator (10 dB)/Switch)	33326-60009
3	A15 Input Attenuator (60 dB)	33325-60009
4	L-bracket, RF Main	E4446-00003
5	A18 YTO, 2.9 to 7 GHz (Yig Tuned Oscillator)	E4440-60023
6	A19 SBTX/Rythm Assembly, 44 GHz	5087-7184
6	A19 SBTX/Rythm Assembly, 50 GHz	5087-7185
7	A20 Low Band Assembly	E4440-60217
8	FL1 Low Pass Filter, 3 GHz	0955-0988
9	A21 FELOMA (Frequency Extended LO Multiplying Amplifier)	5087-7126
10	FL2 Band Pass Filter, 3.9214 GHz	0955-1074
11	A29 SBTX Driver Board	E4446-60005
12	A30 FIFA, First IF Amplifier Assembly	E4446-60007
13	Bracket, FIFA/cable restraint for Lowband assembly (E4447A only)	E4447-60001

**Figure 10-15**      **Options 110 and 123**  
**E4446A, E4447A, E4448A**



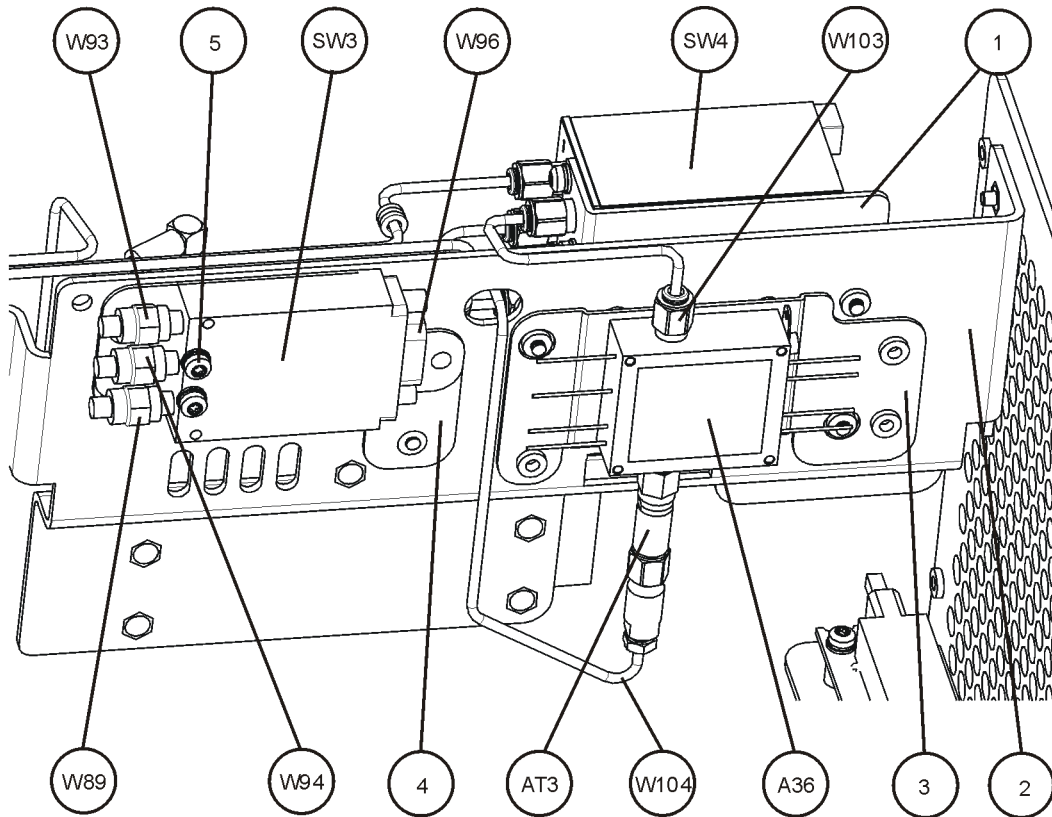
46\_110\_123

**NOTE**

See [Chapter 11, “Assembly Replacement Procedures,”](#) on page 305 of this service guide for views of Option 110 only or Option 123 only)

<b>Item</b>	<b>Description</b>	<b>Agilent Part Number</b>
A34	A34 Unpreselected mm-Wave Mixer (Option 123)	1NB7-8539
A35	A35 Mixer Bias Board (Option 123) (requires replacement of thermal pad, N1996-40018)	E4440-60254
SW4	SW4 Millimeter XFER Switch 50 GHz (top switch) (Option 110)	87222-60015
SW5	SW5 Switch, Millimeter (bottom switch) (Option 123)	87222-60015
W90	W90 Cable, Flat Flex, Unpreselected mixer to mixer bias board (Option 123)	8150-5698
W91	W91, Cable, ribbon, Switch Control, Option Driver Assy J3 to SW4 (top switch) (Option 110)	E4440-60455
W92	W92, Cable, ribbon, Switch Control Option Driver Assy J8 to SW5 (bottom switch) (Option 123)	E4440-60455
W93	W93, Cable, coax, Unpreselected mixer to Switch 3 coax switch top port (Option 123)	E4440-60298
W98	W98, Cable, semi-rigid, LO In to Unpreselected Mixer from W46/3 dB pad (Option 123)	E4446-20074
W99	W99, Cable, semi-rigid, Unpreselected mixer to switch 5 (bottom switch) Port 4 (Option 123)	E4446-20318
W101	W101, Cable, semi-rigid, Switch 4 port 4 to Switch 5 port 1 (Option 123, for combination of Option 110 with Option 123)	E4446-20081
W102	W102, Cable, semi-rigid, A15 Attenuator out to Switch 4 port 1 (Option 110)	E4446-20077
W103	W103, Cable, semi-rigid, Preamp In from Switch 4 port 2 (Option 110)	E4446-20078
W104	W104, Cable, semi-rigid, Preamp out to Switch 4 port 3 (Option 110)	E4446-20083
W105	W105, Cable, semi-rigid, Switch 5 port 2 to W34 cable to A10 RHYTHM/SBTX (Option 123)	E4446-20080

**Figure 10-16** Options 110 and 123  
E4446A, E4447A, E4448A (Rear View)



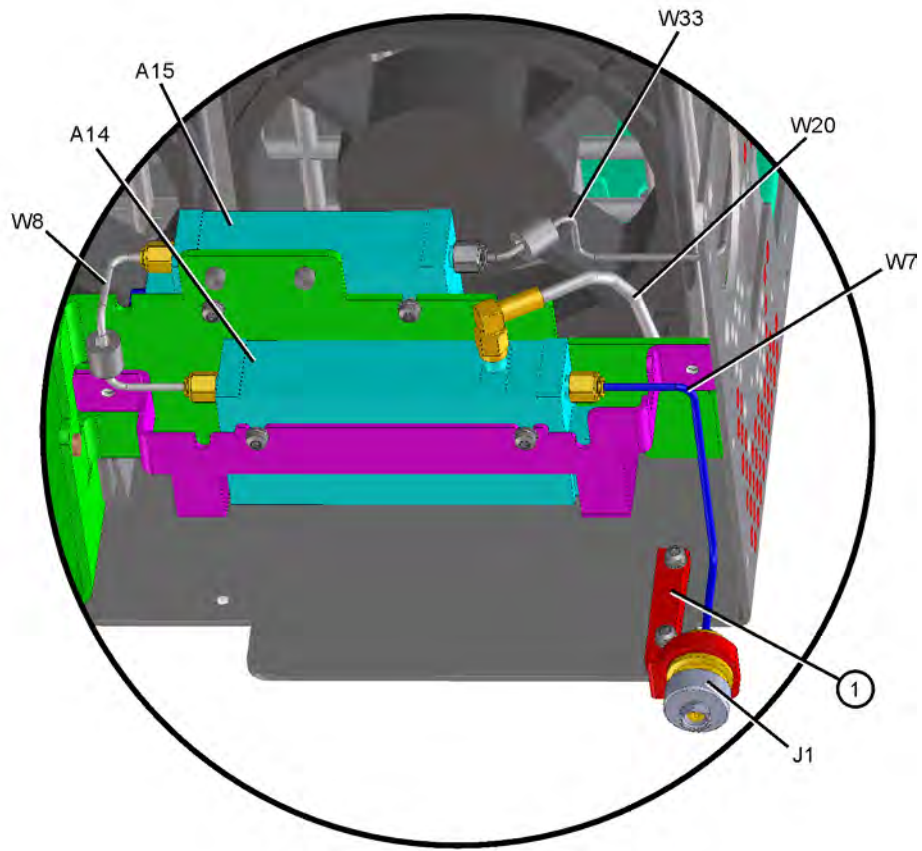
46\_110\_123\_rear

**NOTE** See [Chapter 11, “Assembly Replacement Procedures,”](#) on page 305 of this service guide for views of Option 110 only or Option 123 only)



<b>Item</b>	<b>Description</b>	<b>Agilent Part Number</b>
A36	A36 Millimeter Preamp 50 GHz (Option 110)	0955-1617
AT3	AT3 3 dB Attenuator (Option 110)	08490-60010
SW3	SW3 Coaxial Switch (Option 123)	N1810-60052
SW4	SW4 Millimeter XFER Switch 50 GHz (top switch) (Option 110)	87222-60015
W89	W89, Cable, coax, Switch 3 bottom port to RHYTHM/SBTX (Option 123)	E4440-60373
W93	W93, Cable, coax, Unpreselected mixer to Switch 3 coax switch top port (Option 123)	E4440-60298
W94	W94, Cable, coax, SW3 coax switch center connector to 3rd Converter (Option 123)	E4440-60373
W96	W96, Cable, ribbon, Driver board J9 to coax switch (Option 123)	E4440-60427
W103	W103, Cable, semi-rigid, Preamp In from Switch 4 port 2 (Option 110)	E4446-20078
W104	W104, Cable, semi-rigid, Preamp out to Switch 4 port 3 (Option 110)	E4446-20083
1	Bracket, Switch (Option 110, 123)	E4440-00063
2	Bracket, Unpreselected Mixer (Option 110, 123)	E4440-00062
3	Bracket, Preamp (Option 110)	E4440-00075
4	Bracket, Coax Switch (Option 123)	E4440-00076
5	Screw M3 X 0.5 16 MM (Option 123) Attaches SW3 to to bracket	0515-0375

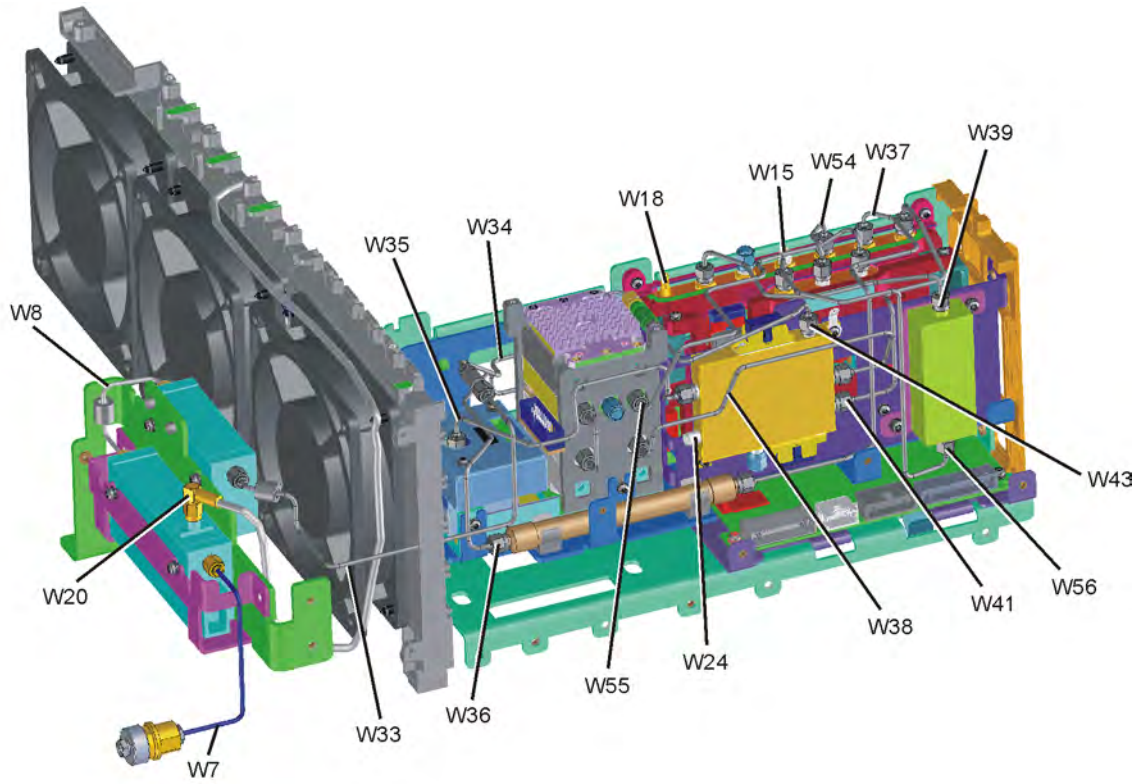
**Figure 10-17** RF Input Connector and Attenuators  
E4446A, E4447A, E4448A



sn54a

<b>Reference Designator</b>	<b>Description</b>	<b>Agilent Part Number</b>
1	Bracket, 2.4 mm RF Input	E4446-20004
J1	J1 Input Connector, 2.4 mm	5064-3970
W7	W7 Cable, semi-rigid, For standard 2.4mm RF Input to A14 Attenuator	E4446-20020
W8	W8 Cable, semi-rigid (with ferrites), A14 attenuator to A15 attenuator	E4446-20021
W20	W20 Cable (50), coax, 50 MHz Cal signal from A10 3rd Converter J7 to A14 Attenuator	8121-0156
W33	W33 Cable, semi-rigid, A15 Attenuator to W34	E4446-20022
A14	A14 Input Attenuator (10 dB)/Switch	33326-60009
A15	A15 Input Attenuator (60 dB)	33325-60009

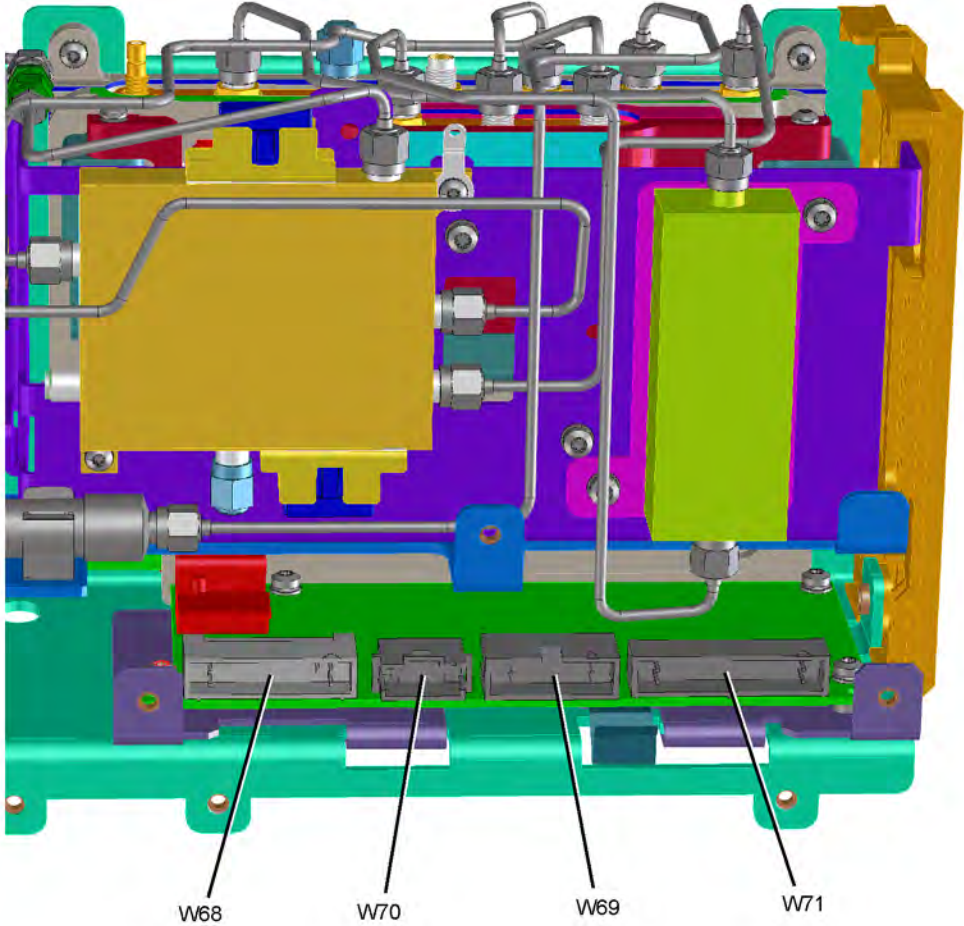
**Figure 10-18** RF Section Cable Locations  
E4446A, E4447A, E4448A - Standard



sn517a

<b>Reference Designator</b>	<b>Description</b>	<b>Agilent Part Number</b>
W7	W7 Cable, semi-rigid, For standard 2.4mm RF Input to A14 Attenuator	E4446-20020
W8	W8 Cable, semi-rigid (with ferrites), A14 attenuator to A15 attenuator	E4446-20021
W15	W15 Cable, semi-rigid, A9 2nd LO, J10 to Lowband, J5	E4440-20084
W18	W18 Cable (7), coax (with ferrites), 321.4 MHz A20 Lowband assy to A10 3rd Converter J2	E4440-60372
W20	W20 Cable (50), coax, 50 MHz Cal signal from A10 3rd Converter J7 to A14 Attenuator	8121-0156
W24	W24 Cable, semi-rigid, A21 FELOMA to A12 Synthesizer	E4446-20036
W33	W33 Cable, semi-rigid, A15 Attenuator to W34	E4446-20022
W34	W34 Cable, semi-rigid, W33 to A19 SBTX/RYTHM	E4446-20023
W35	W35 Cable, semi-rigid, YTO Output A18 YTO to A21 FELOMA	E4446-20033
W36	W36 Cable, semi-rigid, A19 SBTX/RYTHM to FL1 Low Pass Filter (except Option B7J)	E4446-20031
W37	W37 Cable, semi-rigid, FL1 Low Pass Filter to A20 Lowband Assy. J1 (except Option 1DS)	E4446-20037
W38	W38 Cable, semi-rigid, LO signal A21 FELOMA to A19 SBTX/RYTHM	E4446-20030
W39	W39 Cable, semi-rigid, Bandpass Filter Output, 3.9 MHz Bandpass Filter to A20 Lowband J4	E4446-20058
W41	W41 Cable, semi-rigid, A21 FELOMA to A20 Lowband Assy.	E4446-20034
W43	W43 Cable, semi-rigid, AT1 to FELOMA J2 (SBTX)	E4446-20049
W54	W54 Cable, semi-rigid, A20 Lowband J3 to FIFA middle connector	E4446-20044
W55	W55 Cable, semi-rigid, A19 SBTX to FIFA rear connector	E4446-20045
W56	W56 Cable, semi-rigid, FIFA to FL2 Band Pass filter	E4446-20046

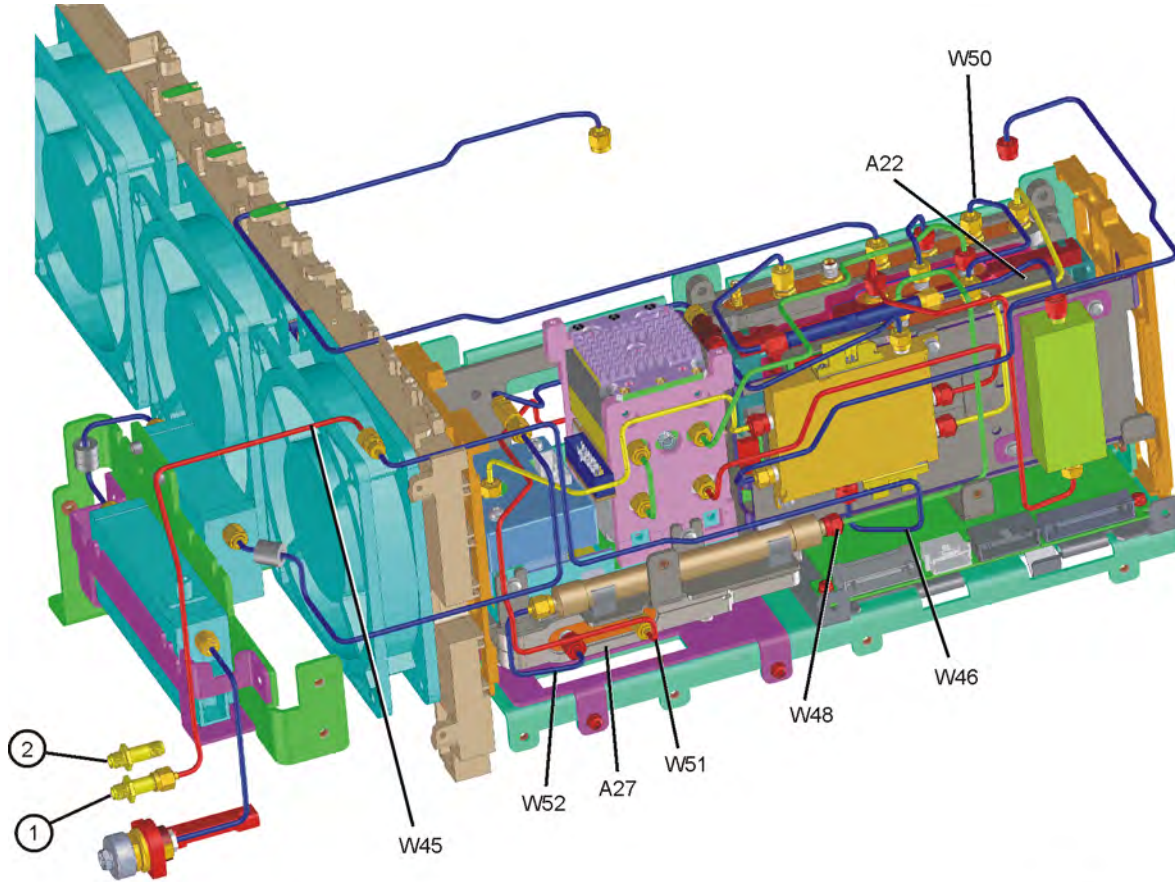
**Figure 10-19**     **SBTX Driver Board Ribbon Cable Locations**  
**E4446A, E4447A, E4448A**



sn518a

<b>Reference Designator</b>	<b>Description</b>	<b>Agilent Part Number</b>
W68	W68 Cable, ribbon, SBTX Tower Control, A29 SBTX Driver to A19 SBTX/Rythm	E4446-60008
W69	W69 Cable, ribbon, 20 pin, SBTX Digital Control, A29 SBTX Driver to A13 Front End Driver	E4446-60009
W70	W70 Cable, ribbon, 14 pin, SBTX Power, A29 SBTX Driver to A13 Front End Driver	E4446-60010
W71	W71 Cable, ribbon, FELOMA, A29 SBTX Driver to A21 FELOMA	E4446-60011

**Figure 10-20** RF Section Assembly and Cable Locations  
E4446A, E4447A, E4448A - (Options 1DS, B7J, and AYZ)

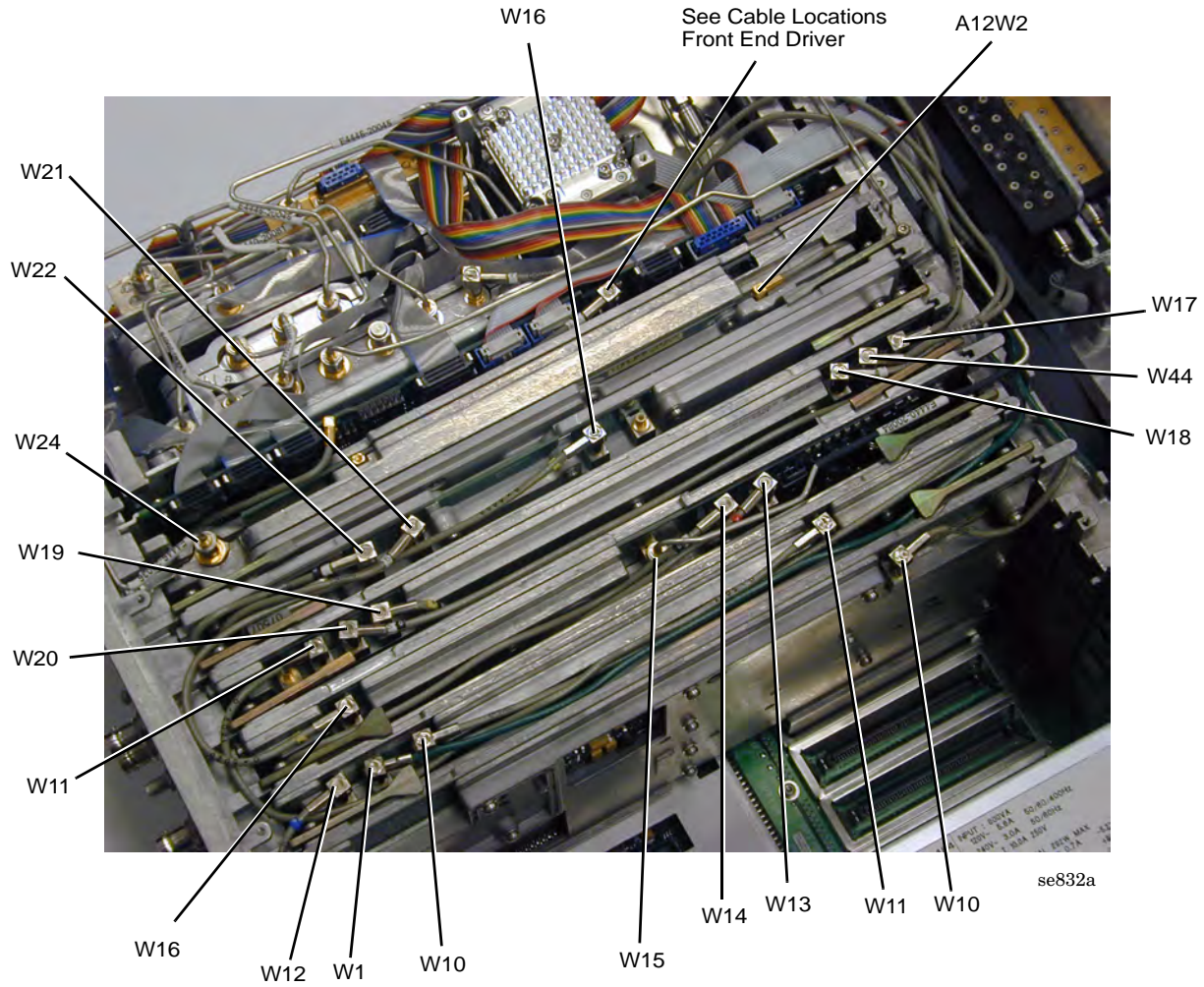


sn53a



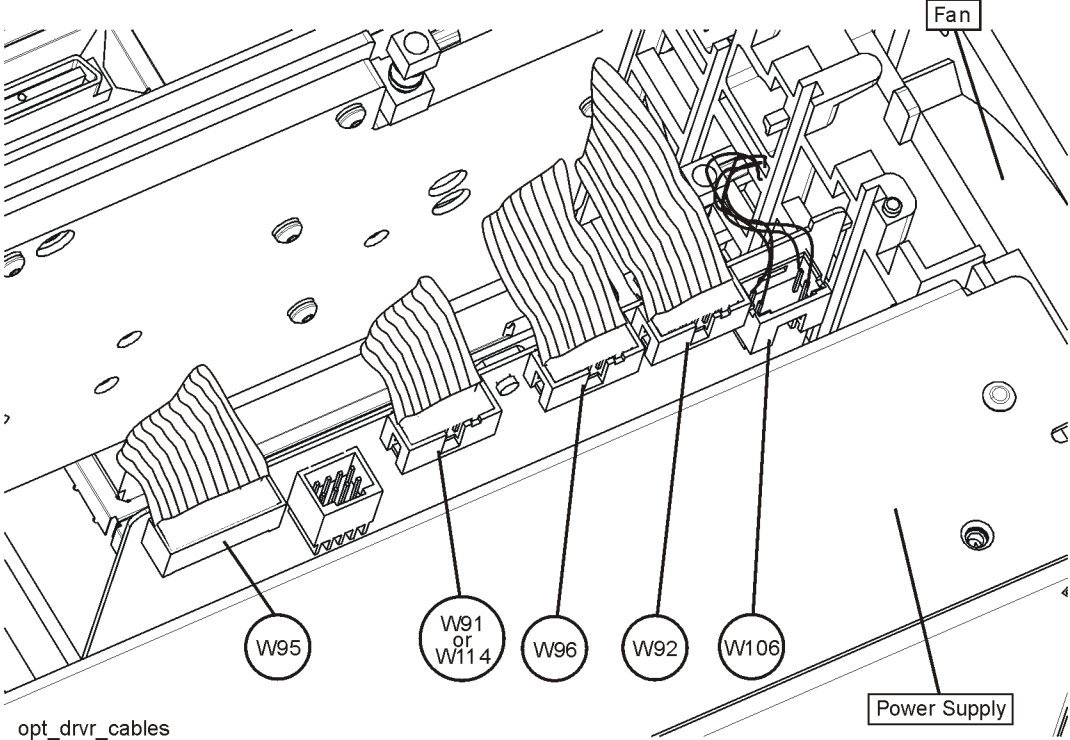
<b>Reference Designator</b>	<b>Description</b>	<b>Agilent Part Number</b>
1	1st LO OUT connector SMA (Option AYZ)	1250-1666
2	IF INPUT connector SMA (Option AYZ)	1250-1666
A22	A22 Preamp Assembly (Option 1DS)	E4440-60444
A27	A27 Electronic Attenuator (Option B7J)	E4440-60456
W45	W45 Cable, semi-rigid, LO OUT from front-panel to W46 (Option AYZ)	E4440-20095
W46	W46 Cable, semi-rigid, LO OUT extension cable from A21 FELOMA LO OUT to W45. (Option AYZ and 123, for PSA > 26.5 GHz)	E4446-20035
W48	W48 Cable, semi-rigid, FL1 Low Pass Filter to A22 Preamp Assy. (Option 1DS)	E4446-20038
W50	W50 Cable, semi-rigid, Preamp Out from A22 Preamp to Lowband (Option 1DS)	E4440-20079
W51	W51 Cable, semi-rigid, A19 SBTX/Rythm out to A27 Electronic Attenuator (Option B7J)	E4446-20039
W52	W52 Cable, semi-rigid, A27 electronic attenuator to FL1, 3 GHz Low Pass Filter (Option B7J)	E4446-20040

**Figure 10-21 Vertical Board Assembly Cables**



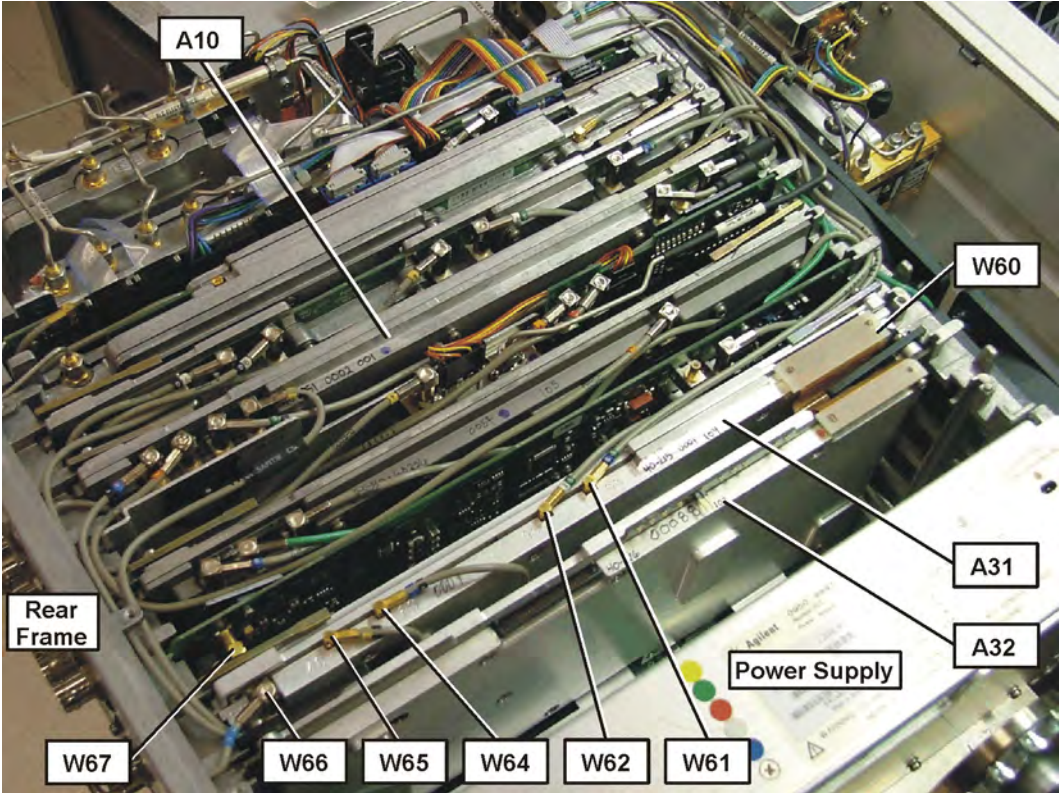
<b>Reference Designator</b>	<b>Description</b>	<b>Agilent Part Number</b>
W1	W1 Cable (5), coax, Front Panel External Trigger to A8 Analog IF Assy. P1	E4406-60139
W10	W10 Cable (8), coax, 7.5 MHz from A8 Analog IF P2, to A7 Digital IF, P1	8120-5022
W11	W11 Cable (3), coax, 21.4 MHz from A10 3rd Converter J5 to A8 Analog IF, J13	8120-5021
W12	W12 Cable (6), coax, TRIGGER IN from rear panel to A8 Analog IF, P4	8120-5053
W13	W13 Cable (20), coax, TRIGGER 1 OUT to A9 2nd LO, J12	8121-0153
W14	W14 Cable (30), coax, TRIGGER 2 OUT to A9 2nd LO, J11	8121-0153
W15	W15 Cable, semi-rigid, A9 2nd LO, J10 to Lowband, J5	E4440-20084
W16	W16 Cable (4), coax, 600 MHz from A11 Reference board P3 to A9 2nd LO, J1	8120-5022
W17	W17 Cable (10), coax (with ferrites), A19 RYTHM highband output to A10 3rd Converter J1	E4440-60371
W18	W18 Cable (7), coax (with ferrites), 321.4 MHz A20 Lowband assy to A10 3rd Converter J2	E4440-60372
W19	W19 Cable (40), coax 321.4 MHz IF OUT from A10 3rd Converter J4 to rear panel	8121-0149
W20	W20 Cable (50), coax, 50 MHz Cal signal from A10 3rd Converter J7 to A14 Attenuator	8121-0156
W21	W21 Cable (90), coax, 10 MHz Out from A11 Reference Assy P2 to rear panel	8120-5053
W22	W22 Cable (70), coax, Ext Ref In from rear panel to A11 Reference Assy P1	8120-5053
W24	W24 Cable, semi-rigid, A21 SLODA to A12 Synthesizer	E4440-20082
W44	W44 Cable (9), coax, IF IN from front-panel to A10 3rd Converter J3 (Option AYZ)	E4440-60374
A12W2	A12W2 Cable, MMCX coax, 600 MHz Ref (325 mm)	8121-0151

**Figure 10-22 Option Driver Board and Cables**



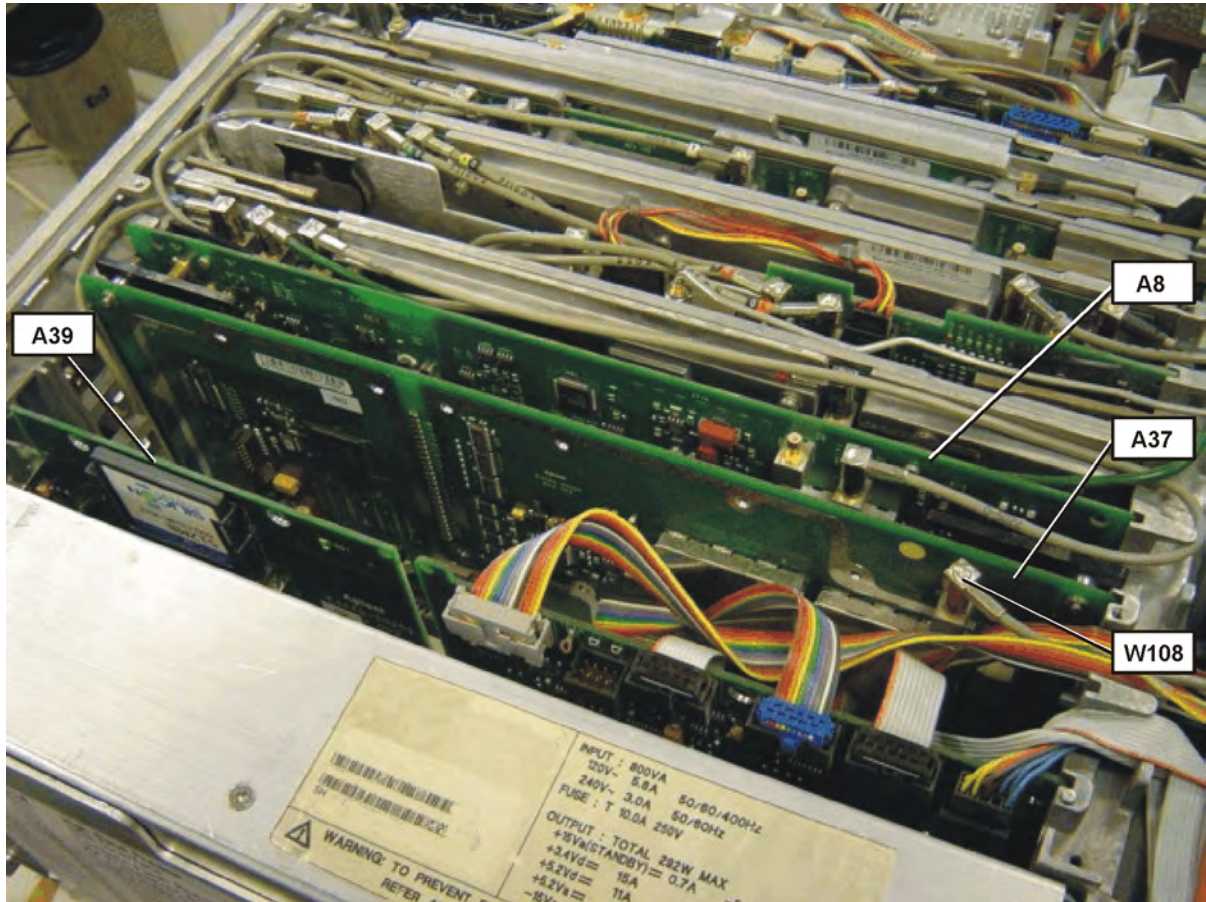
<b>Reference Designator</b>	<b>Description</b>	<b>Agilent Part Number</b>
W91	W91, Cable, ribbon, Switch Control, Option Driver Assy J3 to SW4 (top switch) (Option 110) (E4446A, E4447A, E4448A)	E4440-60455
W92	W92, Cable, ribbon, Switch Control Option Driver Assy J8 to SW5 (bottom switch) (Option 123)	E4440-60455
W95	W95, Cable, ribbon, Mixer Bias board control. Option Driver Assy J7 to Mixer Bias Board (Option 123)	E4440-60397
W96	W96, Cable, ribbon, Driver board J9 to coax switch (Option 123)	E4440-60427
W106	W106, Wire Harness, Option Driver P1 to Preamp (Option 110)	E4446-60076
W114	W114, Cable, ribbon, Switch Control, Option Driver Assy to SW 6 for Option 110 (Option 110, E4440A, E4443A, E4445A)	E4440-60427

**Figure 10-23** Option 122 or 140 Assembly and Cable Locations, and Option 124 W67 Cable Location



<b>Reference Designator</b>	<b>Description</b>	<b>Agilent Part Number</b>
A10	A10 3rd Converter Assembly	E4440-60261
A31	A31 Wideband Analog IF Assembly (Option 122 or 140)	E4440-60215
A32	A32 Wideband Digital IF Assembly (Option 122 or 140)	E4440-60262
W60	W60 Cable, ribbon, ADC Data from A31 WB Analog IF to A32 WB Digital IF (Option 122 or 140)	E4440-60341
W61	W61 Cable (65), coax, 100 MHz Ref from A11 Reference Assembly to A31 WB Analog IF (Option 122 or 140)	8121-1007
W62	W62 Cable (95), coax, 300 MHz Ref from A11 Reference Assembly P4 to A31 WB Analog IF (Option 122 or 140)	8120-8863
W64	W64 Cable (60), coax, WB IF CA:L from A31 WB Analog IF to A10 3rd Converter J6 (Option 122 or 140)	8121-1007
W65	W65 Cable (40), coax, 321.4 MHz IF from A10 3rd Converter J4 to A31 WB Analog IF (Option 122 or 140)	E4440-60343
W66	W66 Cable (66), coax, 321.4 MHz from A31 WB Analog IF to Rear Panel (Option 122 or 140)	8121-1323
W67	W67 Cable, coax, Video Out from Digital IF J100 to Rear Panel (Option 124)	8121-0964

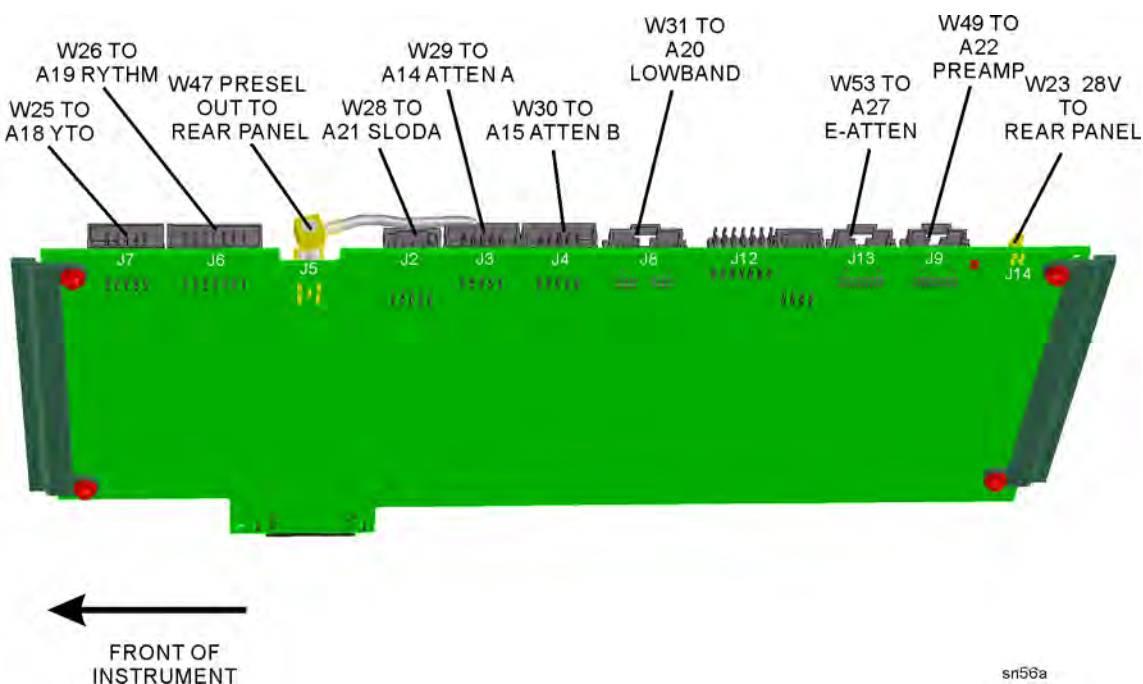
**Figure 10-24** Option 107 Audio Input Assembly and Cable Locations





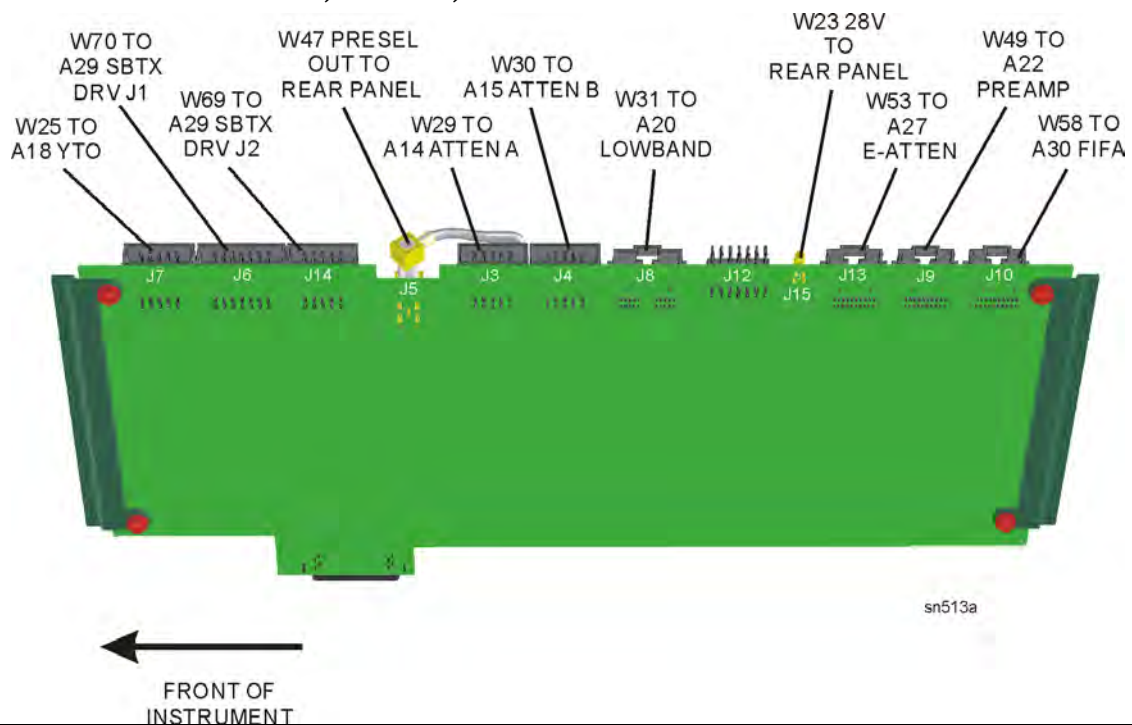
<b>Reference Designator</b>	<b>Description</b>	<b>Agilent Part Number</b>
A8	A8 Analog IF Assembly	E4440-60256
A37	A37 Audio Digitizer Assembly (Option 107)	E4440-60264
A39	A39 USB/Memory Board (cover plate not attached; includes memory card) (Option 111, 115, 117)	E4440-60252
W108	W108, Cable, coax, Front Panel Audio In to Audio Board Assy (Option 107)	8121-1432

**Figure 10-25 Cable Locations, Front End Driver  
 E4440A, E4443A, E4445A**



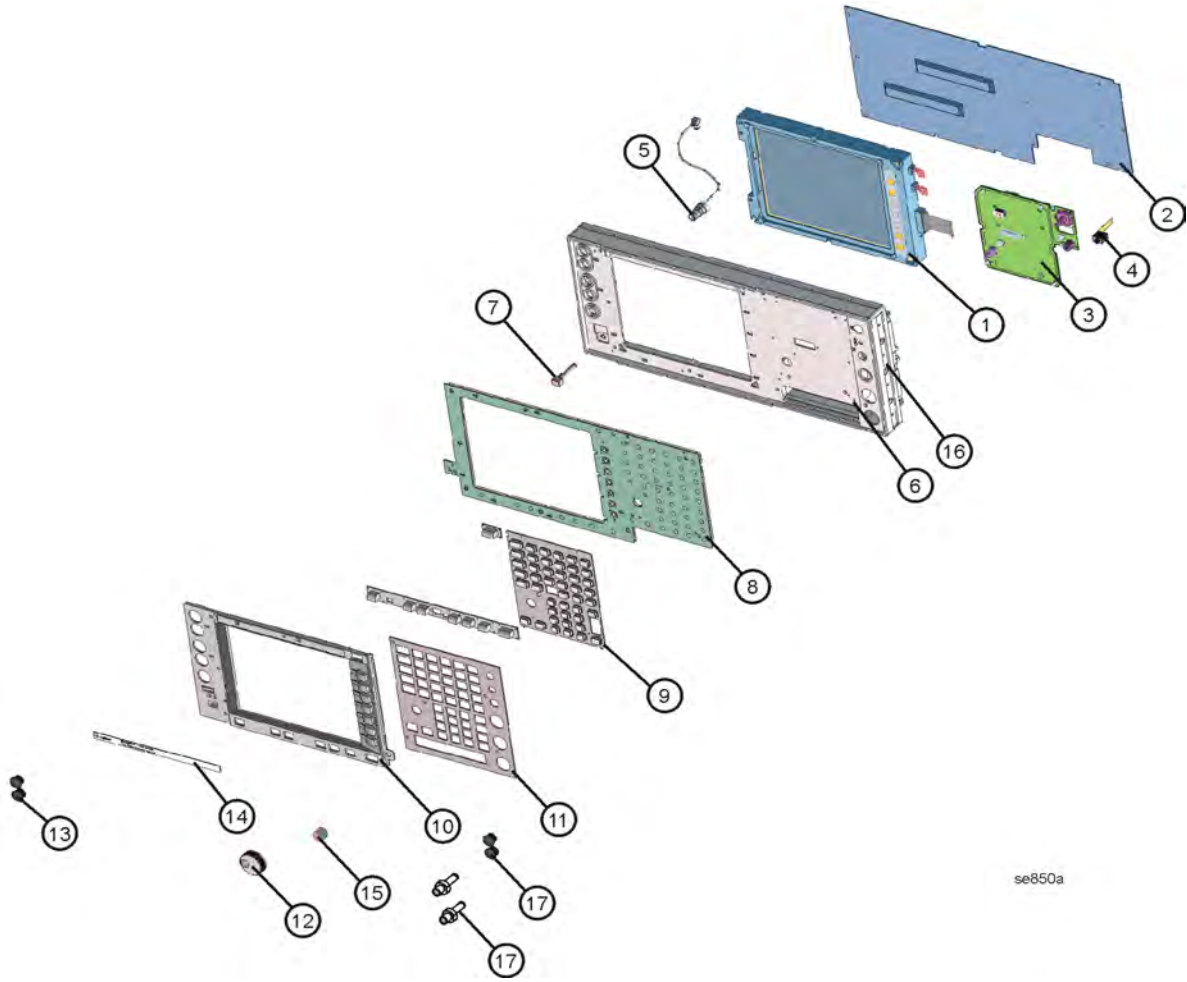
Reference Designator	Description	Agilent Part Number
W23	W23 Cable, coax, 28V to rear panel from A13 Front End Driver	8121-0958
W25	W25 Cable, ribbon, YTO Control	E4440-60069
W26	W26 Cable, ribbon, RYTHM Control	E4440-60070
W28	W28 Wire harness, SLODA control, from A13 Front End Driver to A21 SLODA	E4440-60067
W29	W29 Cable, ribbon, A13 Front End Driver to A14 Attenuator A	E4440-60071
W30	W30 Cable, ribbon, A13 Front End Driver to A15 Attenuator B	E4440-60071
W31	W31 Cable, ribbon, A13 Front End Driver to A20 Lowband Assy.	E4440-60072
W47	W47 Cable (97), coax, Preselector Tune Out A13 Front End Driver to Rear Panel	8121-0153
W49	W49 Cable, ribbon, Preamp control from A13 Front End Driver to A22 Preamp Assy. (Option 1DS)	E4440-60073
W53	W53 Cable ribbon, Electronic Attenuator control from A13 Front End Driver to A27 Electronic Attenuator (Option B7J)	E4440-60078

**Figure 10-26 Cable Locations, Front End Driver  
E4446A, E4447A, E4448A**



Reference Designator	Description	Agilent Part Number
W23	W23 Cable, coax, 28V to rear panel from A13 Front End Driver	8121-0958
W25	W25 Cable, ribbon, YTO Control	E4440-60069
W29	W29 Cable, ribbon, A13 Front End Driver to A14 Attenuator A	E4440-60071
W30	W30 Cable, ribbon, A13 Front End Driver to A15 Attenuator B	E4440-60071
W31	W31 Cable, ribbon, A13 Front End Driver to A20 Lowband Assy.	E4440-60072
W47	W47 Cable (97), coax, Preselector Tune Out A13 Front End Driver to Rear Panel	8121-0153
W49	W49 Cable, ribbon, Preamp control from A13 Front End Driver to A22 Preamp Assy. (Option 1DS)	E4440-60073
W53	W53 Cable ribbon, Electronic Attenuator control from A13 Front End Driver to A27 Electronic Attenuator (Option B7J)	E4440-60078
W58	W58 Cable, ribbon, A13 Front End Driver J10 to A30 FIFA	E4440-60073
W69	W69 Cable, ribbon, 20 pin, SBTX Digital Control, A29 SBTX Driver to A13 Front End Driver	E4446-60009
W70	W70 Cable, ribbon, 14 pin, SBTX Power, A29 SBTX Driver to A13 Front End Driver	E4446-60010

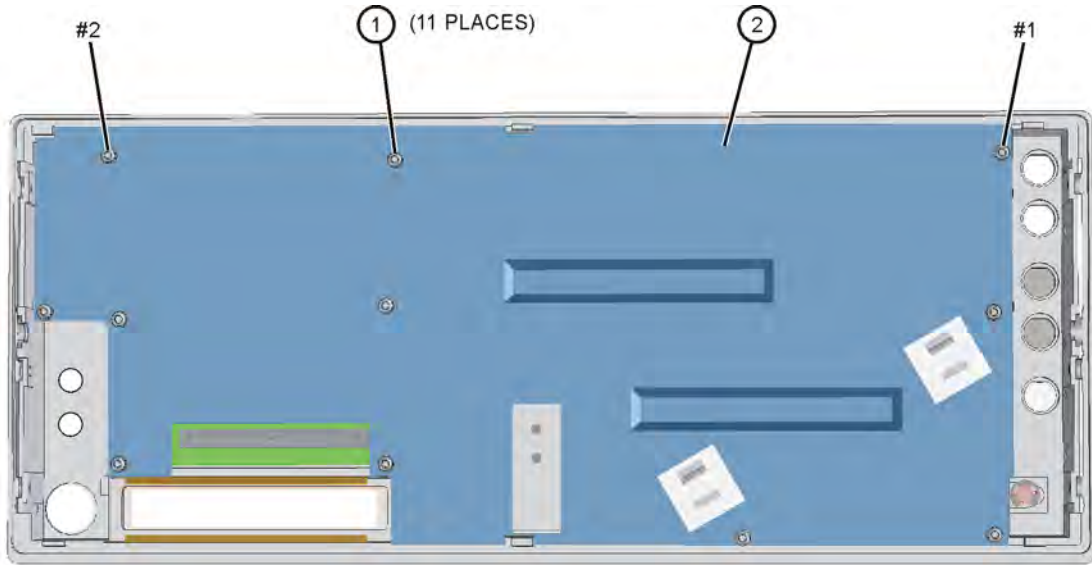
**Figure 10-27 Front Panel Parts**



se850a

<b>Item</b>	<b>Description</b>	<b>Agilent Part Number</b>
1	Display Assembly	(see Figure 10-29 and Figure 10-30)
2	Front Shield	E4440-00050
3	A2 Front Panel Interface (Includes Inverter Boards + cable)	E4440-63266
4	A28 Audio Out Board	E4406-60025
5	W1 Cable (5), coax, Front Panel External Trigger to A8 Analog IF Assy. P1	E4406-60139
6	Front Frame Assembly	E4406-60155
7	Line Key (push rod) Compression Spring Retainer Ring	E4406-40005 1460-2580 0510-1055C
8	A3 Keyboard Assembly (Key pad not included)	E4406-60004
9	Keypad	E4440-40003
10	Display Bezel Assembly (includes left overlay label, but does not include nameplate)	E4440-60081
11	Front Dress Panel (includes keyboard overlay label)	E4440-60080
12	RPG Knob	0370-3229
13	Plug, Hole 0.5D, Nylon (for BNC hole)	6960-0149
14	Name Plate, E4440A	E4440-80003
14	Name Plate, E4443A	E4443-80001
14	Name Plate, E4445A	E4445-80001
14	Name Plate, E4446A	E4446-80001
14	Name Plate, E4447A	E4447-80001
14	Name Plate, E4448A	E4448-80001
15	Volume Knob	0370-3230
16	Trim, side strips	5041-9172
17	Plug, Hole 0.25D, Nylon (for SMA hole)	6960-0076
17	SMA connectors (Option AYZ)	1250-1666

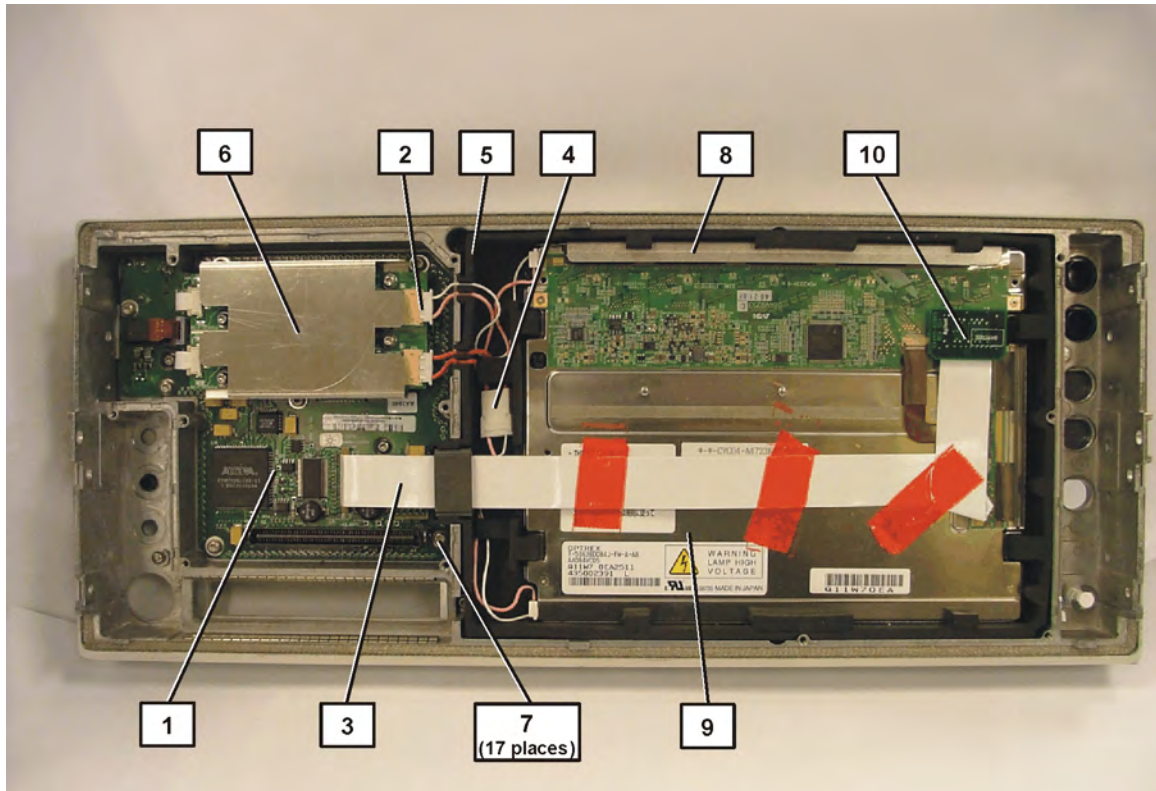
**Figure 10-28 Front Panel Shield Hardware**



se835a

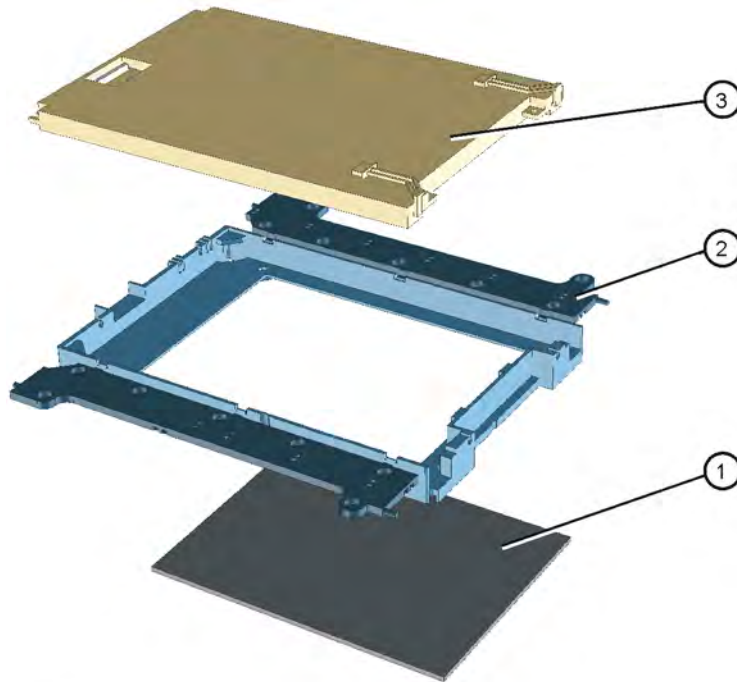
Item	Description	Agilent Part Number
1	Screw M3x0.5 8mm-LG (Crest Washer-Pan Head-TORX)	0515-0372
2	<a href="#">Front Shield</a>	<a href="#">E4440-00050</a>

**Figure 10-29 Front Panel Assemblies**



Item	Description	Agilent Part Number
1	A2 Front Panel Interface (Includes Inverter Boards + cable)	E4440-63266
2	A2A1 and A2A2 Inverter Boards (under Inverter Shield)	0950-3379
3	W5 Cable Flat flex, Front Panel Interface to display converter board (for serial prefix US/MY/SG 4611 and above)	8121-1419
4	W27 Cable, backlight extension (for serial prefix US/MY/SG 4644 and above)	8121-1420
5	Display Mount (serial prefix US/MY/SG 4611 and above)	E4406-40013
6	Shield, Inverter Board	E4440-00068
7	Screw M3x0.5 8mm-LG (Crest Washer-Pan Head-TORX)	0515-0372
8	Display Pressure Plate	E4406-00037
9	A1 Flat Panel Display (serial prefixes US/MY/SG 4611 and above) See Figure 10-29	2090-0897
10	A1A1 Display Converter Board	E4440-63265

**Figure 10-30**    **Display Parts**

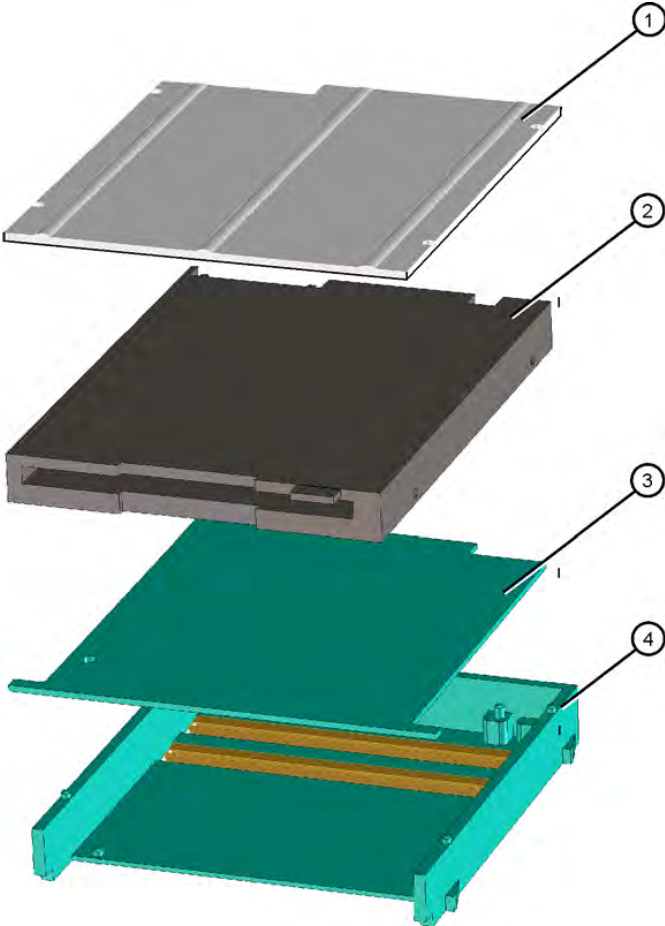


se847a

Item	Description	Agilent Part Number
1	Display EMI Filter	1000-1001
2	Display Mount (serial prefix US/MY/SG 4611 and above)	E4406-40013
3	A1 Flat Panel Display (serial prefixes US/MY/SG 4611 and above) See Figure 10-29	2090-0897



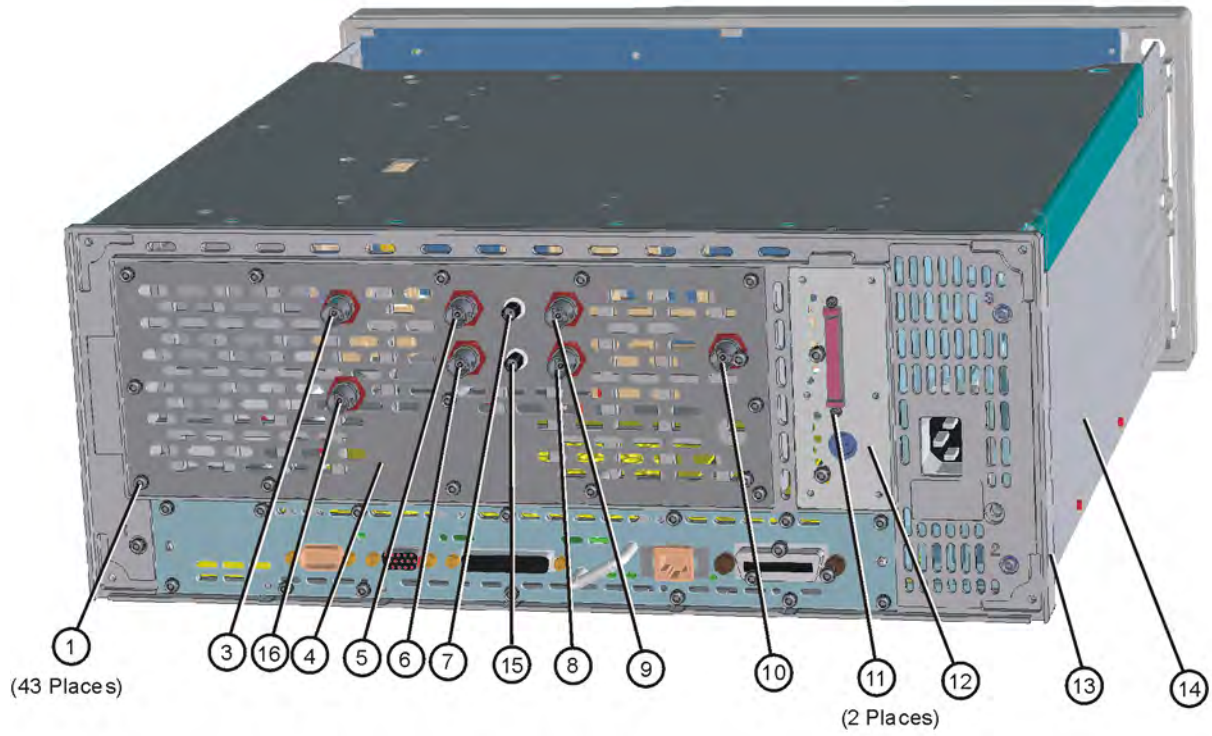
**Figure 10-31**     **Disk Drive Parts**



se837a

Item	Description	Agilent Part Number
1 and 4	Disk Drive Mount	E4406-40006
2	A23 Floppy Disk Drive	0950-2782
3	Disk Drive Board	E4406-60014

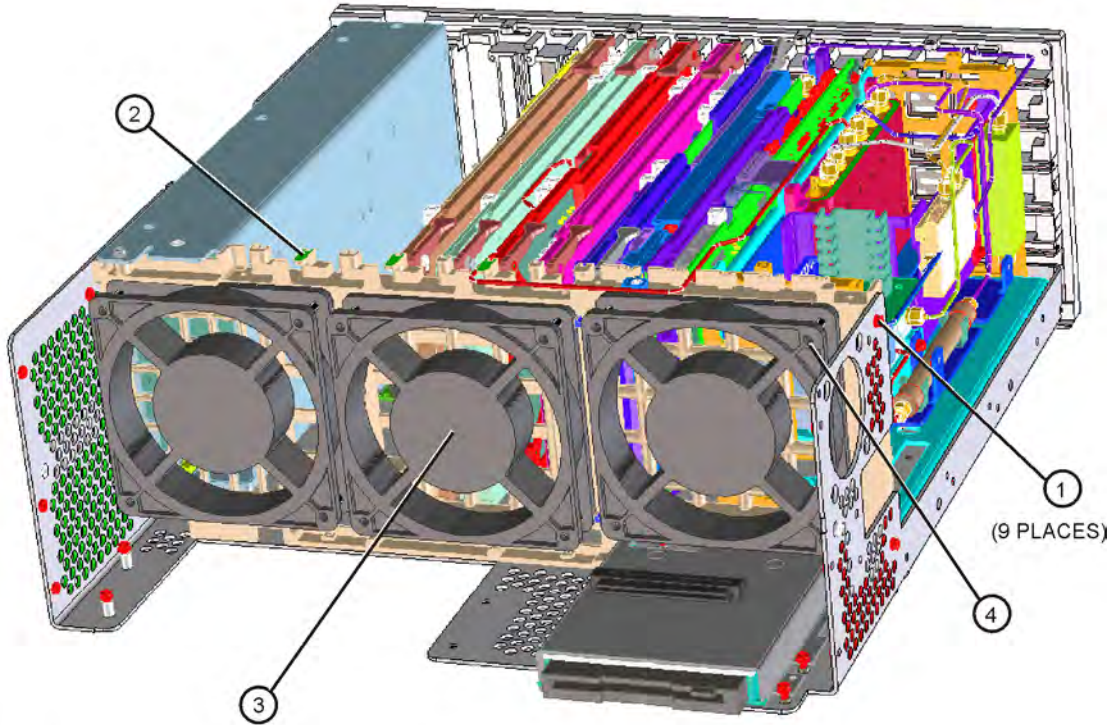
**Figure 10-32 Rear Frame Hardware**



se813a

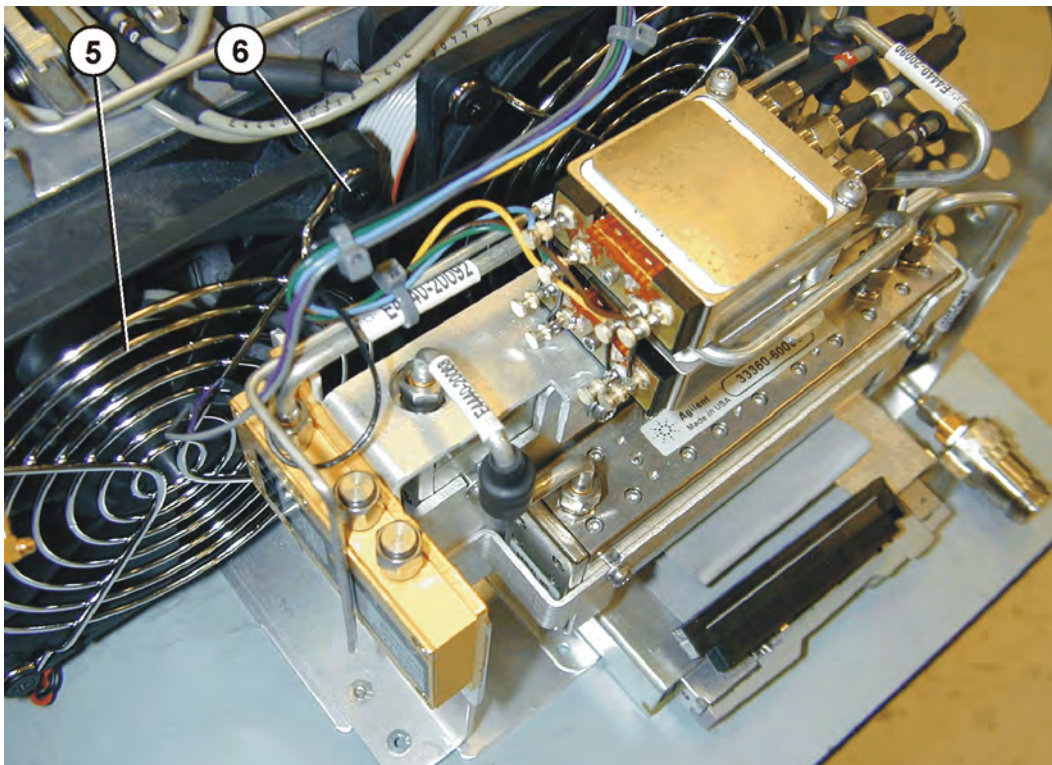
<b>Item</b>	<b>Description</b>	<b>Agilent Part Number</b>
1	Screw M3x0.5 8mm-LG (Crest Washer-Pan Head-TORX)	0515-0372
3	W47 Cable (97), coax, Preselector Tune Out A13 Front End Driver to Rear Panel	8121-0153
4	Dress Panel, rear	E4440-00059
5	W22 Cable (70), coax, Ext Ref In from rear panel to A11 Reference Assy P1	8120-5053
6	W21 Cable (90), coax, 10 MHz Out from A11 Reference Assy P2 to rear panel	8120-5053
7	W19 Cable (40), coax 321.4 MHz IF OUT from A10 3rd Converter J4 to rear panel	8121-0149
8	W14 Cable (30), coax, TRIGGER 2 OUT to A9 2nd LO, J11	8121-0153
9	W13 Cable (20), coax, TRIGGER 1 OUT to A9 2nd LO, J12	8121-0153
10	W12 Cable (6), coax, TRIGGER IN from rear panel to A8 Analog IF, P4	8120-5053
11	Screwlock, SCSI	1252-5828
12	Dress Panel, SCSI, shown in Figure 10-32	E4406-00017
12	Cover plate, rear panel, USB/Flash Board (Option 111, 115)	E4440-00061
13	Rear Frame Assy. (includes EMI gaskets)	E4406-60154
14	Deck Assy. (chassis)	E4440-00028
15	W75 Cable (41), coax, 70 MHz IF OUT, from A33 Option card J2 to rear panel (Option H70)	8121-0705
16	W23 Cable, coax, 28V to rear panel from A13 Front End Driver	8121-0958

**Figure 10-33 Mid Web Parts**



se88a

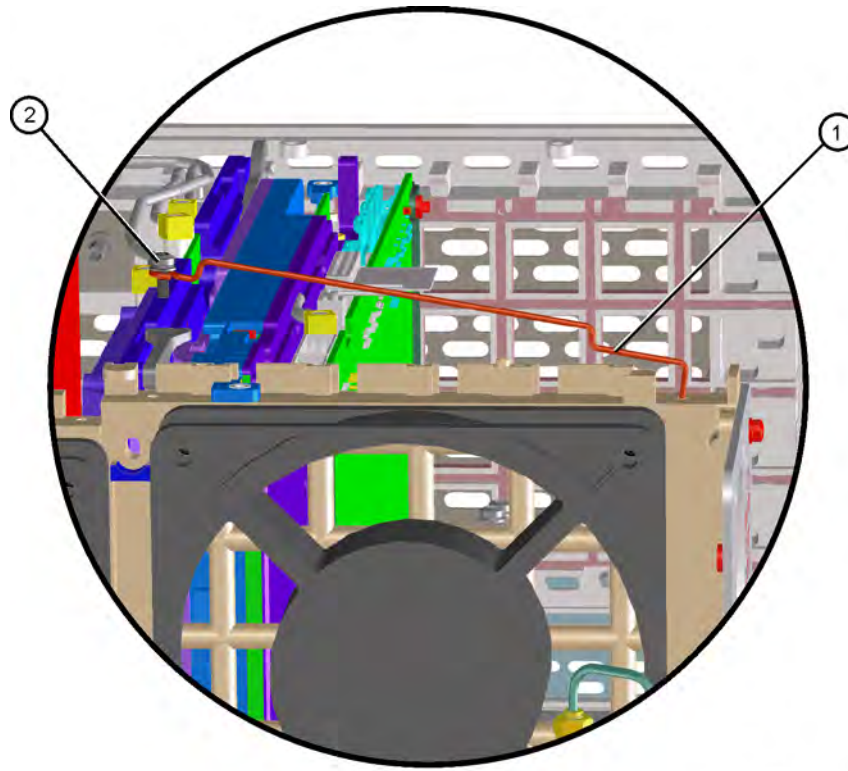
**Figure 10-34 Fan Guard**



This table corresponds to [Figure 10-33](#) and [Figure 10-34](#).

<b>Item</b>	<b>Description</b>	<b>Agilent Part Number</b>
1	Screw M3x0.5 8mm-LG (Crest Washer-Pan Head-TORX)	0515-0372
2	<a href="#">Mid Web</a>	<a href="#">E4406-20109</a>
3	<a href="#">B1, B2, or B3 Fan (fan, wires/connector + EMI disk)</a>	<a href="#">E4406-60159</a>
4	<a href="#">Rivet, fan mounting</a>	<a href="#">0361-1272</a>
5	<a href="#">Fan Guard</a>	<a href="#">3160-0281</a>
6	<a href="#">Rivet, fan guard mounting</a>	<a href="#">0361-1888</a>

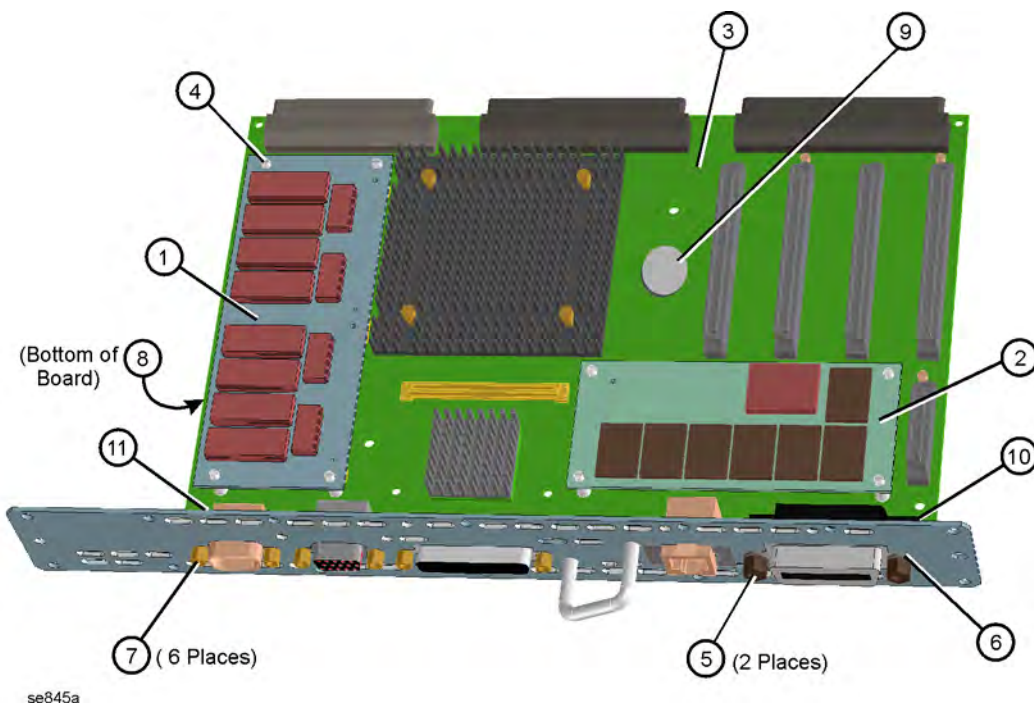
**Figure 10-35** Cable Hold Down



sn522a

Item	Description	Agilent Part Number
1	Cable hold down (on Midweb)	5022-6135
2	Screw M3x0.5 8mm-LG (Crest Washer-Pan Head-TORX)	0515-0372

**Figure 10-36 CPU Parts**



se845a

Item	Description	Agilent Part Number
1	A26A1 128M DRAM Assy (includes replacement standoffs)	E4406-60053
2	A26A2 64 MB Flash Memory Replacement Kit (includes replacement standoffs)	E4440-60094
3	A26 CPU (Processor) (includes standoffs; does not include A26A1 DRAM assy or A26A2 Flash Memory assy)	E4406-60060
4	Standoffs, Memory boards	0380-4163
5	Screwlock, GPIB .327 x 6-32	0380-0644
6	CPU Plate	not replaceable
7	Screwlock, 0.312 x 4-40	0380-1858
8	Nylon spacer .25 round (4 spacers keep the CPU from bending when vertical boards are inserted)	0380-4662
9	A26BTI Battery, Lithium Polycarbon Monofluoride (3V, 0.16AH Panasonic BR2325)	1420-0314
10	CPU shim	E4406-00079
11	CPU shim	E4406-00076





---

**11** **Assembly Replacement  
Procedures**

## What You Will Find in This Chapter

Procedures in this chapter enable you to locate, remove, and replace the major assemblies in your instrument.

Refer to [Chapter 10](#) , “Replaceable Parts Lists and Locations,” for part numbers, assembly descriptions, and ordering information.

This chapter contains removal and replacement procedures for the following:

- Outer Case.....page 310
- Top Brace .....page 312
- Front Frame ..... page 314
  
- RF Section and Assemblies (E4440A,E4443A,E4445A) ....page 317
  - A18 YTO and A19 RYTHM.....page 322
  - A21 SLODA .....page 323
  - FL1 Low Pass Filter.....page 323
  - FL2 Band Pass Filter.....page 324
  - A20 Lowband.....page 324
  - A22 Preamplifier .....page 326
  - A27 Electronic Attenuator.....page 326
  - A36 Preamplifier .....page 329
  
- RF Section and Assemblies (E4446A, E4447A, E4448A) ..page 336
  - A18 YTO and A19 SBTX/RYTHM.....page 341
  - A21 FELOMA.....page 342
  - FL1 Low Pass Filter.....page 342
  - FL2 Band Pass Filter.....page 343
  - A20 Lowband.....page 343
  - A29 LOMA/SBTX Driver .....page 345
  - A30 FIFA .....page 345
  - A22 Preamplifier .....page 347
  - A27 Electronic Attenuator.....page 347
  - SW4 Millimeter Switch.....page 351
  - A34 Mixer .....page 352
  - A35 Mixer Bias Board.....page 353
  - SW3 Switch .....page 353
  - SW5 Switch .....page 355
  
- A14 and A15 Attenuator Assembly.....page 357
- A5 Power Supply .....page 361
- A39 USB/Memory Board .....page 363
- A6 SCSI Board (early instruments).....page 366
- Vertical Board Assemblies .....page 366
- Mid-Web and Fan Assemblies .....page 374
- A23 Disk Drive .....page 378
- A25 Motherboard .....page 382

- A26 CPU Assembly .....page 385
- A26A1 DRAM and A26A2 Flash Boards .....page 388
- Rear Frame.....page 390
- RF Input Connector .....page 393
  
- Front Frame Subassemblies.....page 395
  - A1 LCD Display, Backlights, and Filter .....page 398
  - A2 Front Panel Interface Board .....page 402
  - Bezel and Keypad.....page 404
  - RPG.....page 407
  - External Trigger Cable .....page 407

---

**NOTE** Several PSA model numbers share the same circuit assemblies but require loading different memory initialization values for proper functionality. The assemblies that require memory initialization are listed in [Table 12-1](#) in [Chapter 12](#) .

---

## Before Starting

Before starting to disassemble the instrument:

- Check that you are familiar with the safety symbols marked on the instrument. And, read the general safety considerations and the safety note definitions given in the front of this guide.
- The instrument contains static sensitive components. Read the section entitled “[ESD Information](#)” on [page 19](#).

## Safety

---

**WARNING** **The opening of covers or removal of parts is likely to expose dangerous voltages. Disconnect the product from all voltage sources while it is being opened.**

---

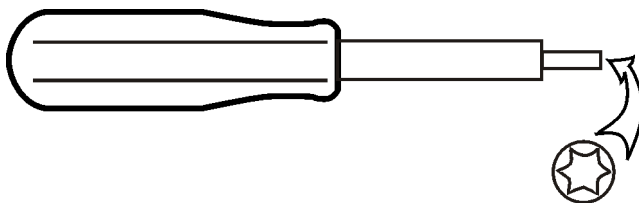
**WARNING** **The instrument contains potentially hazardous voltages. Refer to the safety symbols on the instrument and the general safety considerations at the beginning of this service guide before operating the unit with the cover removed. Failure to heed the safety precautions can result in severe or fatal injury.**

---

---

## Tools you will need

**Figure 11-1** TORX Tool



sl736a

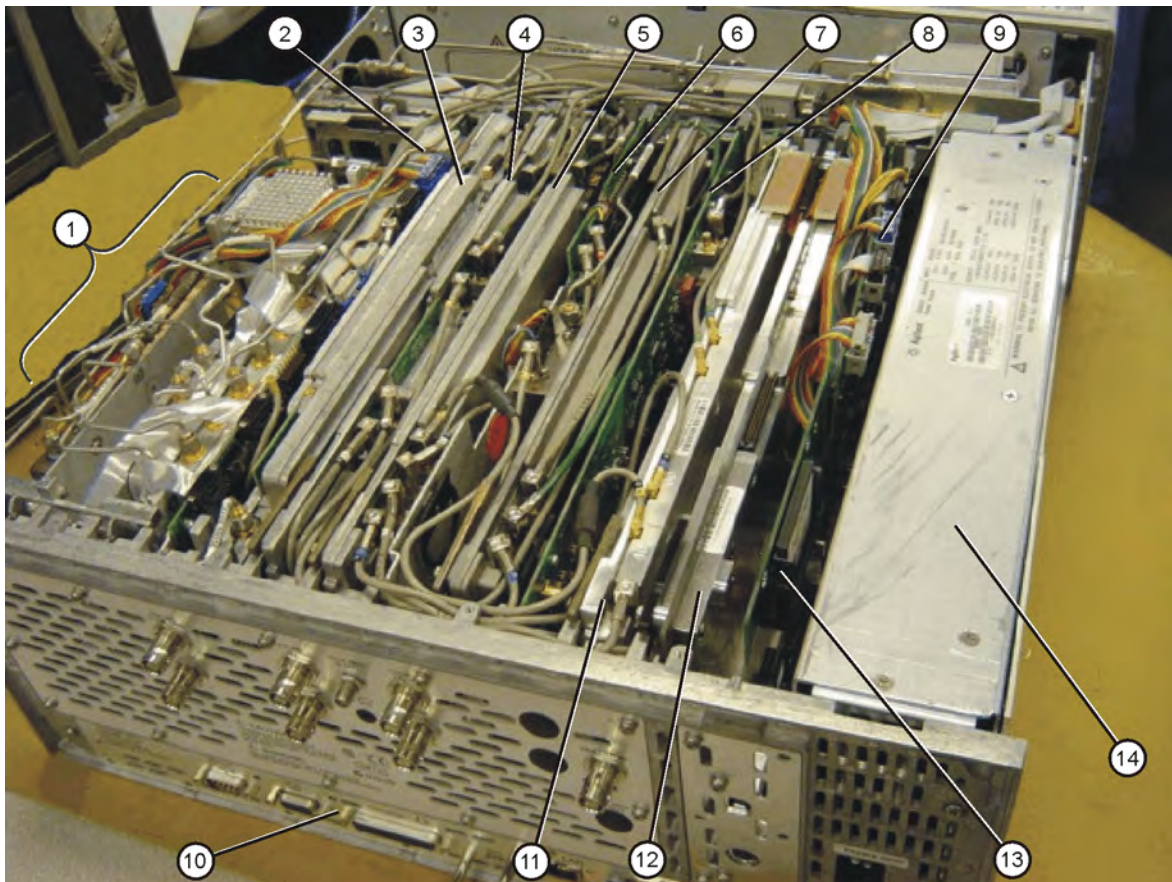
Description	Agilent Part Number
TORX Hand Driver - Size T10	8710-1623
TORX Hand Driver - Size T20	8710-1615
Pozidriv screwdriver - #1	8710-0899
flat blade screwdriver - 0.01 in. thick blade	8730-0008
9/16 inch nut driver	8720-0008
9/16 inch open-end wrench	8720-0010
5/16 inch open-end wrench (for SMA cables)	8720-0015
1/4 inch open-end wrench (for LO Out cable)	source locally
1/4 inch deep socket nut driver (for SMA connector mounting)	source locally
cable puller	5021-6773

### Adjustments after an instrument repair

[Table 12-1 on page 412](#). If one or more instrument assemblies have been repaired or replaced, perform the related adjustments and performance verification tests.

## Major Assembly Locations

Figure 11-2 Major Assemblies



Item	Description	Item	Description
1	RF Section	8	A7 Digital IF Assembly
2	A13 Front End Driver Board	9	A38 Option Driver Assembly (Option 110/123)
3	A12 LO Synthesizer Assembly	10	A26 CPU Assembly
4	A11 Reference Assembly	11	A31 Wideband Analog IF Assembly (Option 122 or 140)
5	A10 3rd Converter Assembly	12	A32 Wideband Digital IF Assembly (Option 122 or 140)
6	A9 2nd LO/ Fan Control Assembly	13	A39 USB/Memory Board
7	A8 Analog IF Assembly	14	A5 Power Supply

## Instrument Outer Case

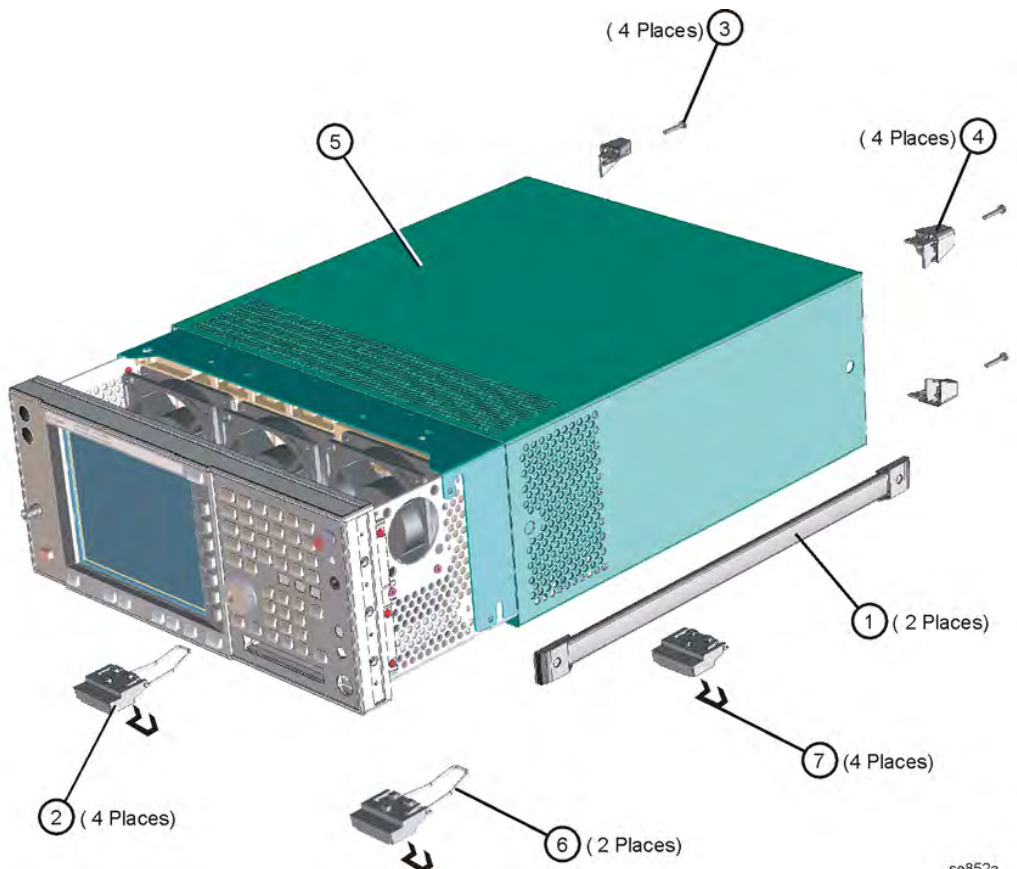
### CAUTION

If the instrument is placed on its face during any of the following procedures, be sure to use a soft surface or soft cloth to avoid damage to the front panel, keys, or input connector.

### Removal

1. Disconnect the instrument from ac power.
2. There are two handles on the sides of the instrument that must be taken off. Refer to [Figure 11-3](#). Using the T-20 driver, loosen the screws that attach each handle (1). Remove the handles.
3. Remove the four bottom feet (2). This is done by lifting up on the tabs on the feet, and sliding the feet in the direction indicated by the arrows.
4. Remove the four screws (3) that hold the rear feet (4) in place.
5. Pull the instrument cover (5) off towards the rear of the instrument.

**Figure 11-3 Instrument Outer Case Removal**



## Replacement

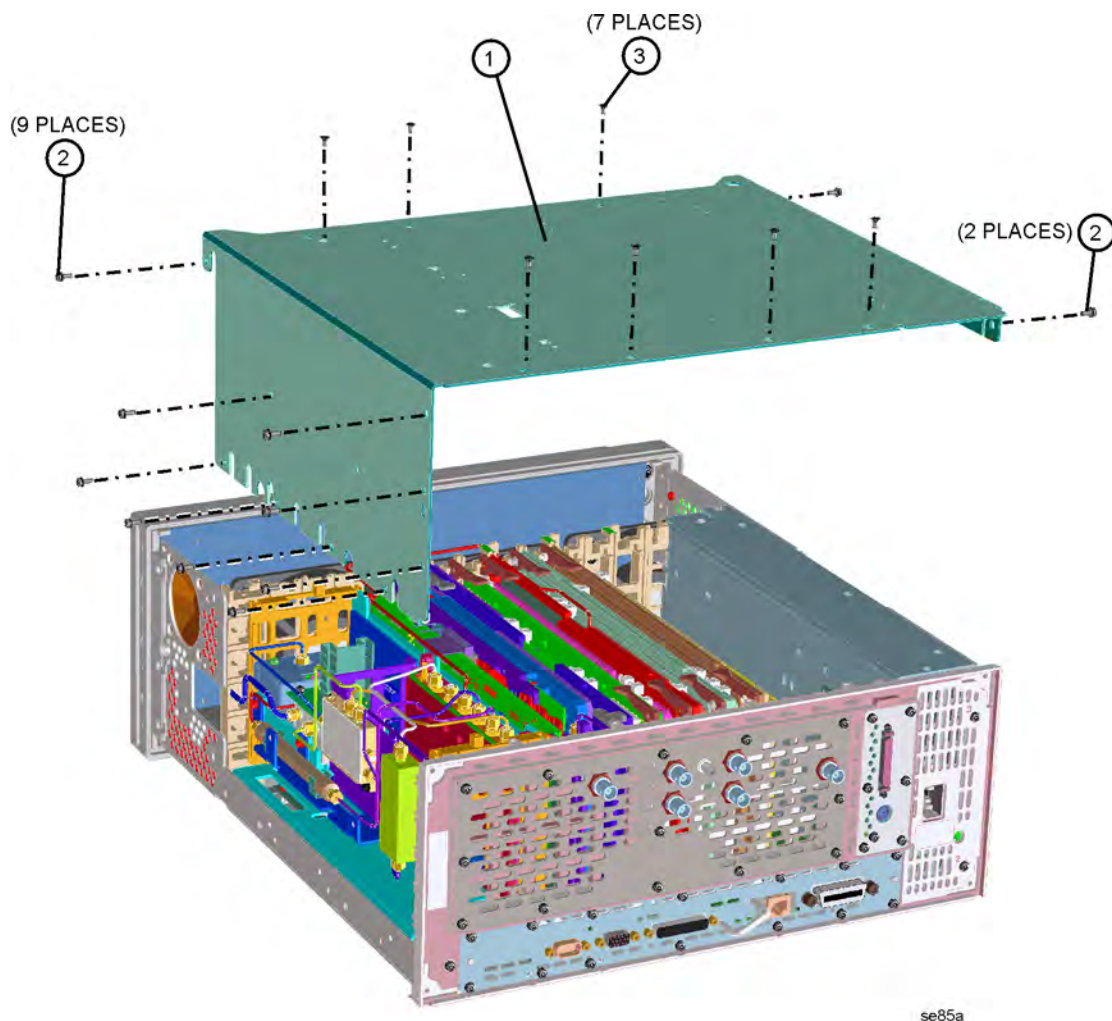
1. Disconnect the instrument from ac power.
2. Slide the instrument cover back onto the deck from the rear. The seam on the cover should be on the bottom. Be sure the cover seats into the gasket groove in the front frame.
3. Replace the four rear feet to the rear of the instrument. Torque to 21 inch pounds.
4. Using the T-20 driver, replace the handles. Torque to 21 inch pounds.
5. Replace the four bottom feet by pressing them into the holes in the case and sliding in the opposite direction of the arrows until they click into place. Note that the feet at the front have the tilt stands.

## Top Brace

### Removal

1. If you haven't already done so, remove the instrument outer case. Refer to the "Instrument Outer Case" removal procedure.
2. Using the T-10 driver, remove the top screws (3) (one screw is under the security label) and the side screws (2) attaching the top brace (1) to the deck. Refer to Figure 11-4.
3. The top brace can now be removed from the deck.

Figure 11-4 Top Brace





## Replacement

1. Carefully position the top brace on the deck. There is an alignment pin on the mid web/fan assembly that should match up with the alignment hole on the top brace. Make sure that no coaxial cables will get pinched underneath the brace.
2. Using the T-10 driver, replace the top screws first, and then the side screws after the top screws are tightened. Torque to 9 inch pounds.
3. Replace the outer case. Refer to the [“Instrument Outer Case”](#) replacement procedure.

## Front Frame

For most service situations, the front frame assembly can be “dropped” from the deck without disconnecting any cables. Refer to the section “[Drop the Front Frame](#)”. To completely remove the front frame, continue with the “[Removal](#)” section.

---

**CAUTION**

Use ESD precautions when performing this replacement procedure.

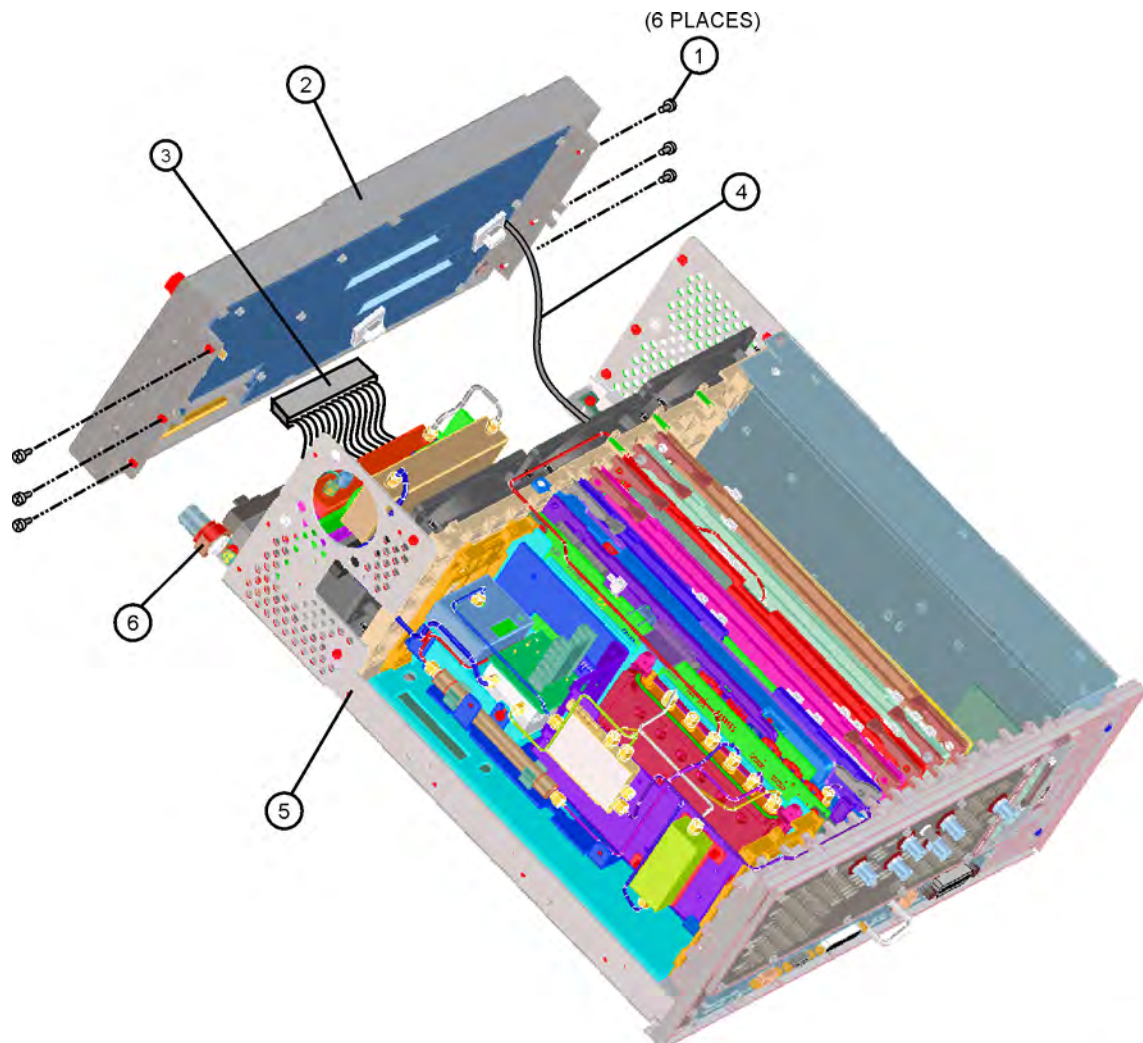
### Drop the Front Frame

1. Remove the instrument outer case. Refer to the “[Instrument Outer Case](#)” removal procedure.
2. Refer to [Figure 11-5](#). Using the T-10 driver, remove the 7 screws (1) that attach the front frame assembly (2) to the deck.
3. Pull the front frame off of the deck until it is disengaged from the disc drive.
4. At this point, the front frame can be placed flat on the bench for service while still attached to the instrument. If you want to completely remove the front frame, continue with the “[Removal](#)” section.

## Removal

1. Using a 9/16" socket drive, remove the nut securing the **Ext Trigger Input BNC connector**. Take care to not scratch the front dress panel.
2. Refer to [Figure 11-5](#). Disconnect the ribbon cable (3) from the A2 front panel interface board. Pull the coaxial cable (4) from the front frame and unclip from the two cable clamps.
3. Lift the front frame assembly away from the deck.

**Figure 11-5** Front Frame Assembly Removal



## Replacement

1. Place the front frame assembly in front of the deck.
2. Connect the ribbon cable (3) to the A2 front panel interface board.
3. Feed the coaxial cable BNC connector through the **External Trigger Input** hole in the front frame, matching the “D” slot. Secure with the nut removed earlier, using a 9/16” socket. Torque to 21 inch pounds.
4. Clip the coaxial cable into the two cable clamps positioned on the front frame shield.
5. Position the front frame on the deck using the alignment bosses on the deck (5). Remember to tuck the ribbon cable under the fans when pushing the frame onto the deck. This will insure proper airflow to cool the instrument. Using the T-10 driver, replace the 7 screws (1) that secure the front frame to the deck. Torque to 9 inch pounds.
6. Replace the instrument outer case. Refer to the “[Instrument Outer Case](#)” replacement procedure.

## RF Section E4440A, E4443A, E4445A

All of the individual components of the RF section can be removed with the RF section in place in the instrument. If necessary for some service situations, the RF section can be removed as a unit to make it easier to replace an individual device.

In either case, you must first remove the instrument outer case and top brace to gain access to the RF section. Refer to the “[Instrument Outer Case](#)” and the “[Top Brace](#)” removal procedures.

---

**CAUTION**

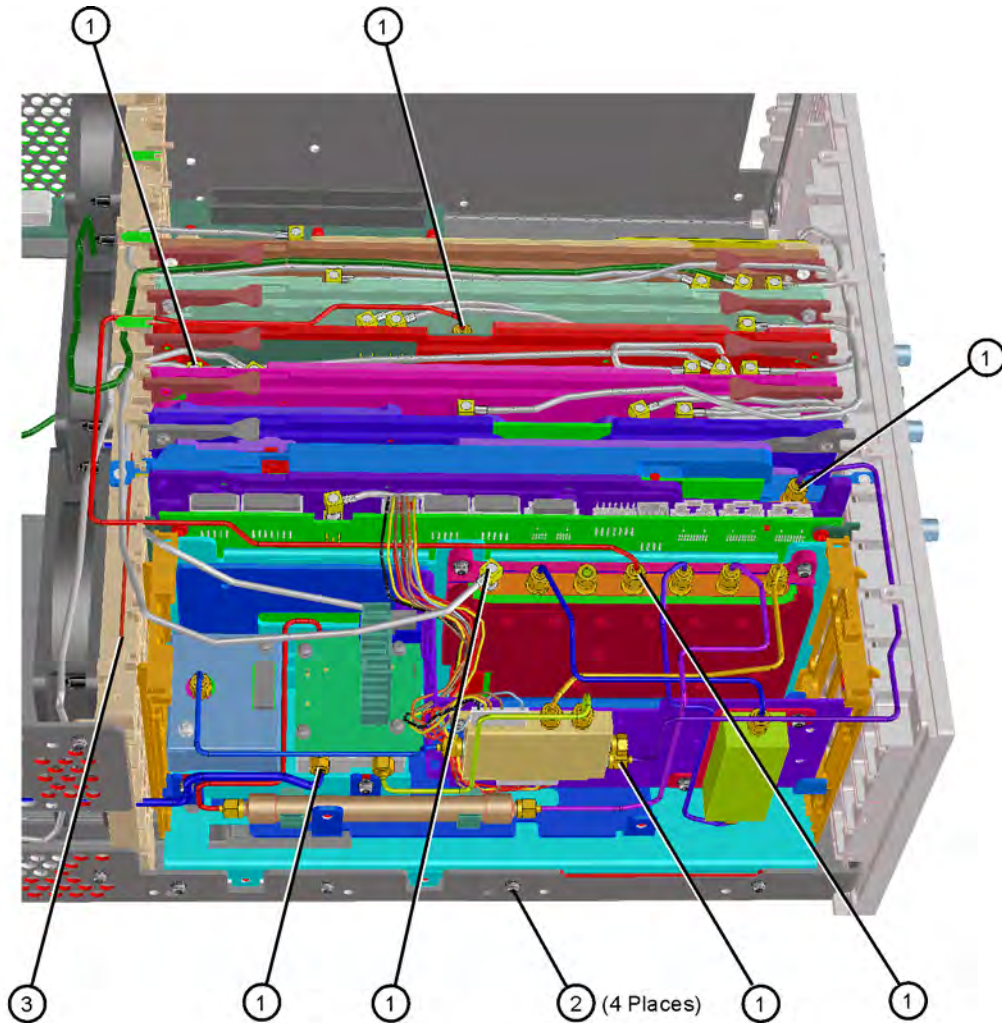
Use ESD precautions when performing this replacement procedure.

### Complete RF Section

#### Removal

1. Refer to [Figure 11-35 on page 358](#). Loosen, but don't remove the semi-rigid W9 cable at the attenuator.
2. Refer to [Figure 11-6](#). Remove the cable hold-down (3) by removing the one screw.
3. Remove the cables from the locations indicated (1).
4. Remove the ribbon cables from the A13 Front End Driver assembly.
5. Using the T-10 driver, remove the 4 screws (2).
6. The RF section can now be removed from the deck by sliding it up. Take care to avoid catching any cables on the assembly as you remove it.

**Figure 11-6 RF Section Removal**

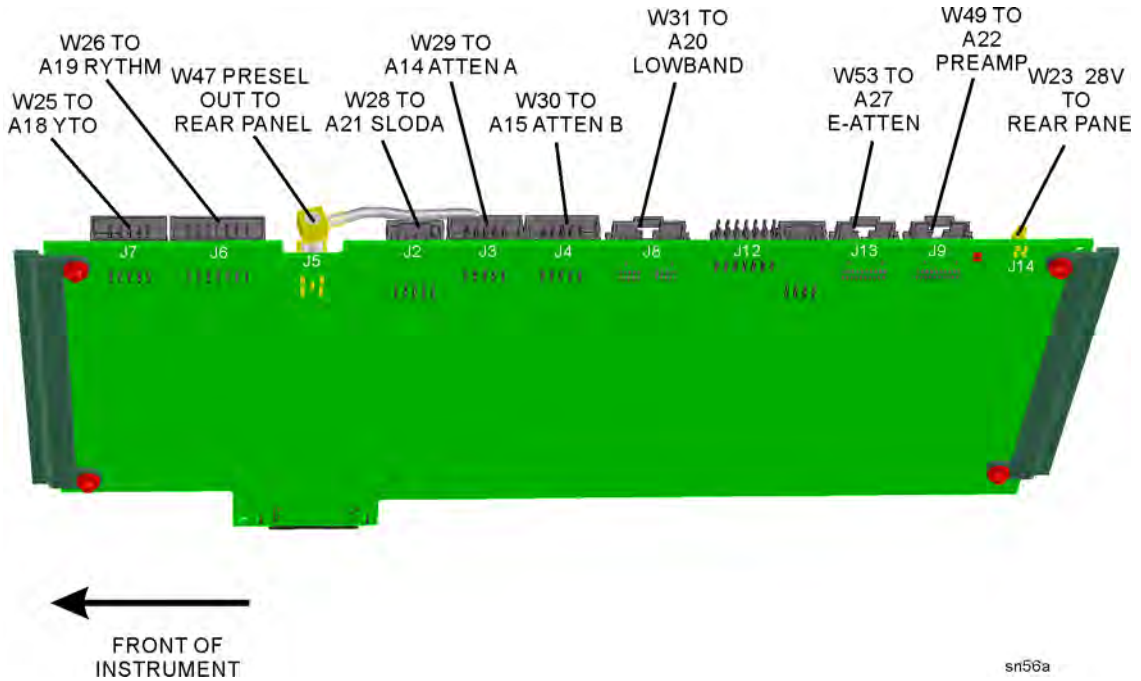


se856a

### Replacement

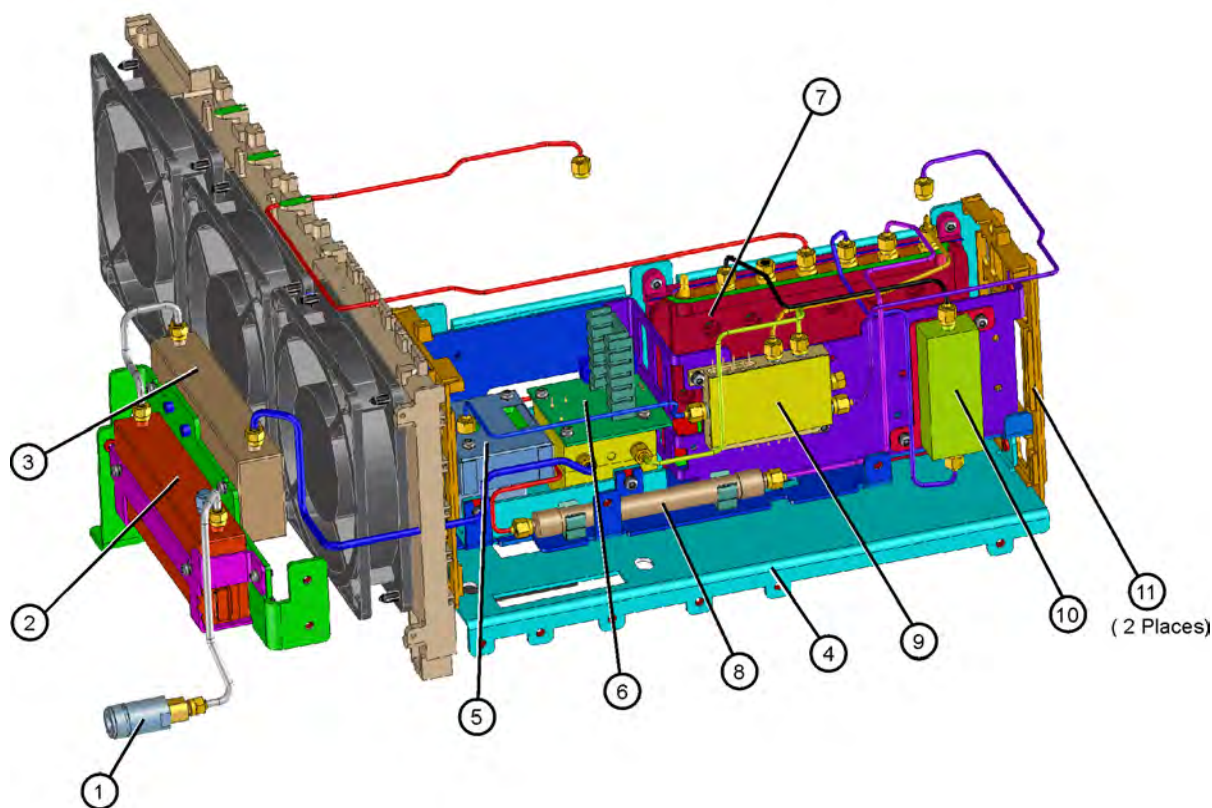
1. Position the RF section in the slots in the deck. Gently slide it down, making sure that no cables get caught.
2. Using the T-10 driver, replace the 4 screws. Torque to 9 inch pounds.
3. Replace the cables to the correct locations. Torque the semi-rigid cables to 10 inch pounds including the W9 cable at the input attenuator.
4. Replace the cable hold-down. Torque the single screw to 10 inch pounds.
5. Refer to [Figure 11-7](#). Replace the ribbon cables to the correct locations.

**Figure 11-7 RF Section Ribbon Cable Locations - E4440A, E4443A, E4445A**



## RF Assemblies E4440A, E4443A, E4445A

**Figure 11-8 RF Section Assemblies - Standard**

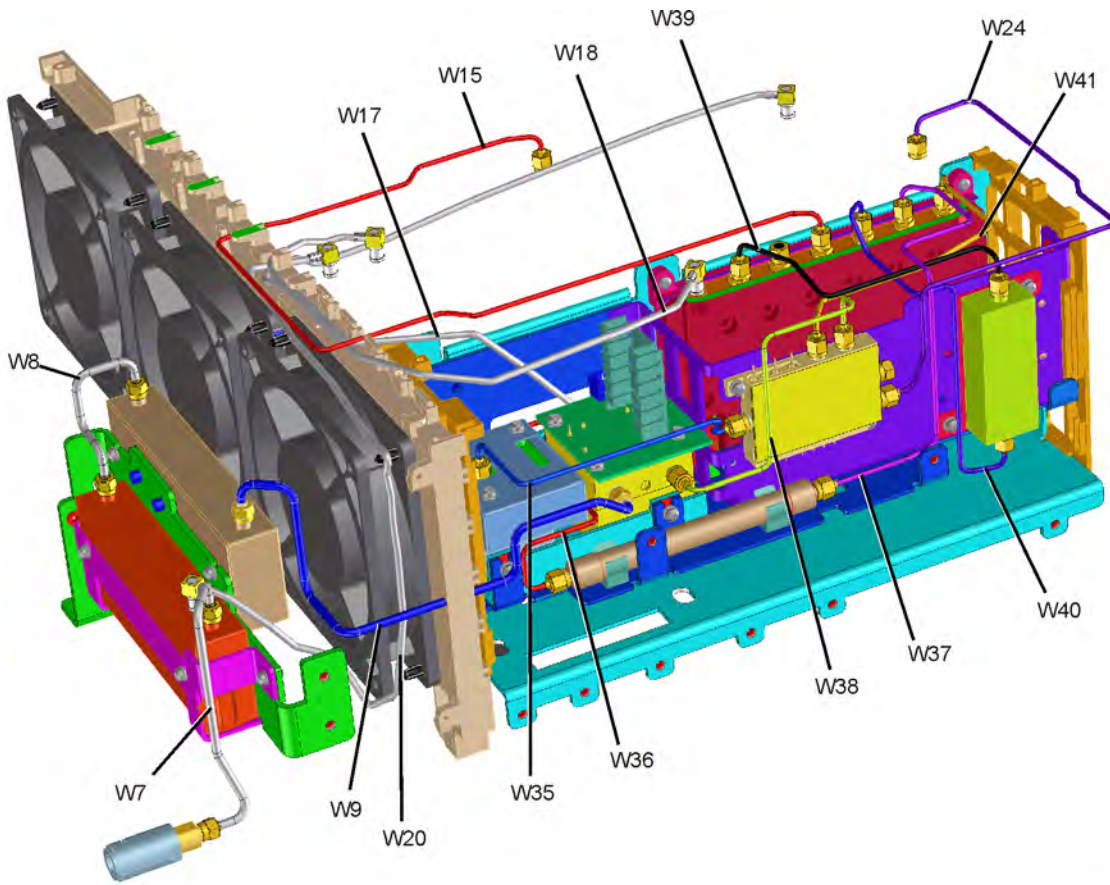


se819a

Item	Description	Item	Description
1	J1 Input Connector, Type N	7	A20 Low Band Assembly
2	A14 Attenuator/Switch	8	FL1 Low Pass Filter, 3 GHz
3	A15 Attenuator	9	A21 SLODA
4	L-bracket, RF Main	10	FL2 Band Pass Filter, 3.9214 GHz
5	A18 YTO	11	RF Frame
6	A19 RYTHM		

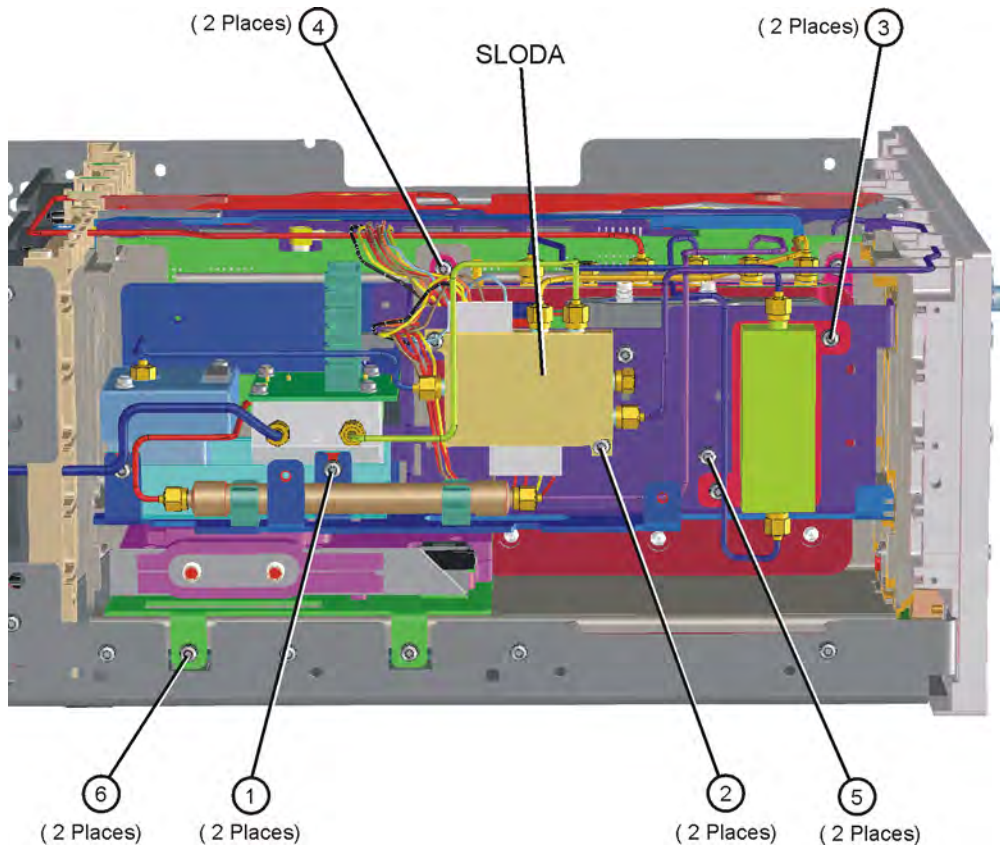


**Figure 11-9 RF Section Cables - Standard**



se830a

**Figure 11-10 RF Section Hardware**



## A18 YTO and A19 RYTHM

### Removal

1. Refer to [Figure 11-9](#). Remove the semi-rigid cables, W9, W35, W36, and W38.
2. Remove the ribbon cables attached to the YTO and RYTHM.
3. Refer to [Figure 11-10](#). Using the T-10 driver, remove the 2 screws (1). Remove the third screw that can be accessed down behind the YTO, near the Mid Web.
4. Carefully remove the bracket containing the YTO and RYTHM from the RF section.

5. To remove the YTO, remove the two bottom screws that attach it to the bracket. To remove the RYTHM, remove the four screws.

---

**CAUTION**

---

When you remove the two screws that attach the YTO to the bracket, the YTO will become detached from the YTO can. Take care to hold the complete YTO assembly while removing these screws.

### **Replacement**

1. Carefully place the YTO or RYTHM into the bracket.
2. Using the T-10 driver, replace the screws to attach the device to the bracket. Torque to 9 inch pounds.
3. Place the bracket into the RF section. Replace the three screws to attach the bracket to the RF section. Torque to 9 inch pounds.
4. Replace the cables to the correct locations. Torque the semi-rigid cables to 10 inch pounds.
5. Replace the ribbon cables to the YTO and RYTHM.

## **A21 SLODA**

### **Removal**

1. Refer to [Figure 11-9](#). Remove the semi-rigid cables W24, W35, W38, and W41.
2. Refer to [Figure 11-10](#). Remove the two wire harnesses from the SLODA.
3. Using the T-10 driver, remove the 2 screws (2).
4. The SLODA can now be removed from the RF section.

### **Replacement**

1. Place the SLODA in place on the bracket in the RF section.
2. Using the T-10 driver, replace the 2 screws. Torque to 9 inch pounds.
3. Reattach the wire harnesses to the SLODA.
4. Replace the cables to the correct locations. Torque the semi-rigid cables to 10 inch pounds.

## **FL1 Low Pass Filter**

### **Removal**

1. Refer to [Figure 11-8](#). Hold the FL1 lowpass filter (8) with a 7/16" open-end wrench while loosening semi-rigid cables W36 and W37.

2. Once the semi-rigid cables are loosened, FL1 can be removed from the RF section by pulling it from the clamps.

### **Replacement**

1. Snap FL1 into the clamps on the RF section.
2. Attach the semi-rigid cables to FL1. Hold FL1 with a 7/16" open-end wrench while tightening the semi-rigid cables to 10 inch pounds.

## **FL2 Band Pass Filter**

### **Removal**

1. Refer to [Figure 11-9](#). Remove the semi-rigid cables W39 and W40.
2. Refer to [Figure 11-10](#). Using the T-10 driver, remove the 2 screws (3). The FL2 band pass filter and bracket can now be removed from the RF section.

### **Replacement**

1. Place FL2 and bracket into position in the RF section.
2. Using the T-10 driver, replace the 2 screws that attach the filter to the bracket. Torque to 9 inch pounds.
3. Replace the semi-rigid cables to the correct locations. Torque to 10 inch pounds.

## **A20 Lowband**

### **Removal**

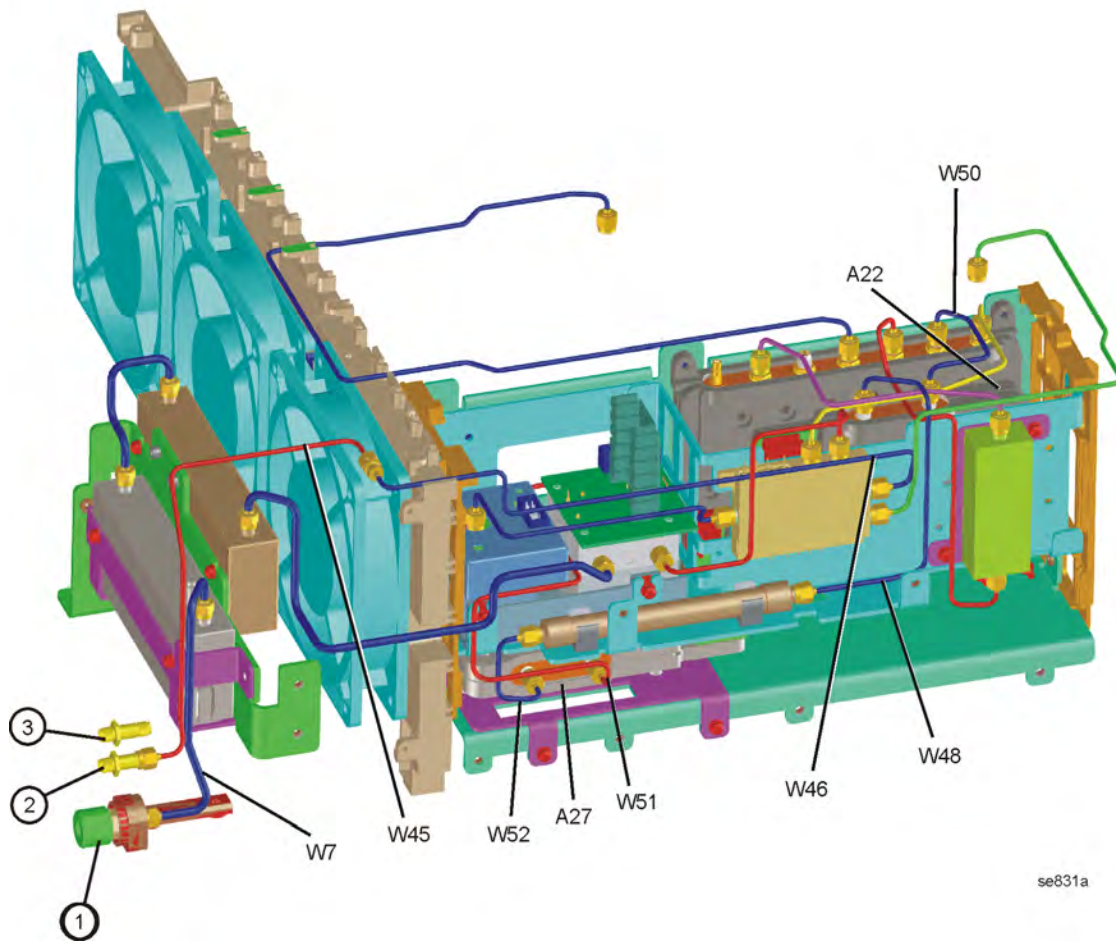
1. Refer to [Figure 11-9](#). Remove the semi-rigid cables W15, W18, W37, W39, W40, and W41.
2. Refer to [Figure 11-10](#). Using the T-10 driver, remove the 2 screws (4).
3. The Lowband assembly can now be removed from the RF section.

### **Replacement**

1. Place the Lowband assembly into position in the RF section.
2. Using the T-10 driver, replace the 2 screws that attach the assembly to the bracket. Torque to 9 inch pounds.
3. Replace the semi-rigid cables to the correct locations. Torque to 10 inch pounds.

## RF Section Option Assemblies E4440A, E4443A, E4445A

**Figure 11-11** Preamplifier and Electronic Attenuator Assemblies and Cable Locations



## A22 Preamplifier

### Removal

1. Refer to [Figure 11-11](#). Remove the semi-rigid cables W48 and W50.
2. Refer to [Figure 11-10](#). Using the T-10 driver, remove the 2 screws (5).
3. The preamplifier assembly can now be removed from the RF section.

### Replacement

1. Place the preamplifier assembly into position in the RF section.
2. Using the T-10 driver, replace the 2 screws that attach the assembly to the bracket. Torque to 9 inch pounds.
3. Replace the semi-rigid cables to the correct locations. Torque to 10 inch pounds.

## A27 Electronic Attenuator

### Removal

1. Refer to [Figure 11-11](#). Remove the semi-rigid cables W51 and W52.
2. Remove the ribbon cable from the attenuator assembly.
3. Refer to [Figure 11-10](#). Using the T-10 driver, remove the 2 screws (6).
4. The attenuator assembly can now be removed from the RF section.
5. To remove the attenuator assembly from the bracket, remove the four screws on the back.

### Replacement

1. If the attenuator was removed from the bracket, replace the four screws on the back. Torque to 9 inch pounds.
2. Place the attenuator assembly into position in the RF section.
3. Using the T-10 driver, replace the 2 screws that attach the assembly to the RF section. Torque to 9 inch pounds.
4. Replace the ribbon cable.
5. Replace the semi-rigid cables to the correct locations. Torque to 10 inch pounds.

### Option 110 Assemblies (E4440A, E4443A, E4445A)

Figure 11-12 Option 110 Assemblies and Cables

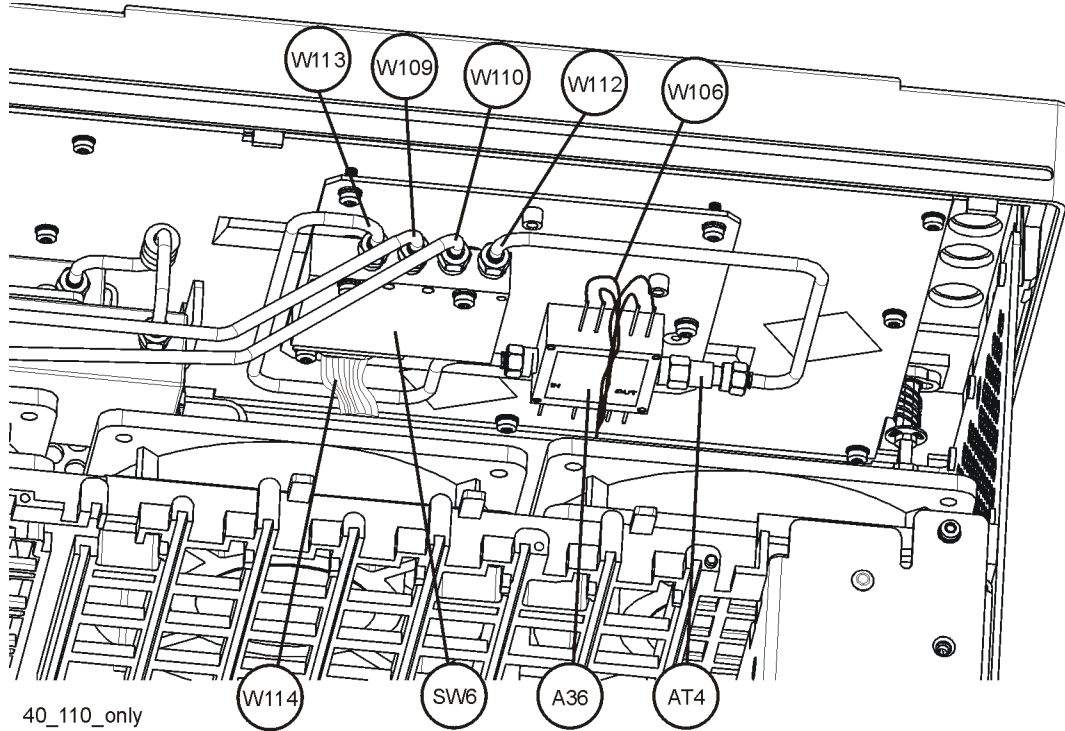
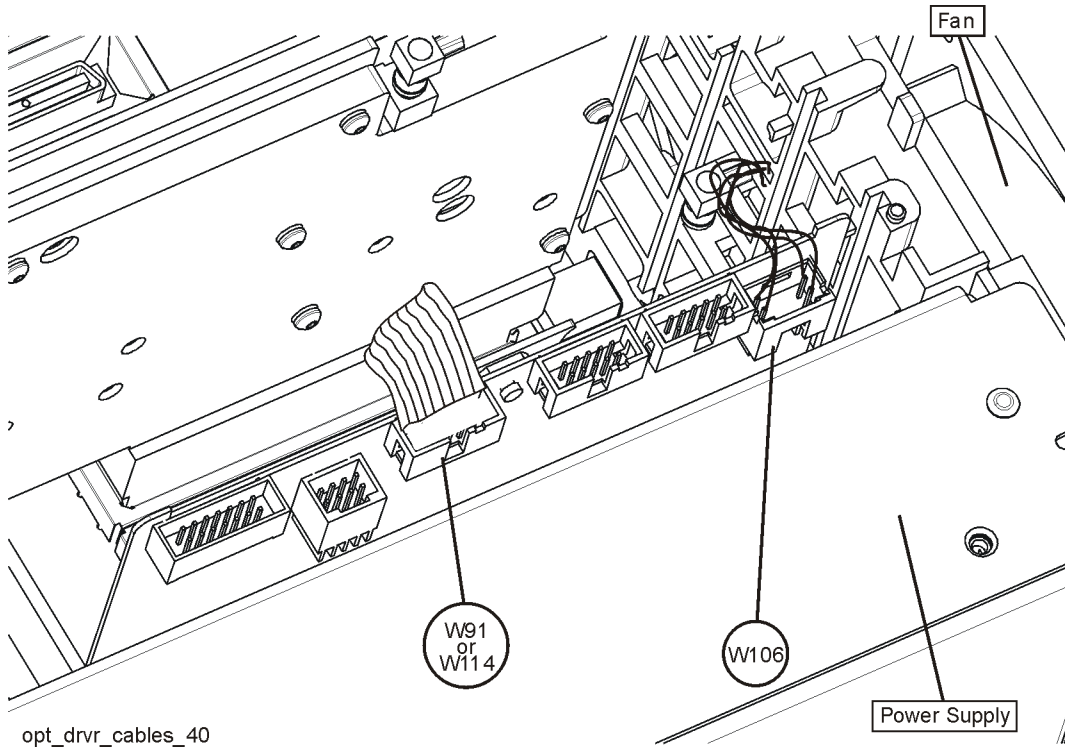


Figure 11-13 Option Driver Board Cables

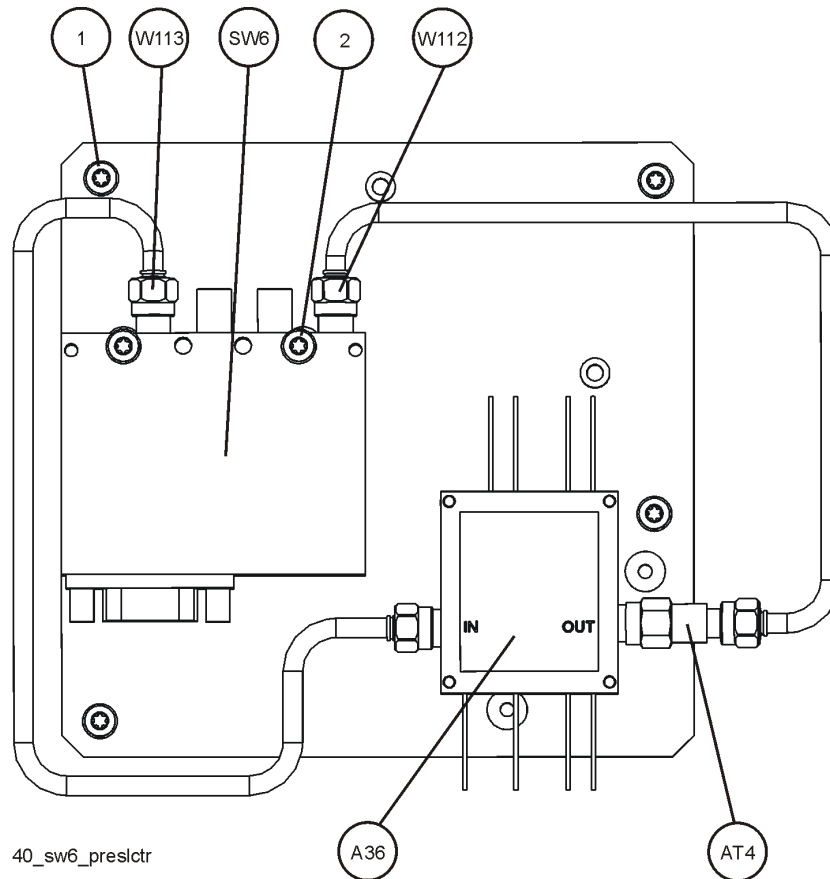


### A36 Preamplifier and SW6

To remove either the A36 Preamplifier or SW6 switch, it will be necessary to drop the front frame. To drop the front frame with Option 110 installed, follow these steps:

1. Refer to [Figure 11-12](#). Remove cables W109 and W110.
2. Refer to [Figure 11-13](#). Remove ribbon cable W114 and wire harness W106 from the Option driver board.
3. Drop the front frame. See [page 314](#) for instructions.

**Figure 11-14** Option 110 A36 Preamplifier and Switch SW6



### Option 110 SW6 Switch

#### Removal and Replacement

1. Refer to [Figure 11-14](#). To remove SW6, remove cables W112 and W113.
2. Remove the two screws (2).
3. To replace SW6, install it onto the bracket and secure it with the two screws (2) removed earlier. Torque to 9 inch-pounds.
4. Replace W112 and W113. Torque to 10 inch-pounds.

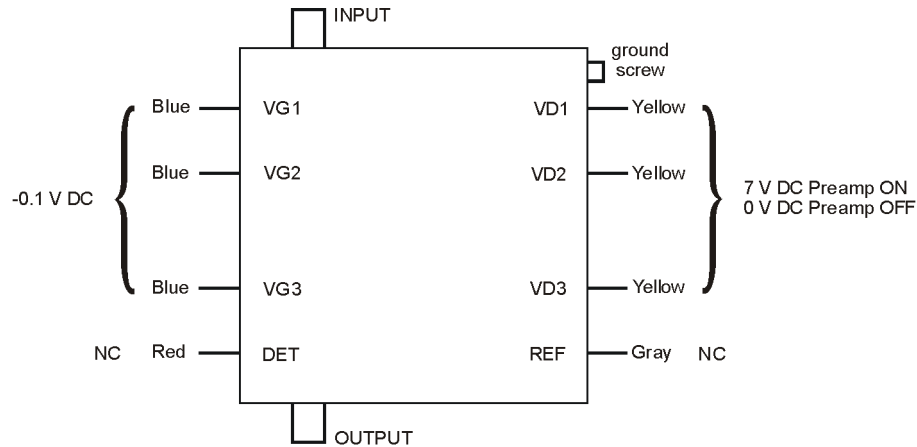


## Option 110 A36 Preamplifier

### Removal and Replacement

1. Refer to [Figure 11-14](#). To remove A36, remove cables W112 and W113.
2. Remove the bracket from the front panel by removing the four screws (1) and lifting the assembly from the front frame.
3. Remove all the wires from the preamplifier. The A36 Preamplifier can now be removed from the bracket by removing the four screws from the back of the bracket that attach the preamplifier.
4. To replace the preamplifier, install it on the bracket and attach it using the four screws removed earlier. Torque to 3 inch-pounds.
5. Refer to [Figure 11-15](#). Reattach the wires and ground wire to the preamplifier.

**Figure 11-15** Preamplifier Wires



opt110\_preamp

6. Replace W112 and W113. Torque to 10 inch-pounds.

## Option 123 Assemblies

Figure 11-16 Option 123 Assembly and Cable Locations

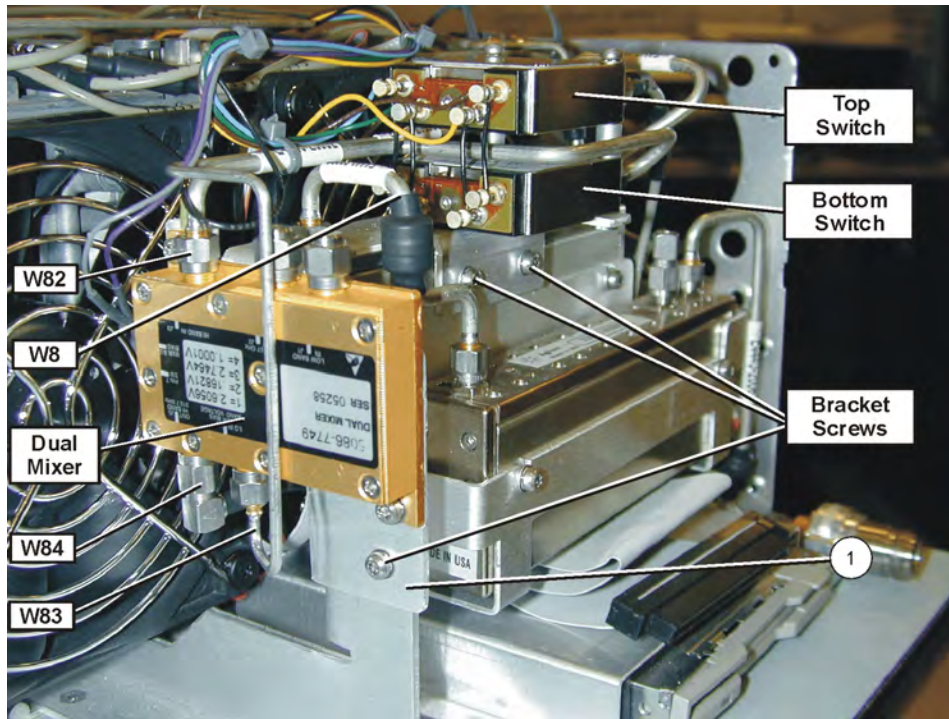
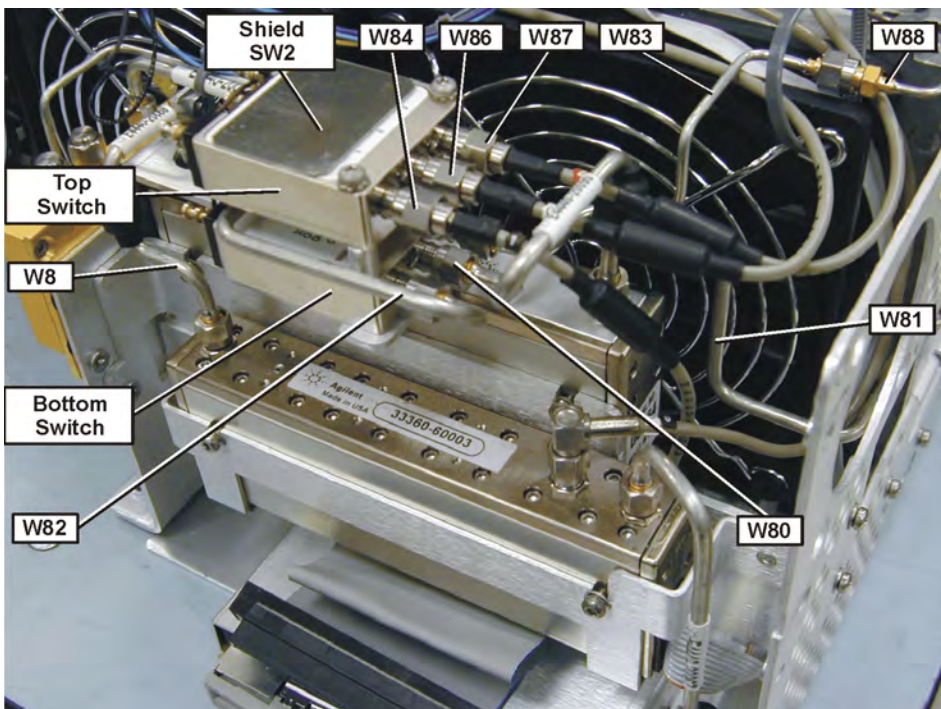


Figure 11-17 Option 123 Assembly and Cable Locations

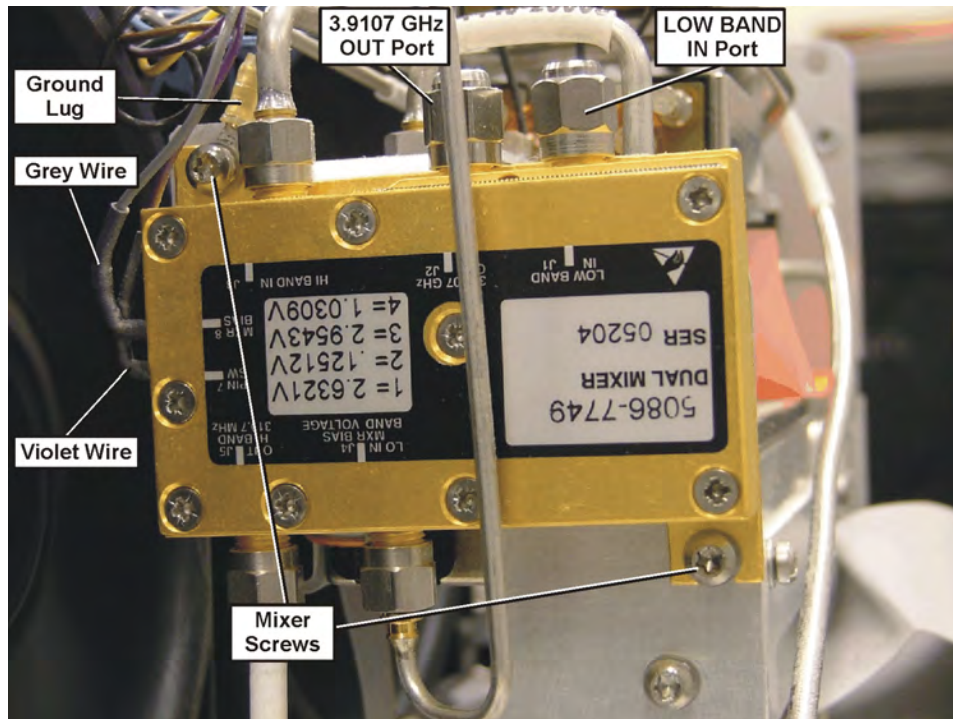


## Option 123 Dual Mixer

### Removal

1. Drop the front frame. See [page 314](#) for instructions.
2. Refer to [Figure 11-16](#). Remove cables W82, W83, and W84.
3. Refer to [Figure 11-18](#). Remove the grey and violet wires from the Dual Mixer connector pins.

**Figure 11-18 Dual Mixer**



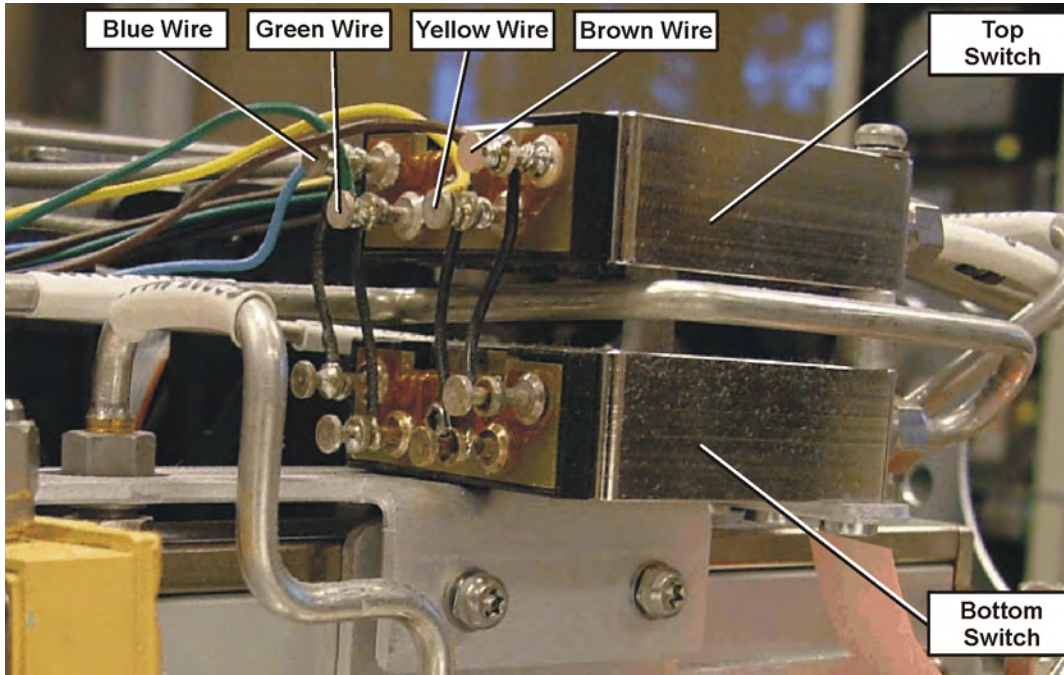
4. Remove the two mixer screws.
5. Remove the two SMA 50  $\Omega$  loads from the Low Band In port and the 3.9107 GHz OUT port. Install them on the replacement mixer.

### Replacement

1. Attach the Dual Mixer to the end of the switch bracket using two of the screws as shown in [Figure 11-18](#). Before inserting the top screw, locate the black wire with the ground lug that is part of the switch harness. Place the ground lug between the screw head and the mixer body. Torque the mounting screws to 9 in-lbs.
2. Connect the grey wire with the push on connector to the Dual Mixer bias pin. Connect the violet wire with the push on connector to the Pin 7 SW on the Dual Mixer.
3. Replace cables W82, W83, and W84. Torque to 10 in-lbs.
4. Replace the front frame.

## Option 123 Switches

**Figure 11-19** Option 123 Switch Wiring



### Top Switch Removal

1. Drop the front frame. See [page 314](#) for instructions.
2. Note the locations of the soldered wires on the switch terminals, particularly the black wires. [Figure 11-19](#) shows most wire locations.
3. Unsolder and remove the wires from all top switch solder-on terminals. When removing the black wires, avoid damaging the wires since there is little service length. The colored wires usually have extra length and you may wish to just cut them off and re-strip the ends.
4. Refer to [Figure 11-17](#). Remove cables W84, W86, and W87 from the top switch. Note that two of the cables have identification bands that correspond to the connector designator 1, or 2, printed on the switch.
5. Remove the two switch mounting screws and remove the switch. Be careful that the standoffs between the two switches are not lost.

## Top Switch Replacement

---

**NOTE**

---

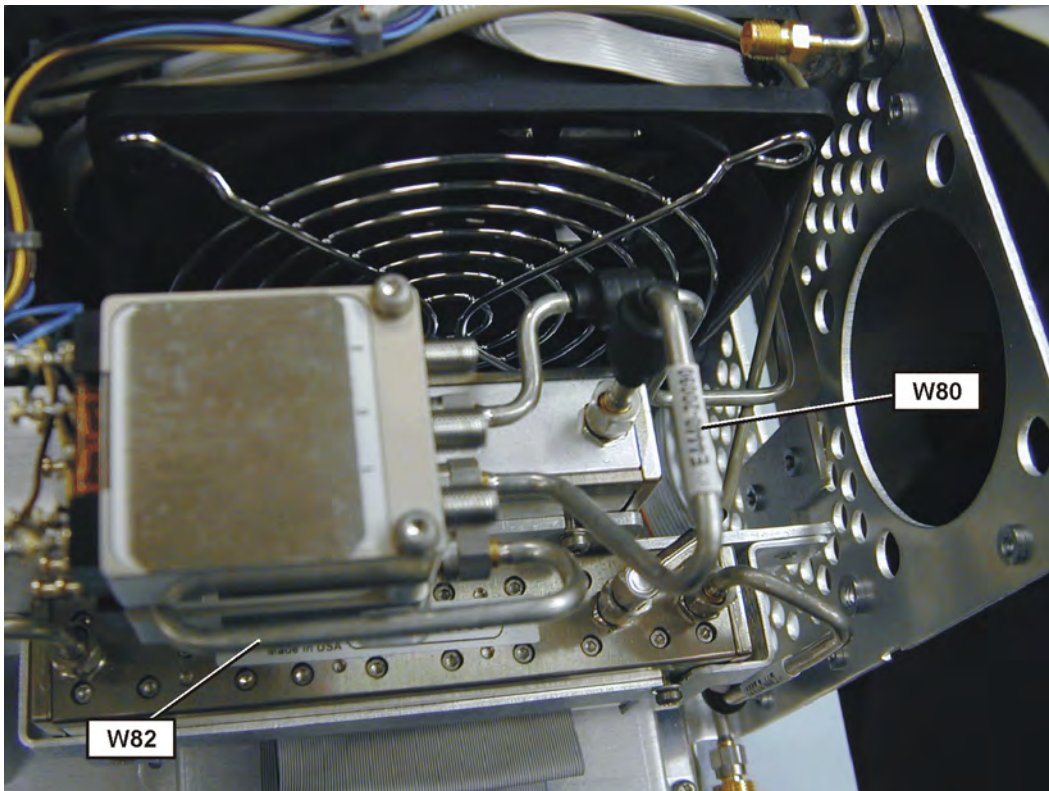
The replacement switch will not have the metal EMI shield installed. The shield is p/n E4440-00055. This shield is only used on the top switch.

1. Position the standoffs over the bottom switch mounting holes. Position the replacement top switch with the label up, and install the mounting screws.
2. Reconnect W84, W86 and W87 by matching the cable information bands to the switch connector designators. Torque to 10 in-lbs.
3. Refer to [Figure 11-19](#). Re-solder the wires removed earlier.
4. Attach the adhesive EMI shield to the top of the switch. [Figure 11-20](#) shows the proper position of the shield. Assure the switch port numbers are not covered.

### Bottom Switch Removal

1. Drop the front frame. See [page 314](#) for instructions.
2. Refer to [Figure 11-17](#). Remove cables W84, W86, and W87 from the top switch. Note that two of the cables have identification bands that correspond to the connector designator 1, or 2, printed on the switch.
3. Remove cable W81 at port 2 of the bottom switch.
4. Refer to [Figure 11-20](#). Remove W80 from the attenuator and from port C of the bottom switch and set the cable aside.

**Figure 11-20**      **Bottom Switch Cables**



5. Refer to [Figure 11-16](#) and [Figure 11-20](#). Remove cable W82 from the dual mixer and port 1 of the bottom switch. In order to completely remove the cable, you will need to position the flat sides of the SMA connector nut so it will fit between the two switches.
6. Loosen the switch mounting screw located closest to the fan. Loosen the screw just enough so the threads are clear of the mounting bracket but do not remove the screw.
7. Loosen the other switch mounting screw just enough to rotate both switches towards the front of the instrument. This allows room to unsolder the black jumper wires on the bottom switch.
8. Make note of the black jumper wire position on the bottom switch

then unsolder the jumper wires from the bottom switch. Avoid damage to the wires since they have little service length.

9. Remove the switch mounting screws being careful to keep track of the two standoffs between the switches.

### **Bottom Switch Replacement**

1. Position the replacement bottom switch on the switch bracket.
2. Pre-form the black jumper wires on the top switch for easier installation. Also inspect all solder connections.
3. Position the standoffs over the mounting holes and insert the mounting screws. Slightly tighten the screw close to the front of the instrument. Leave the screw close to the fan resting on the switch bracket, but with no threads engaged.
4. Rotate both switches toward the front of the instrument.
5. Solder the jumper wires.
6. Rotate the switches to their normal position and tighten the mounting screws.
7. Refer to [Figure 11-16](#). Install W82 from the dual mixer to the bottom switch port 2. Torque to 10 in-lbs
8. Refer to [Figure 11-17](#). Install W80 from the attenuator to the bottom switch port C.
9. Install W81. Torque to 10 in lbs.
10. Refer to [Figure 11-17](#). Install W84, W86 and W87 on the top switch. Note that two of the cables have identification bands that correspond to the connector designator 1, or 2, printed on the switch from the top switch.
11. Replace the front panel.

## RF Section E4446A, E4447A, E4448A

Most of the individual components of the RF section can be removed with the RF section in place in the instrument. If necessary for some service situations, the RF section can be removed as a unit to make it easier to replace an individual device.

In either case, you must first remove the instrument outer case and top brace to gain access to the RF section. Refer to the “[Instrument Outer Case](#)” and the “[Top Brace](#)” removal procedures.

---

**CAUTION**

Use ESD precautions when performing this replacement procedure.

### Complete RF Section

#### Removal

1. Refer to [Figure 11-35 on page 358](#). Loosen, but don't remove the semi-rigid W9 cable at the attenuator.
2. Refer to [Figure 11-21](#). Remove the cable hold-down (3) by removing the one screw.
3. Remove the cables from the locations indicated (1).

---

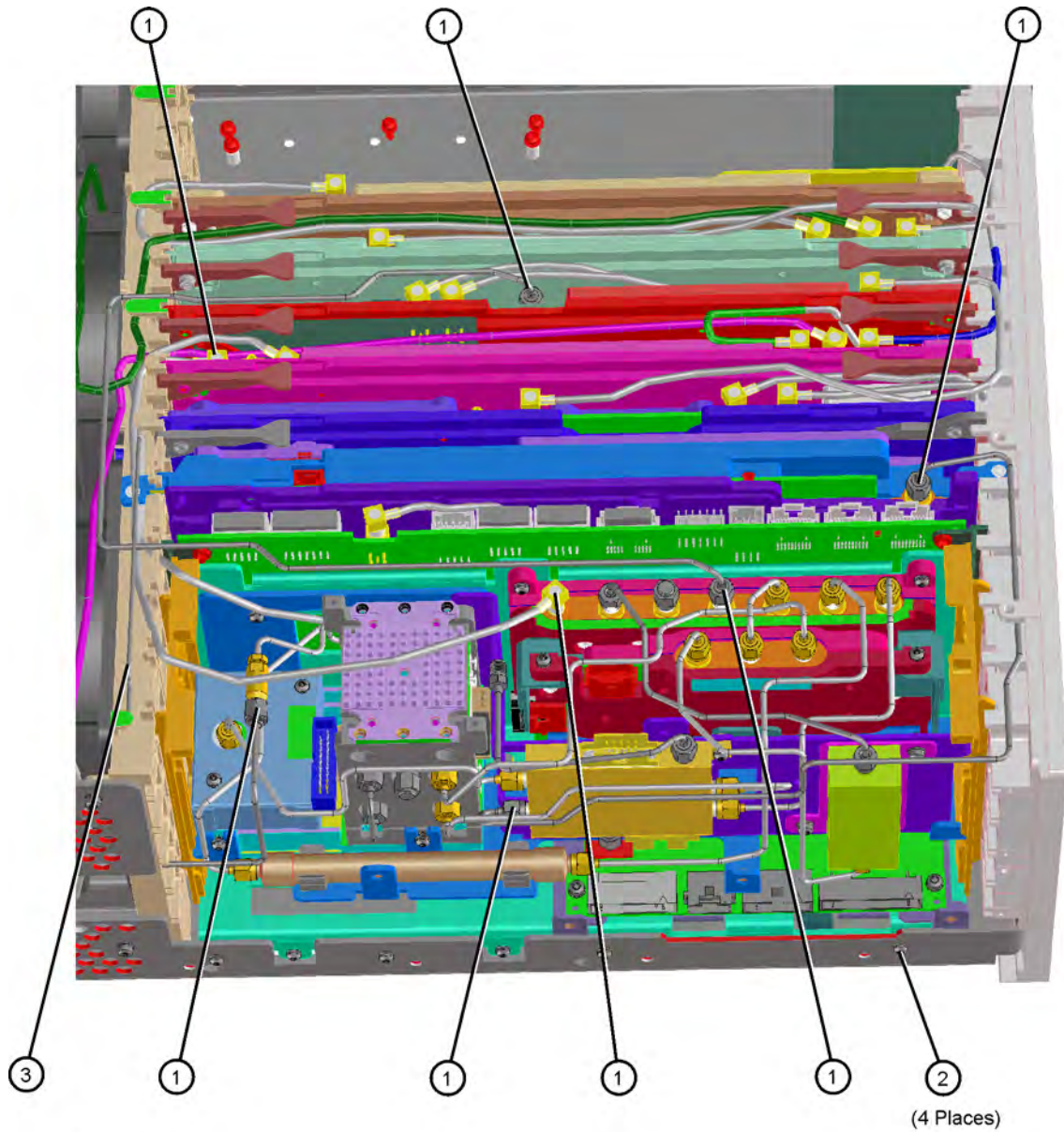
**NOTE**

For the E4447A, it is required that the A13 Front End Driver, A12 Synthesizer assembly, A11 Reference assembly, and the A10 Lowband/A30 FIFA assemblies be removed from the instrument. This allows the cable from the A10 3rd Converter to the A20 Lowband assembly to be disconnected. See the procedure for replacing the A20 Lowband assembly.

4. Remove the ribbon cables from the A13 Front End Driver assembly.
5. Using the T-10 driver, remove the 4 screws (2).
6. The RF section can now be removed from the deck by sliding it up. Take care to avoid catching any cables on the assembly as you remove it.



**Figure 11-21 RF Section Removal**

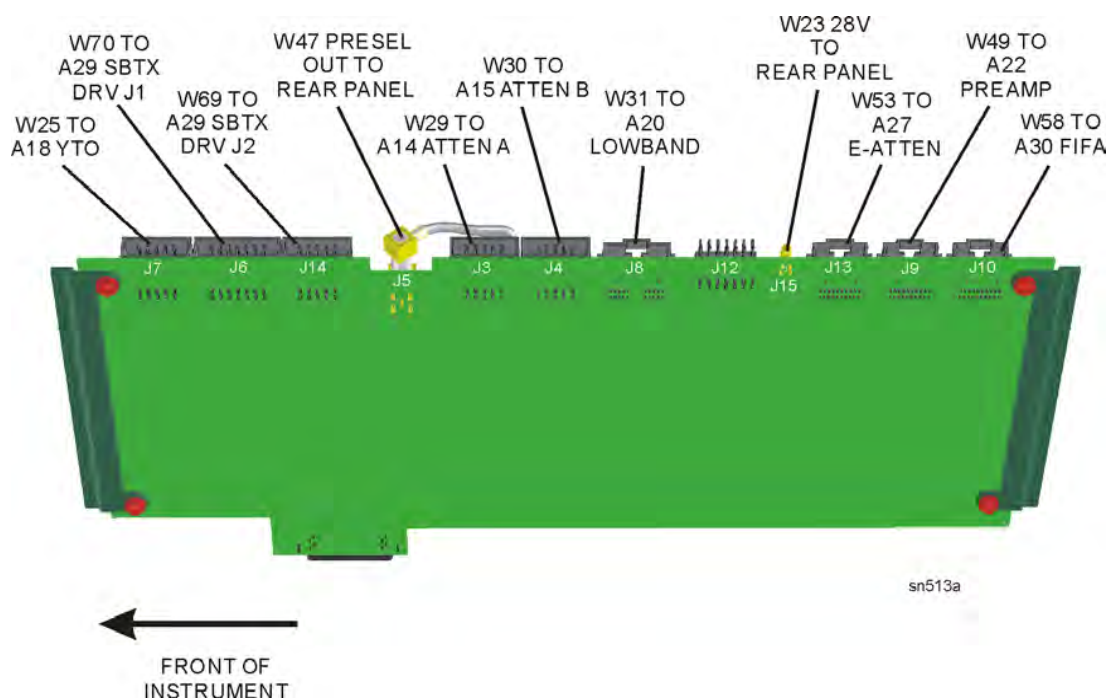


sn519a

## Replacement

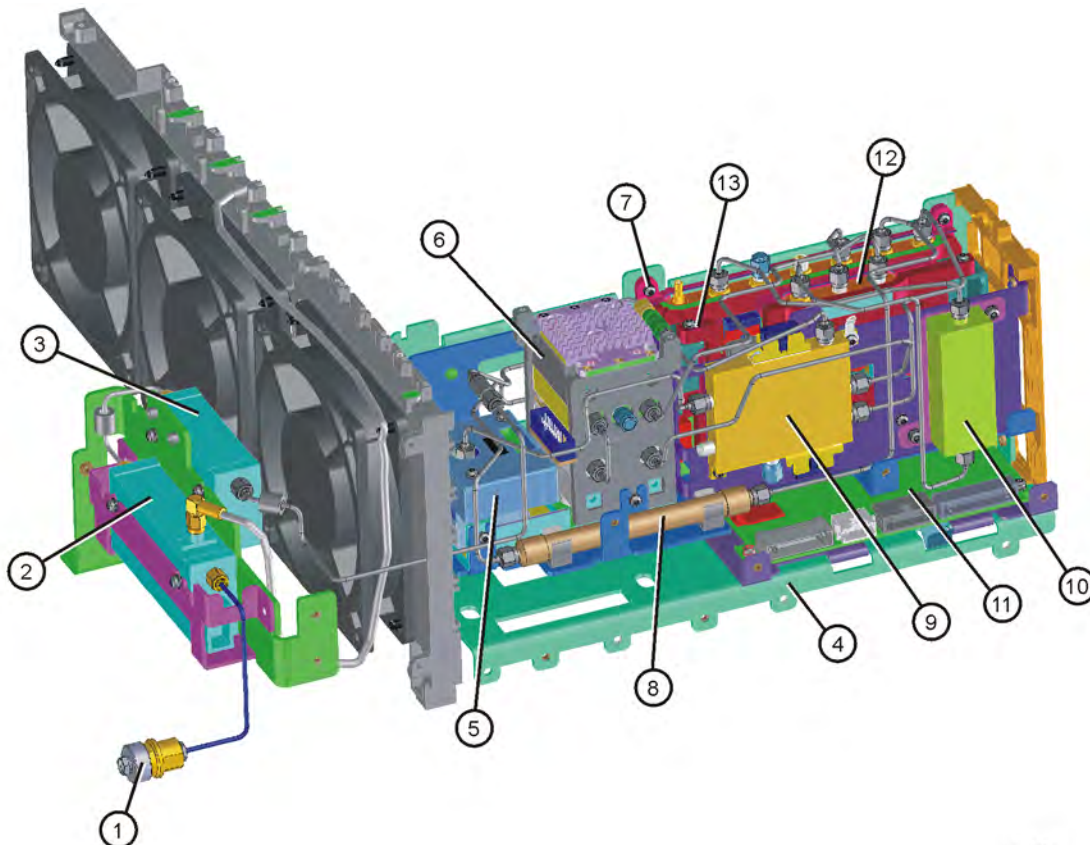
1. Position the RF section in the slots in the deck. Gently slide it down, making sure that no cables get caught.
2. Using the T-10 driver, replace the 4 screws. Torque to 9 inch pounds.
3. Replace the cables to the correct locations. Torque the semi-rigid cables to 10 inch pounds including the W9 cable at the input attenuator.
4. Replace the cable hold-down. Torque the single screw to 10 inch pounds.
5. Refer to [Figure 11-22](#). Replace the ribbon cables to the correct locations.

**Figure 11-22 RF Section Ribbon Cable Locations - E4446A, E4447A, E4448A**



## RF Assemblies E4446A, E4447A, E4448A

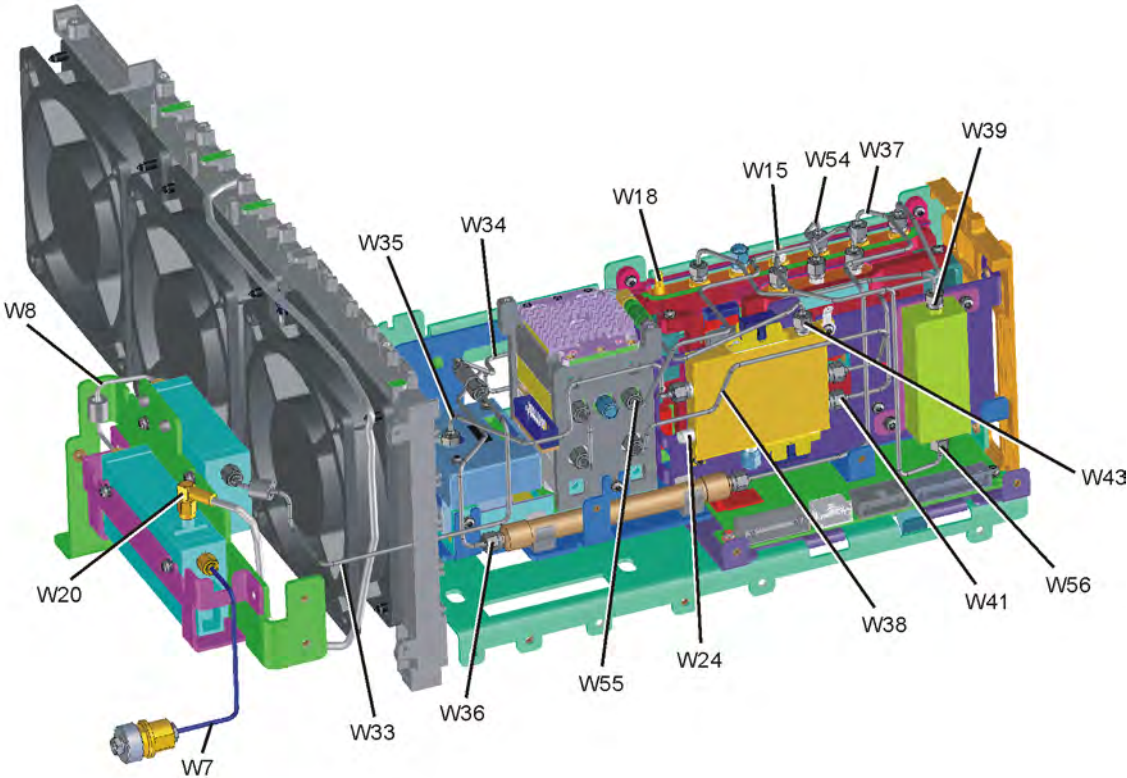
Figure 11-23 RF Section Assemblies - Standard



sn52a

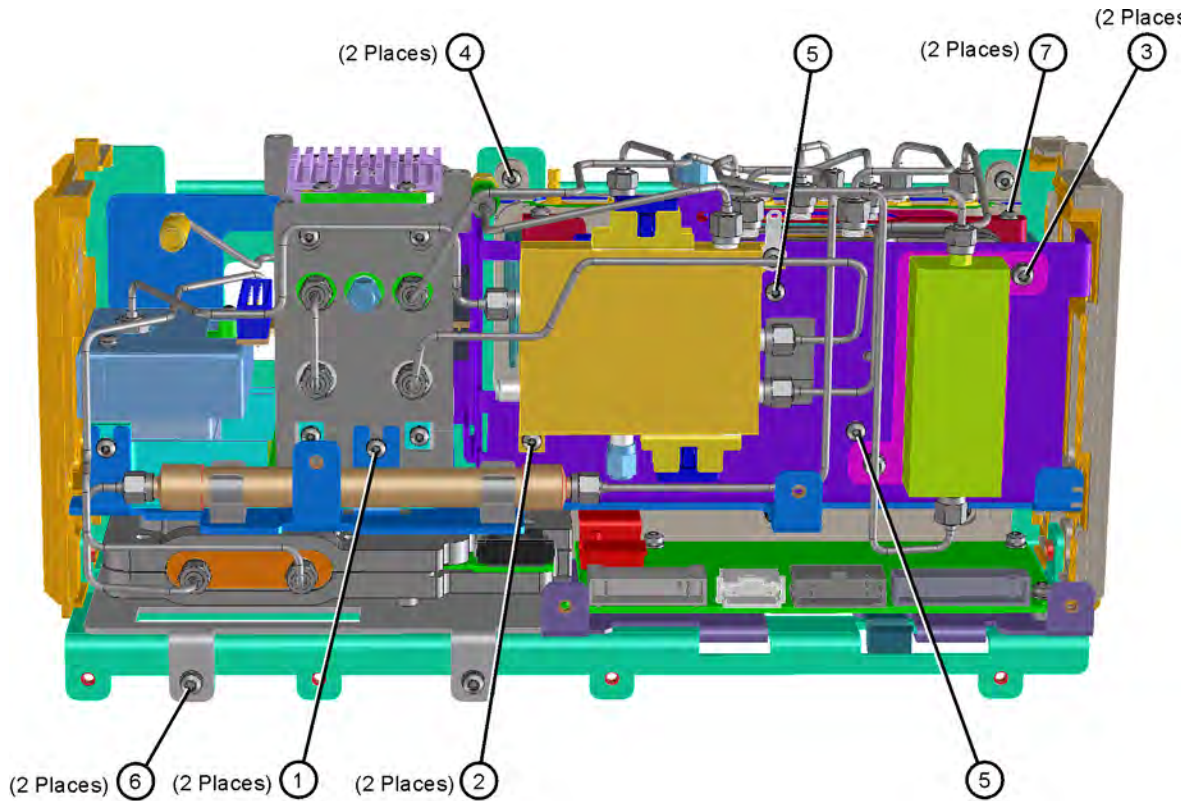
Item	Description	Item	Description
1	RF Input Connector	8	FL 1 Low Pass Filter, 3 GHz
2	A14 Attenuator/Switch	9	A21 FELOMA (Freq. Extended LO Multiplying Amp)
3	A15 Attenuator	10	FL 2 Band Pass Filter, 3.9124 GHz
4	L-bracket, RF Main	11	A29 SBTX Driver board
5	A18 YTO	12	A30 FIFA
6	A19 SBTX/RYTHM		
7	A20 Low Band Assembly		

Figure 11-24 RF Section Cables - Standard



sn517a

**Figure 11-25 RF Section Hardware**



sn55a

## A18 YTO and A19 SBTX/RYTHM

### Removal

1. Refer to [Figure 11-24](#). Remove the semi-rigid cables, W33, W35, W36, and W38.
2. Remove the ribbon cables attached to the YTO and SBTX/RYTHM.
3. Refer to [Figure 11-25](#). Using the T-10 driver, remove the 2 screws (1). Remove the third screw that can be accessed down behind the YTO, near the Mid Web.
4. Carefully remove the bracket containing the YTO and SBTX/RYTHM from the RF section.

5. To remove the YTO, remove the two bottom screws that attach it to the bracket. Do not remove the RYTHM from the bracket.

---

**CAUTION**

---

When you remove the two screws that attach the YTO to the bracket, the YTO will become detached from the YTO can. Take care to hold the complete YTO assembly while removing these screws.

### **Replacement**

1. Carefully place the YTO into the bracket.
2. Using the T-10 driver, replace the screws to attach the device to the bracket. Torque to 9 inch pounds.
3. Place the bracket into the RF section. Replace the three screws to attach the bracket to the RF section. Torque to 9 inch pounds.
4. Replace the cables to the correct locations. Torque the semi-rigid cables to 10 inch pounds.
5. Replace the ribbon cables to the YTO and SBTX/RYTHM.

## **A21 FELOMA**

### **Removal**

1. Refer to [Figure 11-24](#). Remove the semi-rigid cables W24, W35, W38, W41, and W43.
2. Refer to [Figure 11-23](#). Remove the two wire harnesses from the FELOMA (9).
3. Refer to [Figure 11-25](#). Using the T-10 driver, remove the 2 screws (2).
4. The FELOMA can now be removed from the RF section.

### **Replacement**

1. Place the FELOMA in place on the bracket in the RF section.
2. Using the T-10 driver, replace the 2 screws. Torque to 9 inch pounds.
3. Reattach the wire harnesses to the FELOMA.
4. Replace the cables to the correct locations. Torque the semi-rigid cables to 10 inch pounds.

## **FL1 Low Pass Filter**

### **Removal**

1. Refer to [Figure 11-23](#). Hold the FL1 lowpass filter (8) with a 7/16" open-end wrench while loosening semi-rigid cables W36 and W37.

2. Once the semi-rigid cables are loosened, FL1 can be removed from the RF section by pulling it from the clamps.

### **Replacement**

1. Snap FL1 into the clamps on the RF section.
2. Attach the semi-rigid cables to FL1. Hold FL1 with a 7/16" open-end wrench while tightening the semi-rigid cables to 10 inch pounds.

## **FL2 Band Pass Filter**

### **Removal**

1. Refer to [Figure 11-24](#). Remove the semi-rigid cables W39 and W56.
2. Refer to [Figure 11-25](#). Using the T-10 driver, remove the 2 screws (3). The FL2 band pass filter and bracket can now be removed from the RF section.

### **Replacement**

1. Place FL2 and bracket into position in the RF section.
2. Using the T-10 driver, replace the 2 screws that attach the filter to the bracket. Torque to 9 inch pounds.
3. Replace the semi-rigid cables to the correct locations. Torque to 10 inch pounds.

## **A20 Lowband (E4446A, E4448A)**

### **Removal**

1. Refer to [Figure 11-24](#). Remove the cables W15, W18, W37, W39, W41, W54, W55, and W56.
2. Refer to [Figure 11-25](#). Using the T-10 driver, remove the 2 screws (4).
3. The Lowband and FIFA assemblies can now be removed from the RF section as a unit. To separate the two assemblies, remove the 2 screws (7) that attach the FIFA to the bracket.

### **Replacement**

1. Place the Lowband and FIFA assemblies into position in the RF section.
2. Using the T-10 driver, replace the 2 screws that attach the assembly to the bracket. Torque to 9 inch pounds.
3. Replace the cables to the correct locations. Torque the semi-rigid cables to 10 inch pounds.

## A20 Lowband (E4447A only)

### Removal

1. Remove the A13 Front End Driver, A12 Synthesizer, and A11 Reference assemblies. The cable hold down wire will need to be removed in order to remove the Synthesizer assembly.
2. Refer to [Figure 11-24](#). Remove the semi-rigid cables W15, W37, W39, W41, W54, W55, and W56. Cable W18 will be removed when the A20 Lowband and A30 FIFA are separated.
3. Refer to [Figure 11-25](#). Using the T-10 driver, remove the 2 screws (4) that attach the Lowband assembly to the instrument. the Lowband and FIFA assemblies can now be removed from the RF section as a unit.
4. Separate the FIFA from the Lowband assembly by removing the 2 screws (7).
5. Remove the bracket from the Lowband assembly. This allows cable W18 to be removed from the Lowband assembly.

### Replacement

1. Assure the flexible coax cable W18 from the 3rd Converter is routed through the hole in the RF deck shield. Connect the cable to the Lowband assembly.
2. Replace the bracket on the Lowband assembly, and attach the FIFA to the bracket. Torque the screws to 9 inch pounds.
3. Place the Lowband and FIFA assemblies into position in the RF section and attach with the two screws removed in [step 3](#) above.
4. Replace all semi-rigid cables removed from the RF section. Torque to 10 inch pounds.
5. Assure the flexible coax cable from the Lowband to the 3rd Converter is routed along the motherboard so it will not get damaged when the 3 assemblies removed earlier are replaced. Also, assure there is no slack in the cable from the Lowband connector to where the cable goes through the RF section shield.
6. Replace the 3 board assemblies, attach all cables, and the cable hold down wire.



## A29 SBTX Driver Board

### Removal

1. Remove the ribbon cables attached to the SBTX driver board.
2. The SBTX Driver board can now be removed from the RF section by sliding it out while pulling up on the spring tab.

### Replacement

1. Place the SBTX Driver board into position in the RF section and slide it into place until the spring tab clicks into position.
2. Replace the ribbon cables to the correct locations.

## A30 FIFA

### Removal

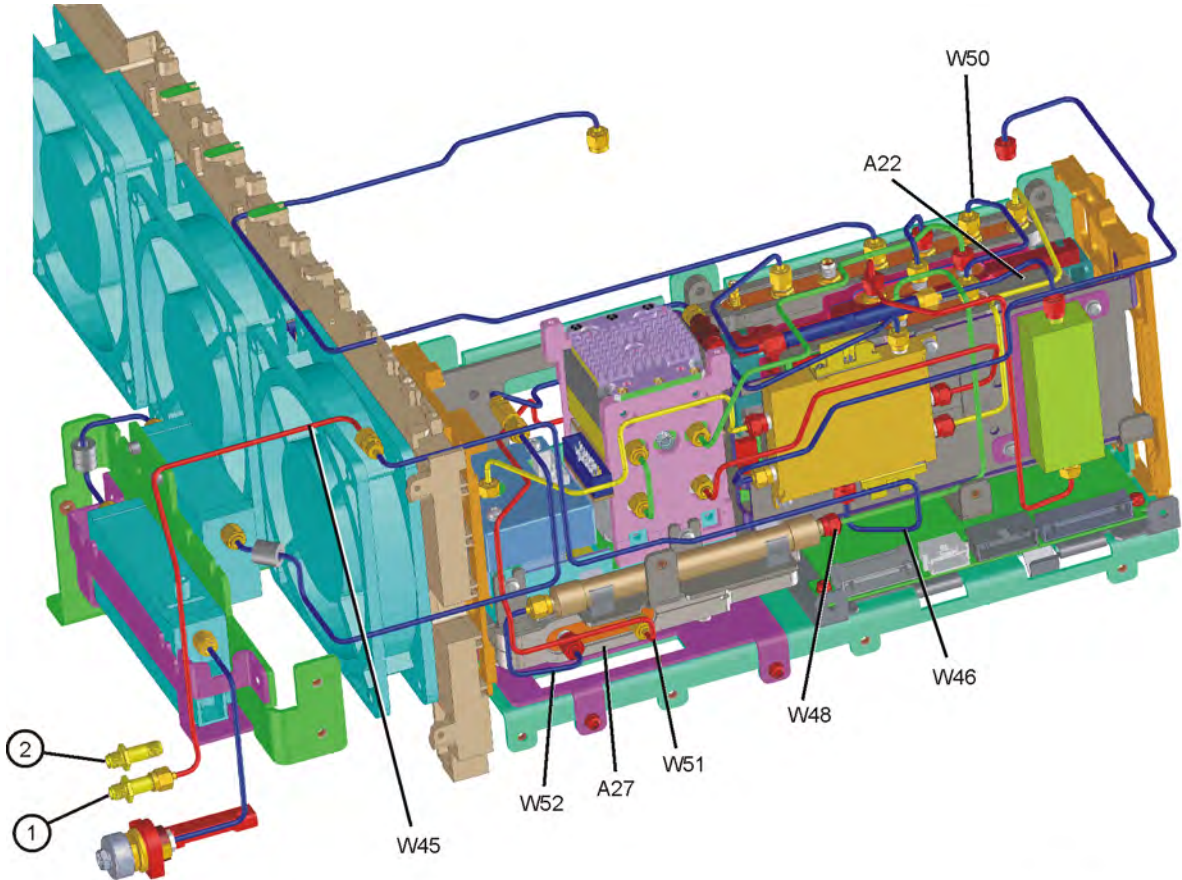
1. Refer to [Figure 11-24](#). Remove the semi-rigid cables W37, W39, W41, W54, W55, and W56.
2. Refer to [Figure 11-25](#). Using the T-10 driver, remove the 2 screws (7).
3. The FIFA assembly can now be removed from the RF section.

### Replacement

1. Place the FIFA assembly into position in the RF section.
2. Using the T-10 driver, replace the 2 screws that attach the assembly to the bracket. Torque to 9 inch pounds.
3. Replace the semi-rigid cables to the correct locations. Torque to 10 inch pounds.

### RF Section Option Assemblies E4446A, E4447A, E4448A

Figure 11-26



sn53a

## A22 Preamplifier

### Removal

1. Refer to [Figure 11-26](#). Remove the semi-rigid cables W48 and W50.
2. Refer to [Figure 11-25](#). Using the T-10 driver, remove the 2 screws (5).
3. The preamplifier assembly can now be removed from the RF section.

### Replacement

1. Place the preamplifier assembly into position in the RF section.
2. Using the T-10 driver, replace the 2 screws that attach the assembly to the bracket. Torque to 9 inch pounds.
3. Replace the semi-rigid cables to the correct locations. Torque to 10 inch pounds.

## A27 Electronic Attenuator

### Removal

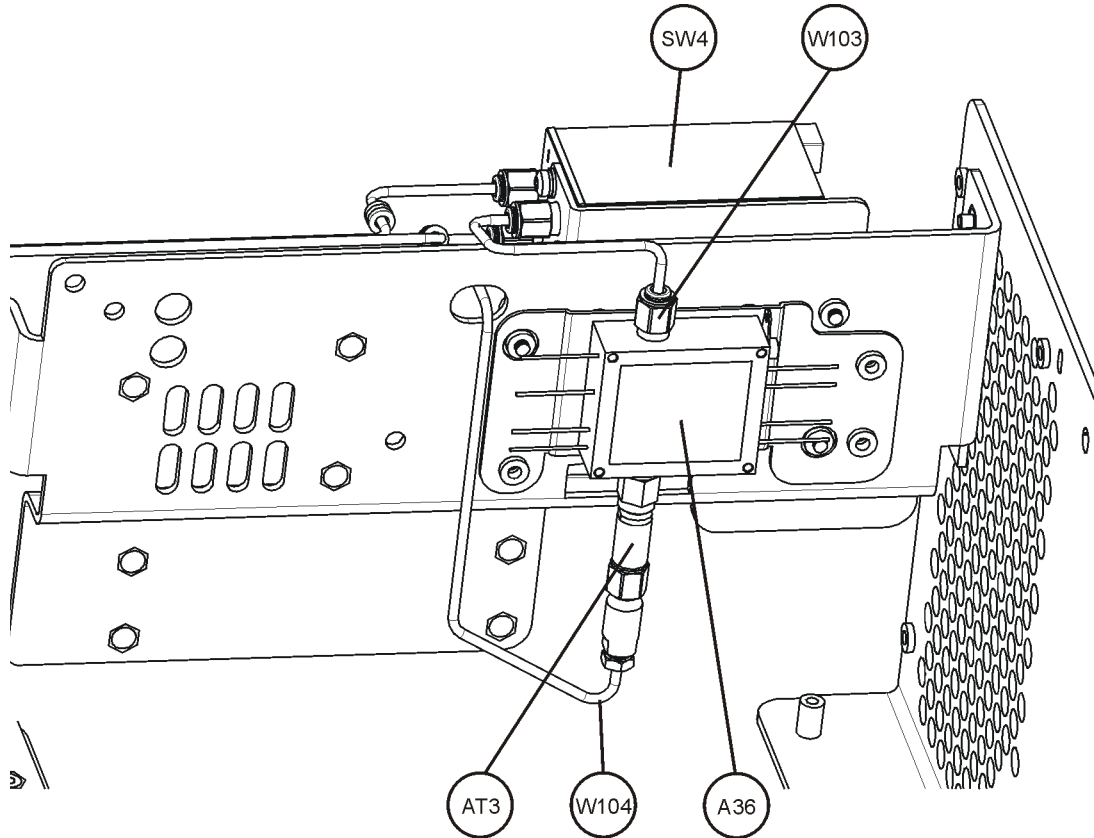
1. Refer to [Figure 11-26](#). Remove the semi-rigid cables W51 and W52.
2. Remove the ribbon cable from the attenuator assembly.
3. Refer to [Figure 11-25](#). Using the T-10 driver, remove the 2 screws (6).
4. The attenuator assembly can now be removed from the RF section.
5. To remove the attenuator assembly from the bracket, remove the four screws on the back.

### Replacement

1. If the attenuator was removed from the bracket, replace the four screws on the back. Torque to 9 inch pounds.
2. Place the attenuator assembly into position in the RF section.
3. Using the T-10 driver, replace the 2 screws that attach the assembly to the RF section. Torque to 9 inch pounds.
4. Replace the ribbon cable.
5. Replace the semi-rigid cables to the correct locations. Torque to 10 inch pounds.

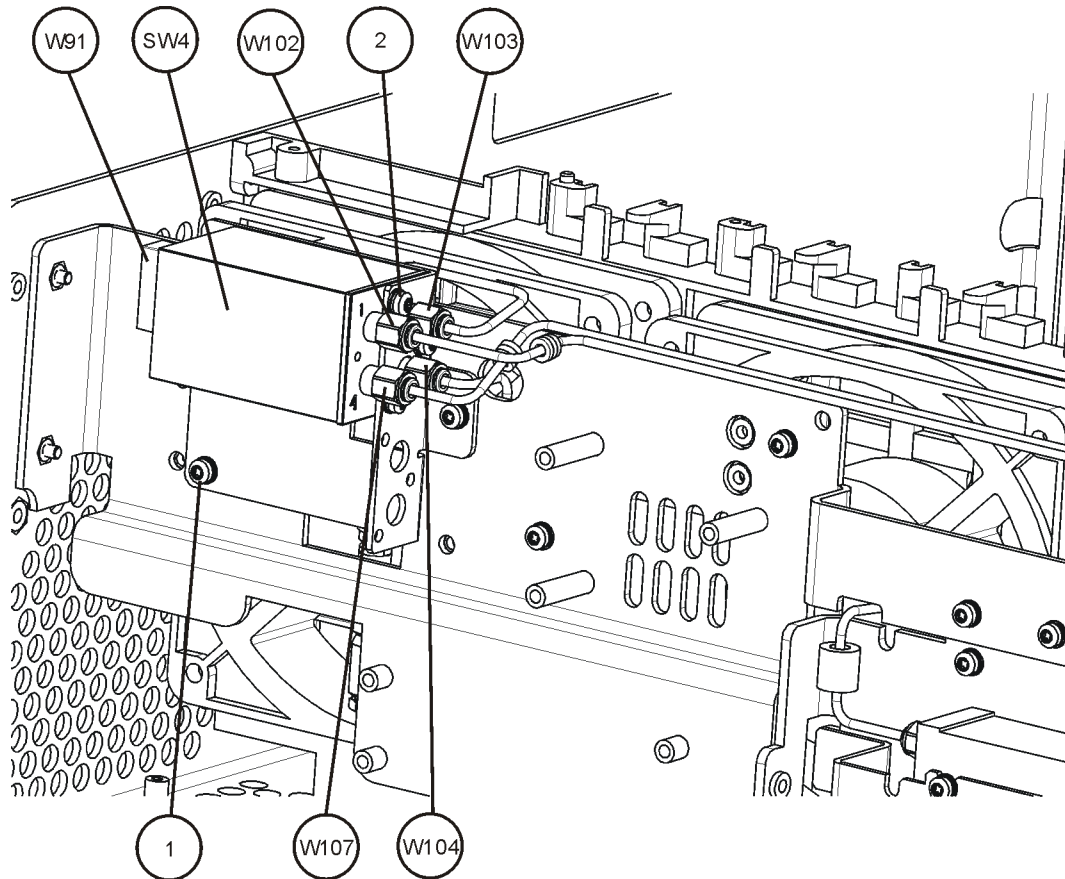
### Option 110 Assemblies E4446A, E4447A, E4448A

**Figure 11-27** Option 110 Assembly and Cable Locations



\_110\_only\_rear

**Figure 11-28 Option 110 Front View**



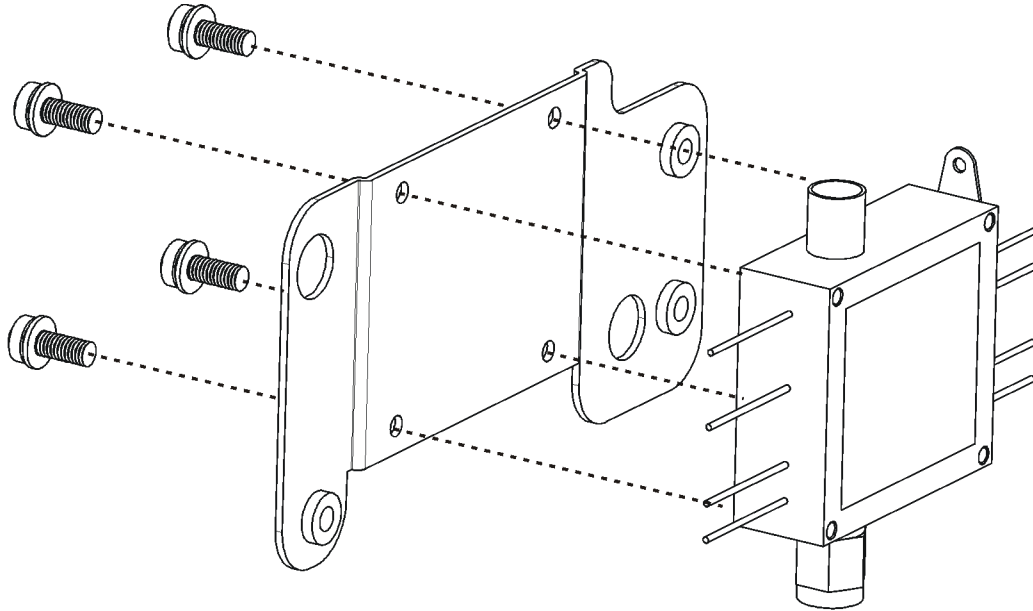
46\_110\_only

### **Option 110 A36 Preamplifier**

#### **Removal**

1. Drop the front frame. See [page 314](#) for instructions.
2. Refer to [Figure 11-27](#). Remove cables W103, and W104 with AT3. Remove all the wires from the A36 Preamplifier.
3. Refer to [Figure 11-28](#). Remove the three screws (1) and lift the preamplifier and bracket from the instrument.
4. Remove the wire from the ground lug of the preamplifier.
5. Refer to [Figure 11-29](#). To separate the preamplifier from the bracket, remove the four screws from the back of the bracket.

**Figure 11-29 Preamplifier and Bracket**

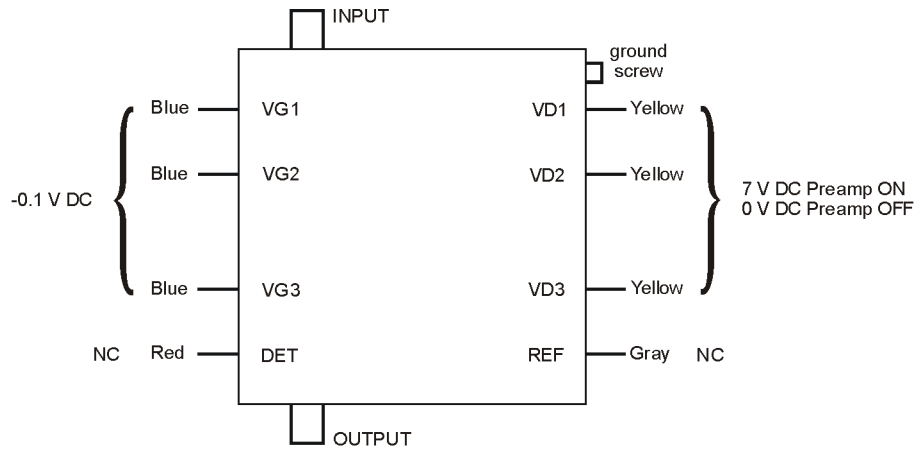


110\_preslctr\_bracket

### **Replacement**

1. Attach the preamplifier to the bracket using the four screws removed earlier. Torque to 3 inch-pounds.
2. Attach the ground wire to the ground lug of the preamplifier.
3. Install the preamplifier/bracket assembly into position and attach with the three screws (1). Refer to [Figure 11-28](#). Torque to 9 inch-pounds.
4. Refer to [Figure 11-27](#). Replace cables W103, and W104 with AT3. Torque to 9 inch-pounds.
5. Refer to [Figure 11-30](#). Replace the wires onto the preamplifier in the positions shown.

**Figure 11-30 Preamplifier Wires**



opt110\_preamp

6. Replace the front frame.

### SW4 Millimeter Switch

#### Removal

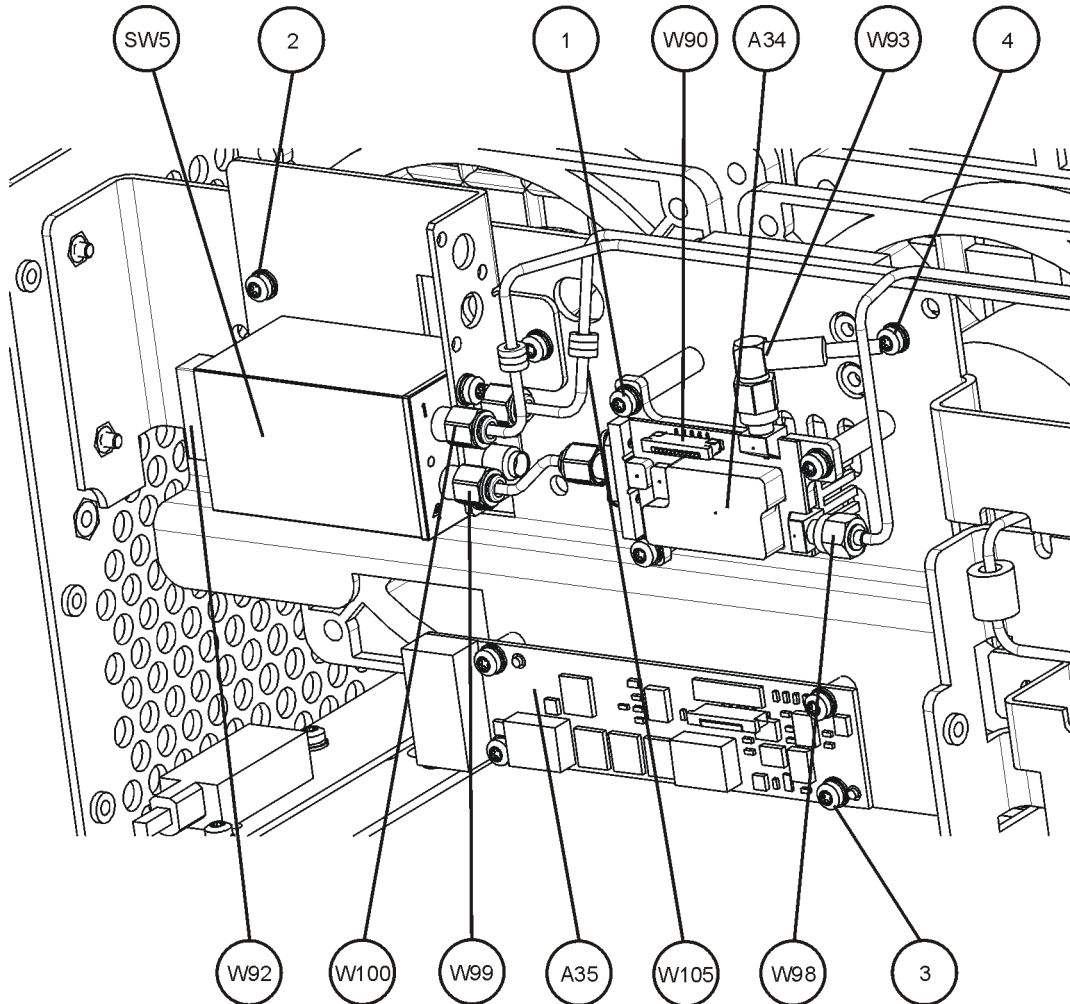
1. Drop the front frame. See [page 314](#) for instructions.
2. Refer to [Figure 11-28](#). Remove cables W101, W102, W103, W104, and ribbon cable W91.
3. Remove the three screws (2) that attach the switch to the bracket. Lift the switch from the bracket.

#### Replacement

1. Attach the switch to the bracket using the three screws (2) removed earlier. Torque to 6 inch-pounds.
2. Replace cables W101, W102, W103, and W104. Torque to 9 inch-pounds.
3. Replace ribbon cable W91.
4. Replace the front frame.

**Option 123 Assemblies**  
**E4446A, E4447A, E4448A**

**Figure 11-31 Option 123 Assembly and Cable Locations**



46\_123\_only

**A34 Mixer**

**Removal**

1. Drop the front frame. See [page 314](#) for instructions.
2. Refer to [Figure 11-31](#). Remove cables W93, W98, W99, and flat flex cable W90.
3. Remove the three screws (1) that attach the A34 Mixer to the standoffs.



## Replacement

1. Refer to [Figure 11-31](#). Attach the A34 Mixer to the standoffs using the three screws ( 1 ) removed earlier. Torque to 9 in-lbs.
2. Replace cables W93, W98, and W99. Torque to 10 in-lbs.
3. Replace flat flex cable W90.
4. Replace the front frame.

## A35 Mixer Bias Board

### Removal

1. Drop the front frame. See [page 314](#) for instructions.
2. Refer to [Figure 11-31](#). Remove flat flex cable W90.
3. Remove the four screws ( 3 ) that attach the A35 Mixer Bias board to the bracket.

### Replacement

---

**NOTE**

The A35 Mixer Bias board must have a self-adhesive thermal pad attached to the voltage regulator (the square black component near the center of the board). This thermal pad transfers heat from the voltage regulator in the back side of the board to the sheet metal chassis. When replacing the mixer bias board, discard the old thermal pad and replace it. To install a replacement thermal pad, peel off the protective cover from the pink side of the pad and attach to the voltage regulator. Peel off the other protective cover on the pad and carefully align the board over the mounting holes and secure with screws.

---

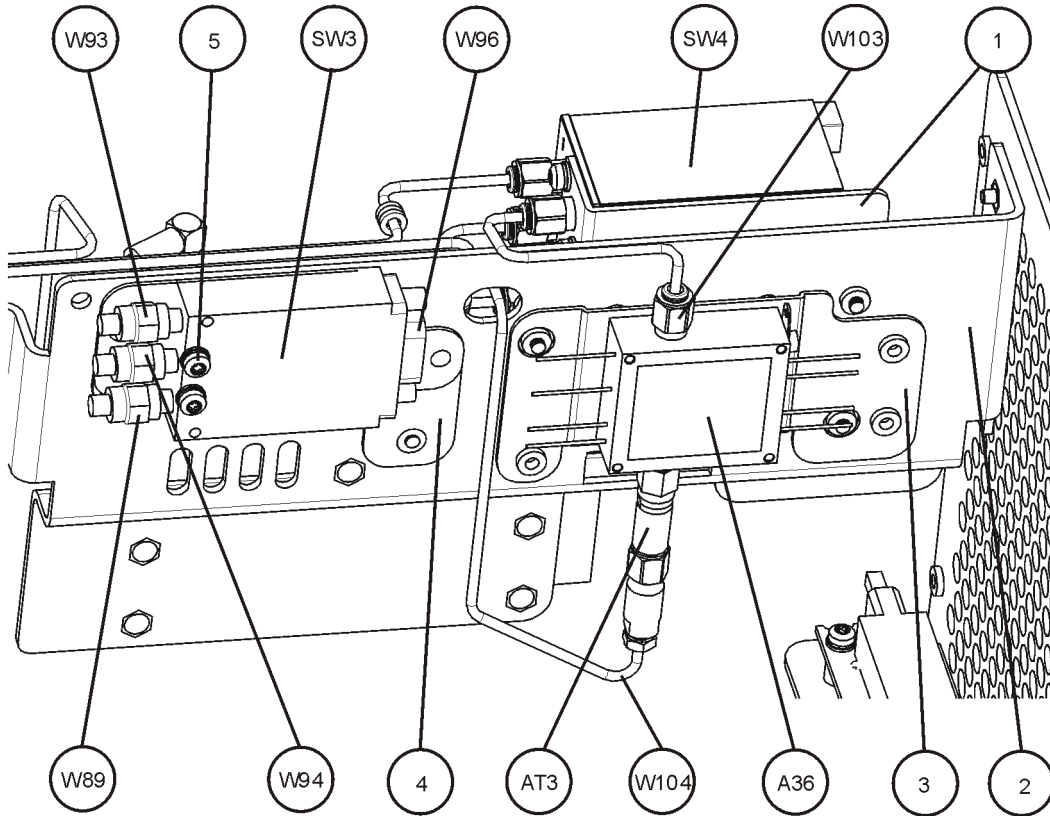
1. Refer to [Figure 11-31](#). Attach the A35 Mixer Bias board to the bracket using the four screws ( 3 ) removed earlier. Torque to 9 in-lbs.
2. Replace flat flex cable W90.
3. Replace the front frame.

## SW3 Switch

### Removal

1. Drop the front frame. See [page 314](#) for instructions.
2. Refer to [Figure 11-32](#). Remove cables W89, W93, W94, and ribbon cable W96.

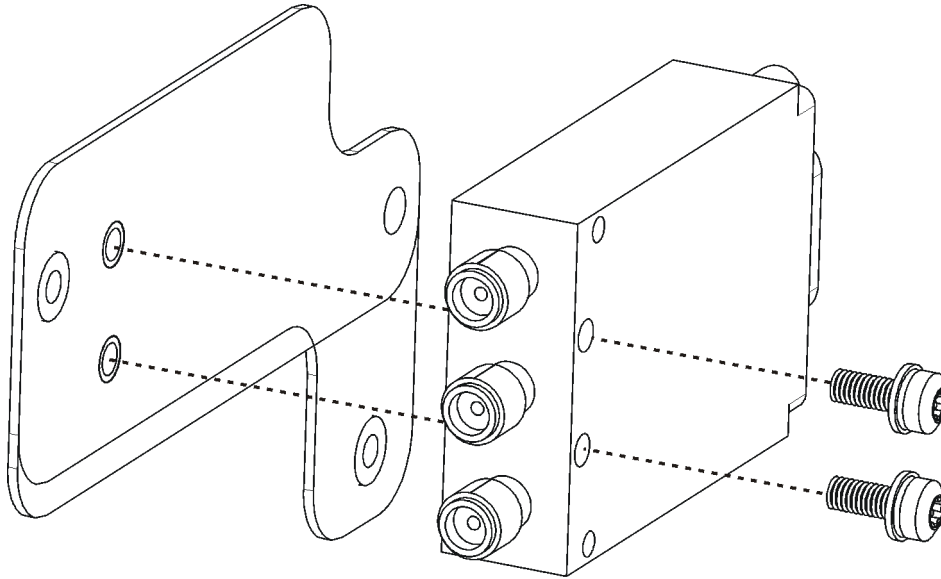
**Figure 11-32 SW3 Removal**



46\_110\_123\_rear

3. Refer to [Figure 11-31](#). Remove the two screws (4) that attach the SW3 bracket to the main bracket. Lift the switch/bracket assembly from the instrument.
4. Refer to [Figure 11-33](#). To separate the switch from the bracket, remove the two screws.

**Figure 11-33 SW3 and Bracket**



sw3\_bracket

### **Replacement**

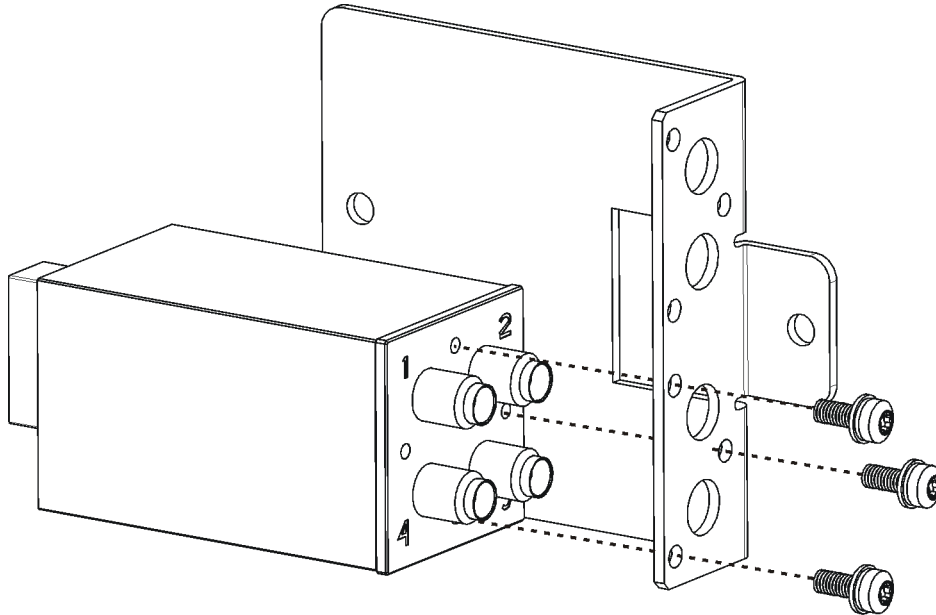
1. Attach SW3 to the bracket using the two screws removed earlier. Torque to 9 in-lbs.
2. Place the switch/bracket assembly into place on the main bracket. Refer to [Figure 11-31](#). Replace the two screws (4) that attach the SW3 bracket to the main bracket. Torque to 9 inch-pounds.
3. Refer to [Figure 11-32](#). Replace cables W89, W93, and W94. Torque to 9 in-lbs.
4. Replace ribbon cable W96.
5. Replace the front frame.

### **SW5 Switch**

#### **Removal**

1. Drop the front frame. See [page 314](#) for instructions.
2. Refer to [Figure 11-31](#). Remove cables W99, W100, W105 and ribbon cable W92.
3. Remove the three screws (2) that attach SW5 to the bracket. Lift the switch/bracket assembly from the instrument.
4. Refer to [Figure 11-34](#). To separate the switch from the bracket, remove the three screws.

**Figure 11-34 SW5 and Bracket**



sw5\_bracket

### **Replacement**

1. Attach SW5 to the bracket using the three screws removed earlier. Torque to 6 in-lbs.
2. Place the switch/bracket assembly into place on the main bracket. Refer to [Figure 11-31](#). Replace the two screws (2) that attach the SW5 bracket to the main bracket. Torque to 9 inch-pounds.
3. Replace cables W99, W100, and W105. Torque to 10 inch-pounds.
4. Replace ribbon cable W92.
5. Replace the front frame.

## Attenuator Assembly E4440A, E4443A, E4445A

---

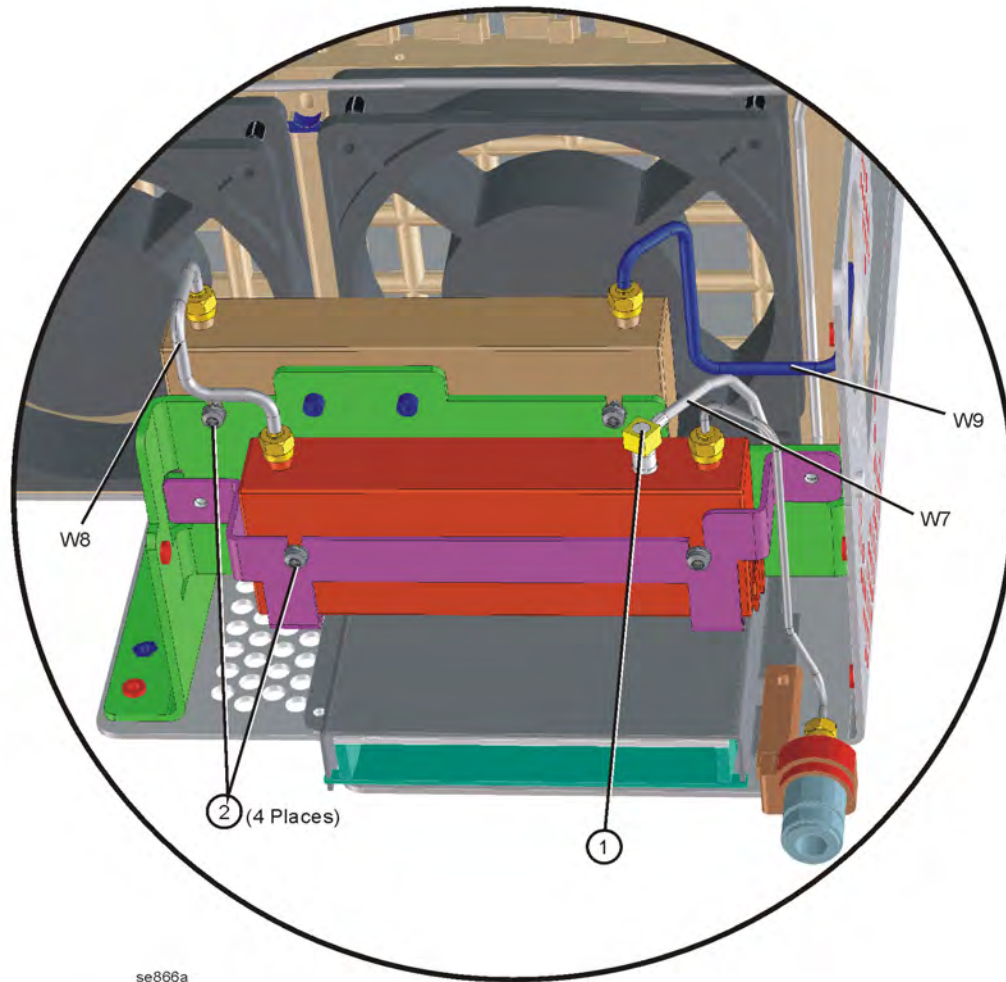
**CAUTION**

Use ESD precautions when performing this replacement procedure.

### Removal

1. If you haven't already done so, remove the instrument outer case and top brace. Refer to the [“Instrument Outer Case”](#) and the [“Top Brace”](#) removal procedures.
2. Drop the front frame. Refer to the [“Front Frame”](#) section.
3. Unplug the ribbon cables from the attenuators.
4. Refer to [Figure 11-35](#). Unplug the coaxial cable W20 from the locations marked (1).
5. Remove the semi-rigid cables W7 and W9.
6. Using the T-10 driver, remove the 4 screws (2).
7. The attenuator assembly can now be removed from the deck.

**Figure 11-35 Attenuator Assembly Removal (E4440A, E4443A, E4445A)**



se866a

## Replacement

1. Position the attenuator assembly in the deck.
2. Using the T-10 driver, replace the 4 screws, but do not torque.
3. Replace the semi-rigid cables to the correct locations. Torque the cables to 10 inch pounds.
4. Torque the screws to 9 inch pounds.
5. Replace the coaxial cable.
6. Dress the ribbon cables between the fan and deck and clip, and reconnect to the correct locations.
7. Replace the front frame. Refer to the [“Front Frame”](#) section.
8. Replace the instrument top brace and outer case. Refer to the [“Top Brace”](#) and the [“Instrument Outer Case”](#) replacement procedures.

## Attenuator Assembly E4446A, E4447A, E4448A

---

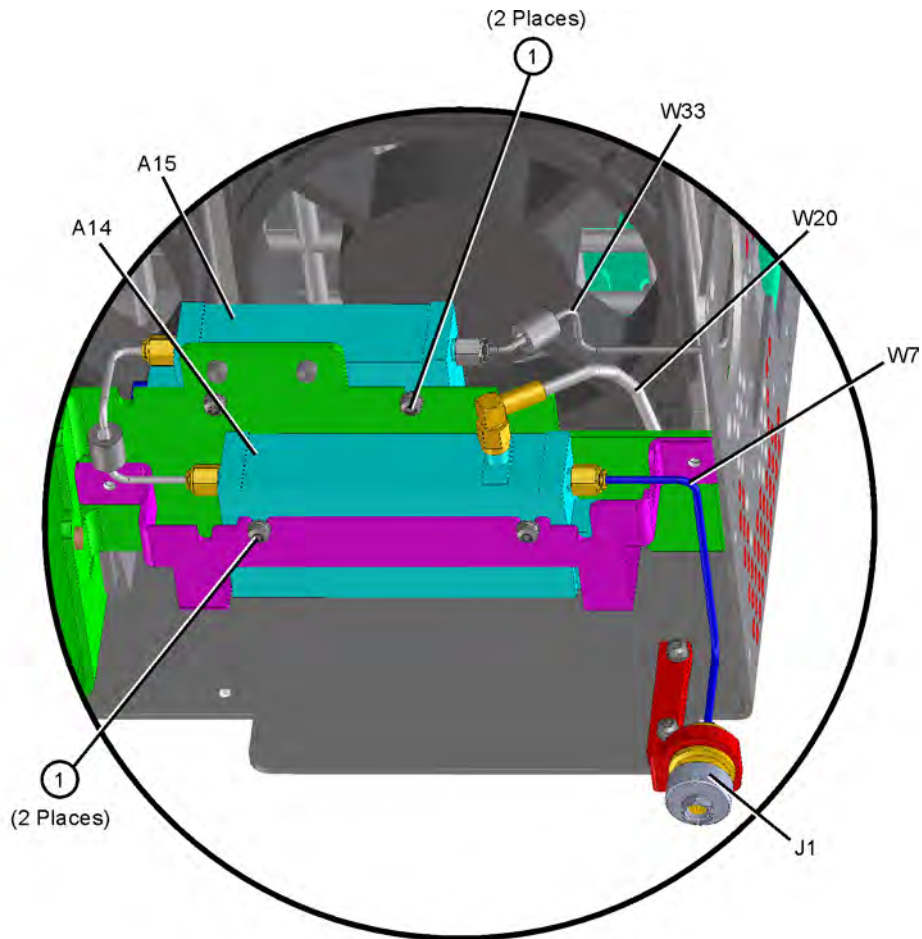
**CAUTION**

Use ESD precautions when performing this replacement procedure.

### Removal

1. If you haven't already done so, remove the instrument outer case and top brace. Refer to the [“Instrument Outer Case”](#) and the [“Top Brace”](#) removal procedures.
2. Drop the front frame. Refer to the [“Front Frame”](#) section.
3. Unplug the ribbon cables from the attenuators.
4. Refer to [Figure 11-36](#). Unplug the coaxial cable W20 from the locations marked (1).
5. Remove the semi-rigid cables W7 and W33.
6. Using the T-10 driver, remove the 4 screws (2).
7. The attenuator assembly can now be removed from the deck.

**Figure 11-36 Attenuator Assembly Removal (E4446A, E4448A)**



sn516a

## Replacement

1. Position the attenuator assembly in the deck.
2. Using the T-10 driver, replace the 4 screws, but do not torque.
3. Replace the semi-rigid cables to the correct locations. Torque the cables to 10 inch pounds.
4. Torque the screws to 9 inch pounds.
5. Replace the coaxial cable.
6. Dress the ribbon cables between the fan and deck and clip, and reconnect to the correct locations.
7. Replace the front frame. Refer to the [“Front Frame”](#) section.
8. Replace the instrument top brace and outer case. Refer to the [“Top Brace”](#) and the [“Instrument Outer Case”](#) replacement procedures.



---

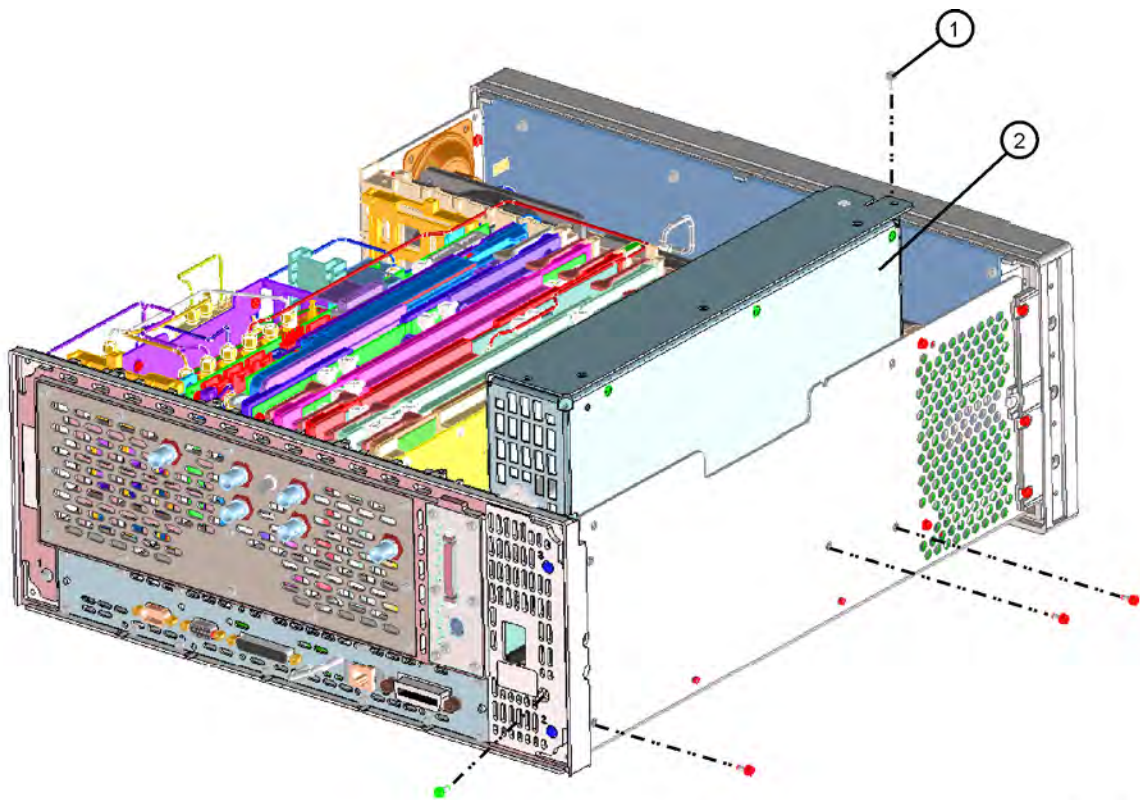
## A5 Power Supply

**CAUTION** Use ESD precautions when performing this replacement procedure.

### Removal

1. Remove the instrument top brace. Refer to the “[Top Brace](#)” removal procedure.
2. Refer to [Figure 11-37](#). Using the T-10 driver, remove the 5 screws (1) securing the A5 power supply assembly (2) to the deck and the rear frame.
3. Carefully pull up on the power supply assembly to disengage from the motherboard connector.

**Figure 11-37** Power Supply Removal



se87a

## Replacement

1. Place the power supply assembly into position in the deck. Push down to mate the assembly with the motherboard connector.
2. Refer to [Figure 11-37](#). Using the T-10 driver, replace the 5 screws. Torque to 9 inch pounds.
3. Replace the instrument top brace. Refer to the [“Top Brace”](#) replacement procedure.

---

## A39 USB/Memory Board

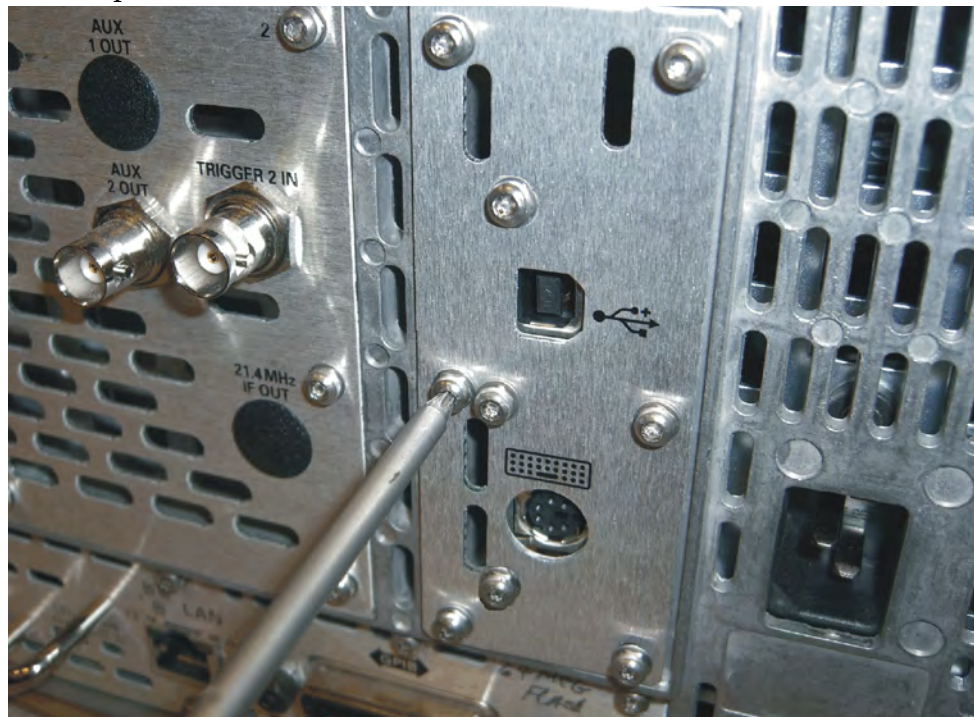
---

### CAUTION

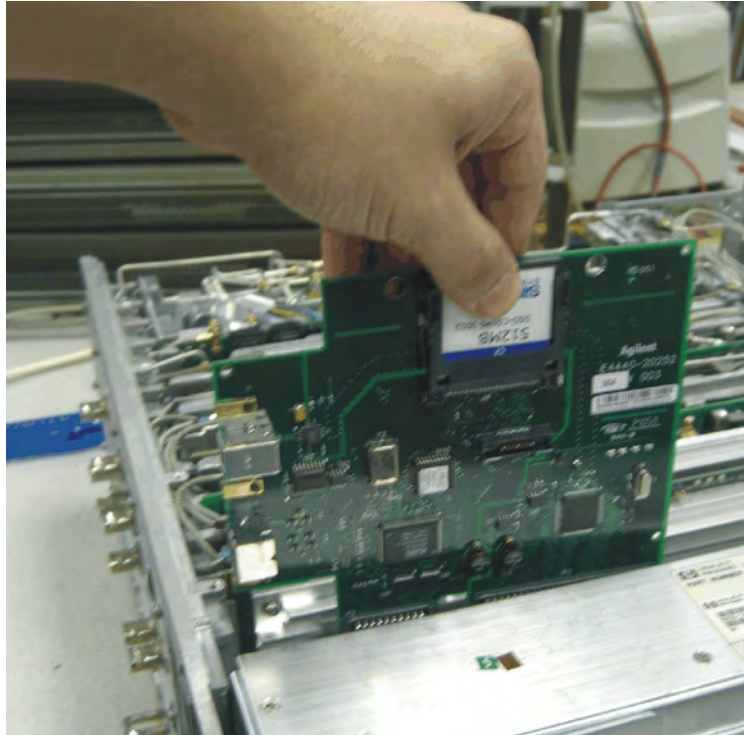
Use ESD precautions when performing this replacement procedure.

### Removal

1. Remove the instrument top brace. Refer to the “[Top Brace](#)” removal procedure.
2. Remove the 9 screws attaching the rear plate in place on the PSA rear panel.

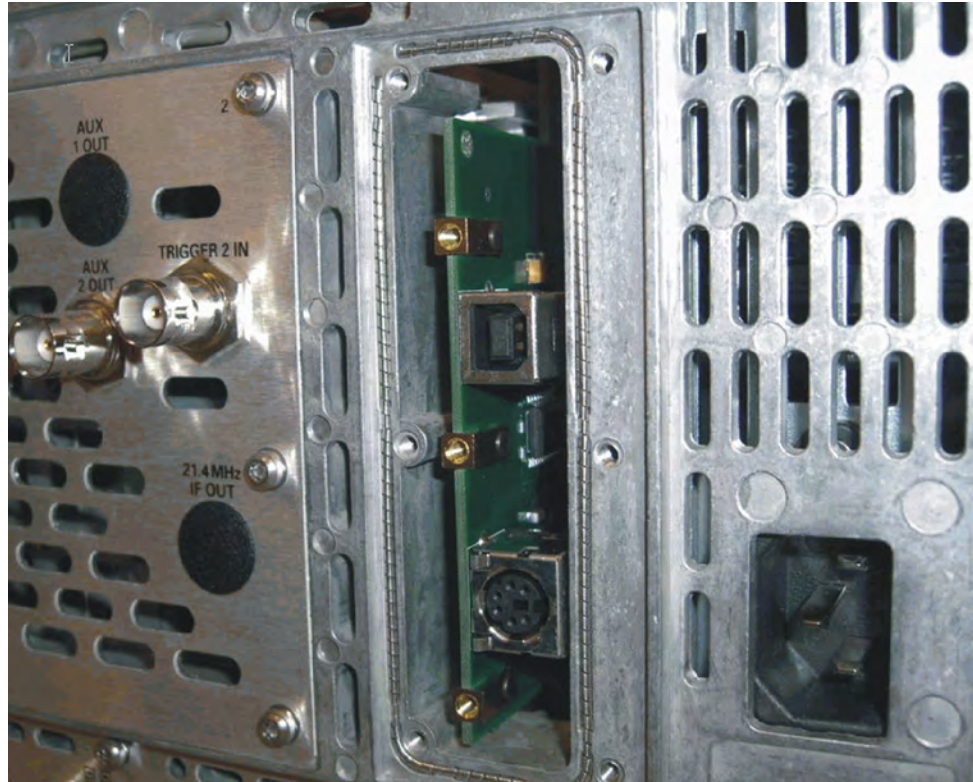


3. Remove the USB/Memory board. To do this, gently lift the board vertically from its socket on the PSA motherboard.



## Replacement

1. Insert the USB/Memory board, making sure to firmly insert the connectors into the PSA motherboard sockets, but do not exert so much force as to break the connector.
2. After installation, the memory board should look like this:



3. Put the rear plate in place on the PSA rear panel, and screw it into place.
4. Replace the instrument top brace. Refer to the [“Top Brace”](#) replacement procedure.

---

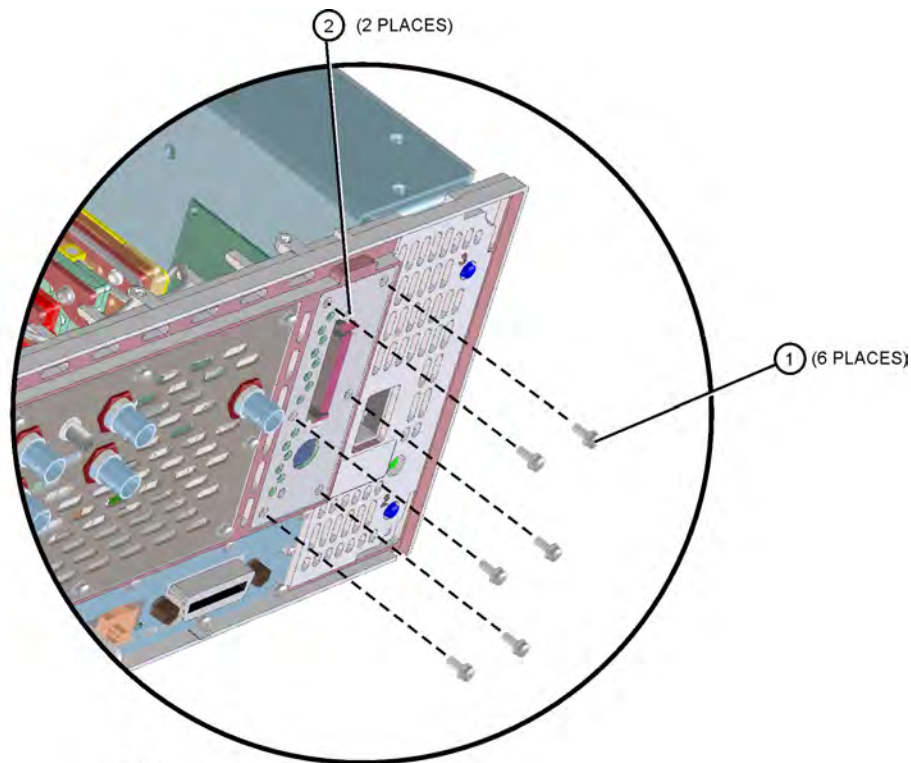
## A6 SCSI Board

**CAUTION** Use ESD precautions when performing this replacement procedure.

### Removal

1. Refer to [Figure 11-38](#). At the rear of the instrument, use a T-10 driver to remove the 6 screws (1) securing the small panel to the frame.
2. The SCSI board can be removed through the rear panel by pulling up on the board to disengage it from the CPU board.

**Figure 11-38** SCSI Board Removal



### Replacement

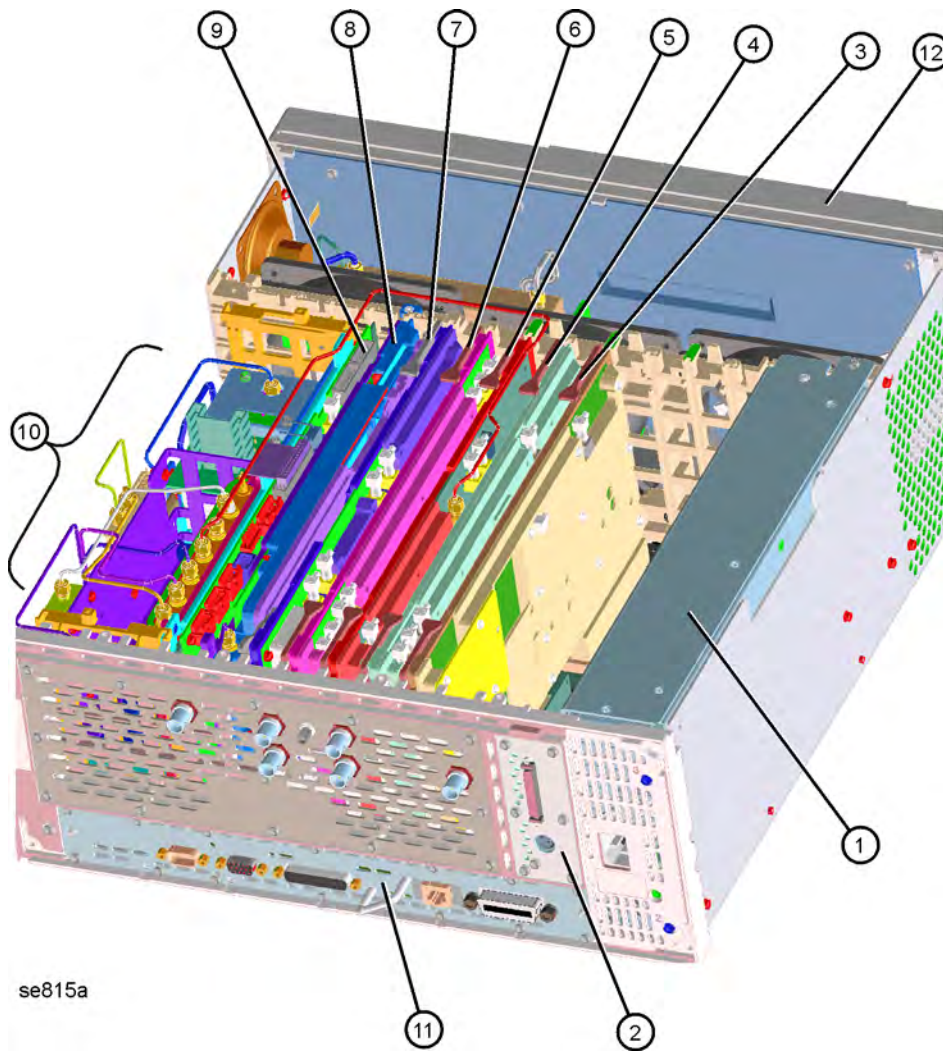
1. Replace the SCSI board by inserting it into the opening on the rear frame. Carefully position the board in the CPU board connector and push down to mate.
2. Replace the panel onto the frame by replacing the 6 screws using a T-10 driver. Torque to 9 inch pounds.

## Vertical Board Assemblies (Standard Instrument)

**CAUTION** Use ESD precautions when performing this replacement procedure.

Figure 11-39 shows the location of the vertical board assemblies.

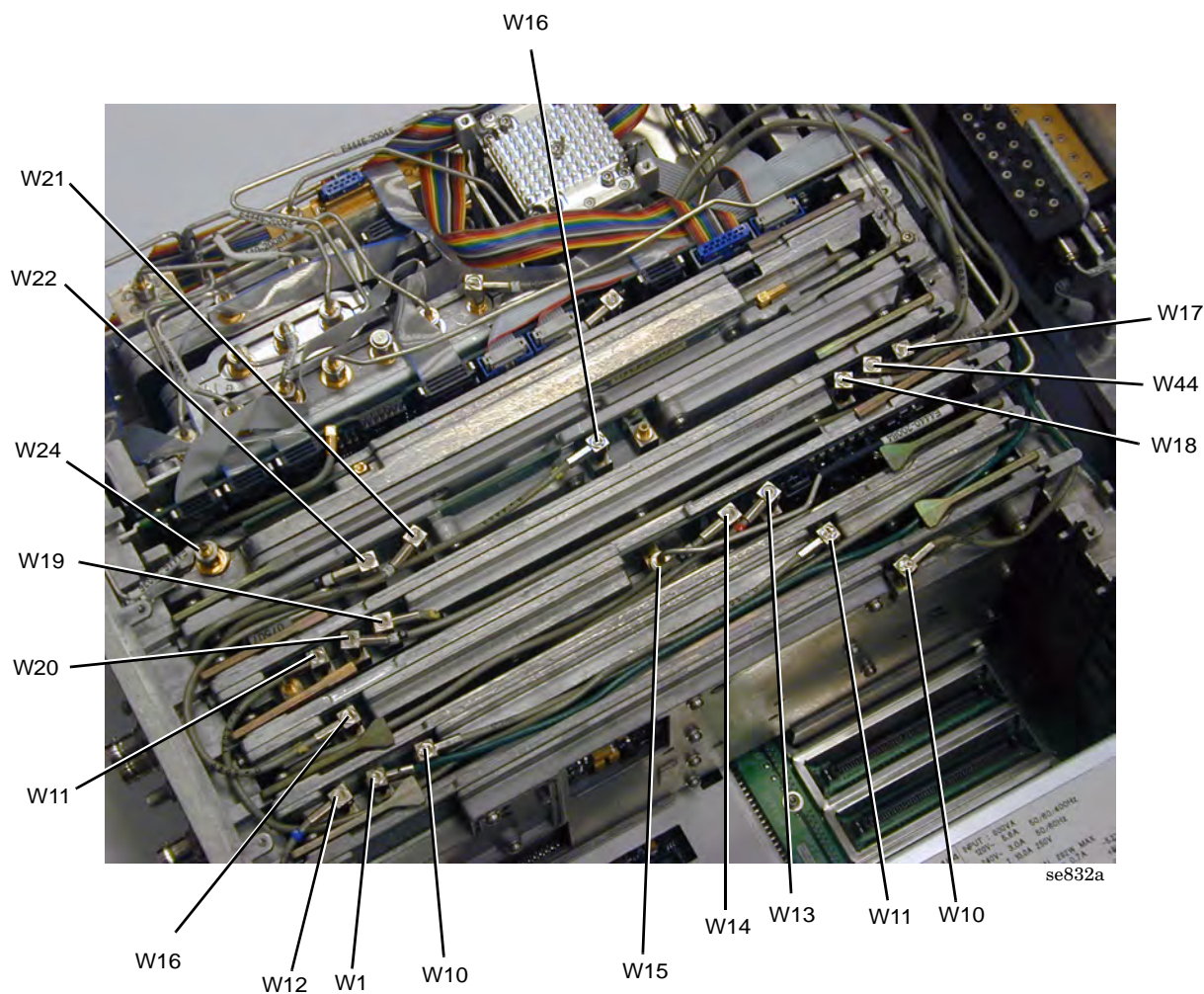
**Figure 11-39** Vertical Board Assembly Locations



Assembly Replacement Procedures  
**Vertical Board Assemblies (Standard Instrument)**

Item	Description	Item	Description
1	A5 Power Supply	6	A10 3rd Converter Assembly
2	A6 SCSI Interface Board or A39 USB/Memory Board	7	A11 Reference Assembly
3	A7 Digital IF Assembly	8	A12 LO Synthesizer Assembly
4	A8 Analog IF Assembly	9	A13 Front End Driver Board
5	A9 2nd LO/ Fan Control Assembly		

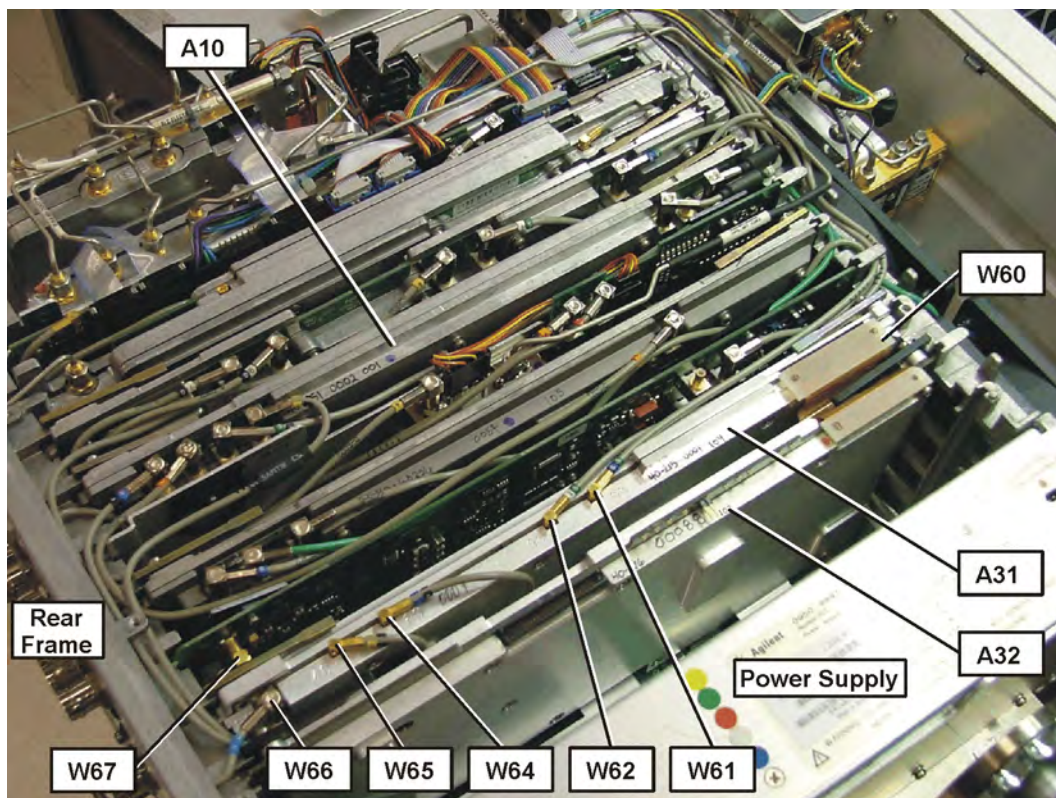
**Figure 11-40 Vertical Board Assembly Cables**





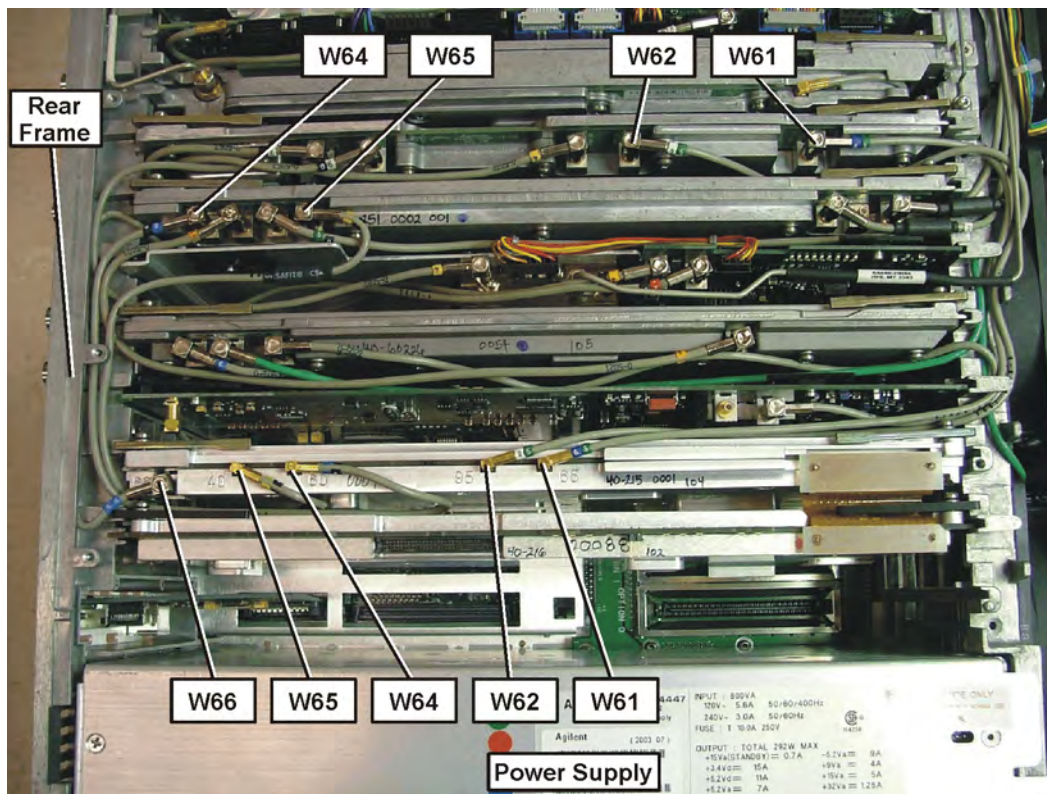
Description
W1 Cable (5), coax, Front Panel External Trigger to A8 Analog IF Assy. P1
W10 Cable (8), coax, 7.5 MHz from A8 Analog IF P2, to A7 Digital IF, P1
W11 Cable (3), coax, 21.4 MHz from A10 3rd Converter J5 to A8 Analog IF, J13
W12 Cable (6), coax, TRIGGER IN from rear panel to A8 Analog IF, P4
W13 Cable (20), coax, TRIGGER 1 OUT to A9 2nd LO, J12
W14 Cable (30), coax, TRIGGER 2 OUT to A9 2nd LO, J11
W15 Cable, semi-rigid, A9 2nd LO, J10 to Lowband, J5
W16 Cable (4), coax, 600 MHz from A11 Reference board P3 to A9 2nd LO, J1
W17 Cable (10), coax (with ferrites), A19 RYTHM highband output to A10 3rd Converter J1
W18 Cable (7), coax (with ferrites), 321.4 MHz A20 Lowband assy to A10 3rd Converter J2
W18 Cable (E4447A only). This cable is permanently attached to the A10 3rd Converter
W19 Cable (40), coax 321.4 MHz IF OUT from A10 3rd Converter J4 to rear panel
W20 Cable (50), coax, 50 MHz Cal signal from A10 3rd Converter J7 to A14 Attenuator
W21 Cable (90), coax, 10 MHz Out from A11 Reference Assy P2 to rear panel
W22 Cable (70), coax, Ext Ref In from rear panel to A11 Reference Assy P1
W24 Cable, semi-rigid, A21 SLODA to A12 Synthesizer (E4440A, 43A, 45A) W24 Cable, semi-rigid, A21 SLODA to A12 Synthesizer (E4446A, 47A, 48A)
W44 Cable (9), coax, IF IN from front-panel to A10 3rd Converter J3 (Option AYZ)

**Figure 11-41 Option 122 or 140 Assembly and Cable Locations**



Reference Designator	Description	Agilent Part Number
A10	A10 3rd Converter Assembly	E4440-60261
A31	A31 Wideband Analog IF Assembly (Option 122 or 140)	E4440-60215
A32	A32 Wideband Digital IF Assembly (Option 122 or 140)	E4440-60262
W60	W60 Cable, ribbon, ADC Data from A31 WB Analog IF to A32 WB Digital IF (Option 122 or 140)	E4440-60341
W61	W61 Cable (65), coax, 100 MHz Ref from A11 Reference Assembly to A31 WB Analog IF (Option 122 or 140)	8121-1007
W62	W62 Cable (95), coax, 300 MHz Ref from A11 Reference Assembly P4 to A31 WB Analog IF (Option 122 or 140)	8120-8863
W64	W64 Cable (60), coax, WB IF CA:L from A31 WB Analog IF to A10 3rd Converter J6 (Option 122 or 140)	8121-1007
W65	W65 Cable (40), coax, 321.4 MHz IF from A10 3rd Converter J4 to A31 WB Analog IF (Option 122 or 140)	E4440-60343
W66	W66 Cable (66), coax, 321.4 MHz from A31 WB Analog IF to Rear Panel (Option 122 or 140)	8121-1323

Figure 11-42 Option 122 or 140 Cable Routing



## Removal

If you haven't already done so, remove the instrument outer case and top brace. Refer to the [“Instrument Outer Case”](#) and the [“Top Brace”](#) removal procedures.

To remove any of the vertical board assemblies, it will be necessary to remove the cables attached to that assembly. After the cables are removed, pull up on the ejector tabs to unseat the board from the motherboard connector, then slide the board up to remove it from the deck.

---

### NOTE

For E4447A A10 3rd Converter assembly, the cable on J2 cannot be removed! See below for the 3rd Converter removal procedure.

For Option 122 or 140 assemblies and cables, see [Figure 11-41](#). Remove W60 ribbon cable before removing either A31 or A32 assemblies.

To remove the A12 LO Synthesizer assembly, it will also be necessary to remove the cable hold down wire (single screw), and the two screws attaching the assembly to the midweb and deck.

## A10 Third Converter Removal Procedure (E4447A only)

### Removal

1. Remove the A13 Front End Driver, A12 Synthesizer, and A11 Reference assemblies. The cable hold down wire will need to be removed in order to remove the Synthesizer assembly.
2. Refer to [Figure 11-24](#). Remove the semi-rigid cables W15, W37, W39, W41, W54, W55, and W56. Cable W18 will be removed when the A20 Lowband and A30 FIFA are separated.
3. Refer to [Figure 11-25](#). Using the T-10 driver, remove the 2 screws (4) that attach the Lowband assembly to the instrument. the Lowband and FIFA assemblies can now be removed from the RF section as a unit.
4. Separate the FIFA from the Lowband assembly by removing the 2 screws (7).
5. Remove the bracket from the Lowband assembly. This allows cable W18 to be removed from the Lowband assembly.
6. Carefully pull the W18 cable through the hole in the RF deck shield. Remove the 3rd Converter assembly from the instrument.

### Replacement

1. Install the 3rd Converter assembly and assure the flexible coax cable W18 from the 3rd Converter is routed through the hole in the RF deck shield. Connect the cable to the Lowband assembly.
2. Replace the bracket on the Lowband assembly, and attach the FIFA to the bracket. Torque the screws to 9 inch pounds.
3. Place the Lowband and FIFA assemblies into position in the RF section and attach with the two screws removed in [step 4](#) above.
4. Replace all semi-rigid cables removed from the RF section. Torque to 10 inch pounds.
5. Assure the flexible coax cable from the Lowband to the 3rd Converter is routed along the motherboard so it will not get damaged when the 3 assemblies removed earlier are replaced. Also, assure there is no slack in the cable from the Lowband connector to where the cable goes through the RF section shield.
6. Replace the 3 board assemblies, attach all cables, and the cable hold down wire.

### Replacement

1. Slide the assembly down in the correct front and rear guide slots.

Refer to the silkscreened locations on the motherboard or the top brace to ensure correct placement of the assemblies. Hook the ejectors under the tabs on the rear frame and mid web. Carefully push down on the ejectors to mate the assembly with the motherboard connectors. If the A7 Digital IF ejector handles do not lay flat against the assembly casting, the assembly may not be inserted fully and may cause EEPROM self-test failures.

2. Reconnect the cables that were removed. Refer to the silk-screen on the instrument top brace, along with the matching numbers on the cables and near the connectors on the boards, for correct placement of cables. Torque any semi-rigid cables to 10 inch pounds. Take care to dress the cables correctly so they aren't pinched when the top brace is replaced.

For correct routing of Option 122 or 140 cables, refer to [Figure 11-42 on page 371](#).

3. If the A12 LO Synthesizer assembly was removed, replace the two screws and torque to 9 inch pounds. Replace the cable hold down by inserting the end into the hole in the Midweb and secure it with the single screw. Torque to 9 inch pounds.
4. Replace the instrument top brace and outer case. Refer to the "[Top Brace](#)" and the "[Instrument Outer Case](#)" replacement procedures.

## Fans/Mid Web

---

**NOTE** The fans are attached to a part of the instrument known as the mid web. It is possible to remove a fan without removing the mid web from the instrument. The 3 fans in the instrument can be replaced individually. It will be necessary to remove other assemblies located near the fan to be replaced.

---

**CAUTION** Use ESD precautions when performing this replacement procedure.

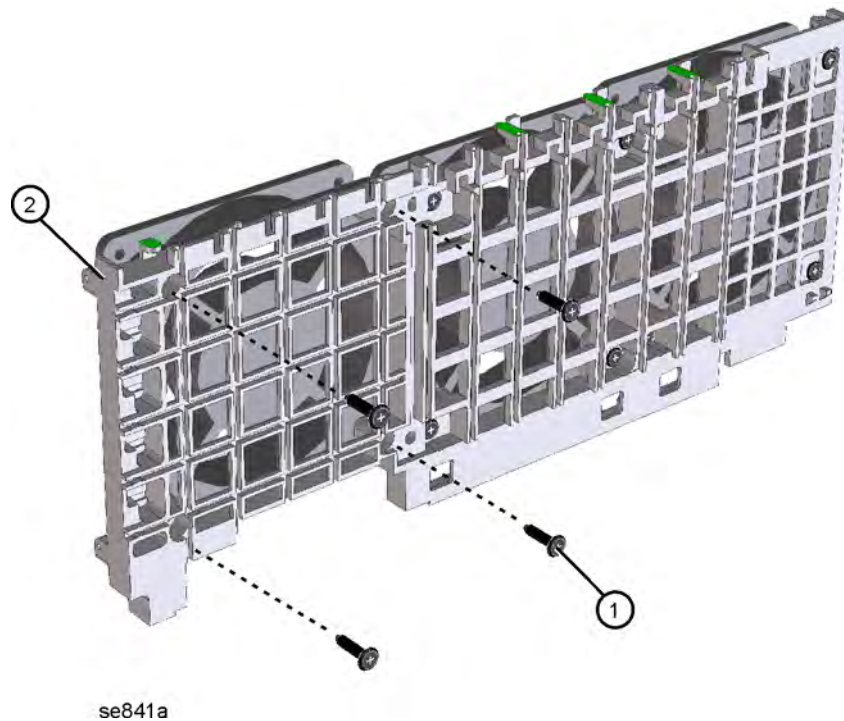
---

### Fans

#### Fan Removal

1. Remove the instrument top brace. Refer to the “[Top Brace](#)” removal procedure.
2. Drop the front frame. Refer to the “[Drop the Front Frame](#)” procedure.
3. Remove any assemblies necessary to access the rear of the midweb where the defective fan is located. You will need to access the rivets as shown in [Figure 11-43](#). Refer to the removal procedures for the power supply, the vertical board assemblies, or the RF section as needed.
4. Unplug the appropriate fan cable from the motherboard.
5. Refer to [Figure 11-43](#). To remove a fan, it is necessary to remove the 4 plastic rivets (1) that attach it to the mid-web (2). To do this use a small tool such as a punch or screwdriver to push the rivet out.
6. Once the rivets are removed, the fan can be lifted from the mid web.
7. Remove the fan guard if available.

**Figure 11-43 Fan Removal**



se841a

### Fan Replacement

1. Place the new fan on the mid-web, assuring the arrow on the fan is pointing toward the mid-web and the fan cables are positioned so they won't interfere with the fan operation or airflow.
2. Install the 4 plastic rivets that secure the fan to the mid-web. With the rivets center posts raised, press the rivets through the mid web and into the fan. Press down on the center post to snap the rivets into place.
3. Replace the fan guard.
4. Replace any assemblies that were removed for access to the fan.
5. Plug the fan cables into the motherboard.
6. Replace the front frame assembly. Refer to the [“Front Frame”](#) replacement procedure.
7. Replace the instrument top brace. Refer to the [“Top Brace”](#) replacement procedure.

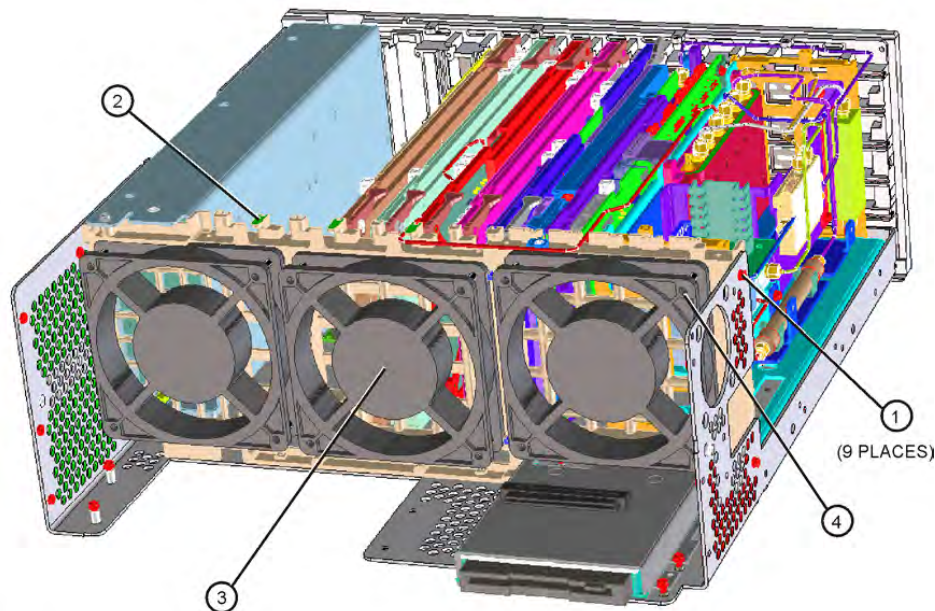
## Mid Web

To completely remove the mid web, perform the following steps:

### Removal

1. Remove the instrument top brace. Refer to the “[Top Brace](#)” removal procedure.
2. Drop the front frame. Refer to the “[Drop the Front Frame](#)” procedure.
3. Remove the attenuator assembly. Refer to the “[Attenuator Assembly E4440A, E4443A, E4445A](#)” removal procedure.
4. Remove the A5 power supply. Refer to the “[A5 Power Supply](#)” removal procedure.
5. Remove the vertical board assemblies. Refer to the “[Vertical Board Assemblies \(Standard Instrument\)](#)” removal procedure.
6. Refer to [Figure 11-44](#). Undress the coaxial cables from the cable guide in the mid-web.
7. Using the T-10 driver, remove the 9 screws (1) that secure the mid-web/fan assembly (2) to the deck. Note this includes 5 screws on the bottom of the instrument. Refer to [Figure 11-47 on page 383](#) and remove the screws (1).
8. Unplug the 3 fan connectors from the motherboard.
9. Lift the mid-web/fan assembly from the deck.

**Figure 11-44 Mid-Web/Fan Assembly Removal**



se88a



## Replacement

1. Place the mid-web into position in the deck with the fans on the front side of the instrument. Take care to avoid pinching any cables or wires underneath the mid web.
2. Using the T-10 driver, replace the 9 screws that secure the mid-web/fan assembly to the deck. Torque to 9 inch pounds.
3. Plug the 3 fan connectors into the motherboard.
4. Replace the cables that were removed. Torque any semi-rigid cables to 10 inch pounds.
5. Replace the power supply. Refer to the [“A5 Power Supply”](#) replacement procedure.
6. Replace the vertical board assemblies. Refer to the [“Vertical Board Assemblies \(Standard Instrument\)”](#) replacement procedure.
7. Replace the attenuator assembly. Refer to the [“Attenuator Assembly E4440A, E4443A, E4445A”](#) replacement procedure.
8. Redress the cables in the mid-web so they will not be pinched under the top brace or interfere with any fan operation.
9. Replace the front frame assembly. Refer to the [“Front Frame”](#) replacement procedure.
10. Replace the instrument top brace. Refer to the [“Top Brace”](#) replacement procedure.

## A23 Disk Drive

---

**CAUTION** Use ESD precautions when performing this replacement procedure.

---

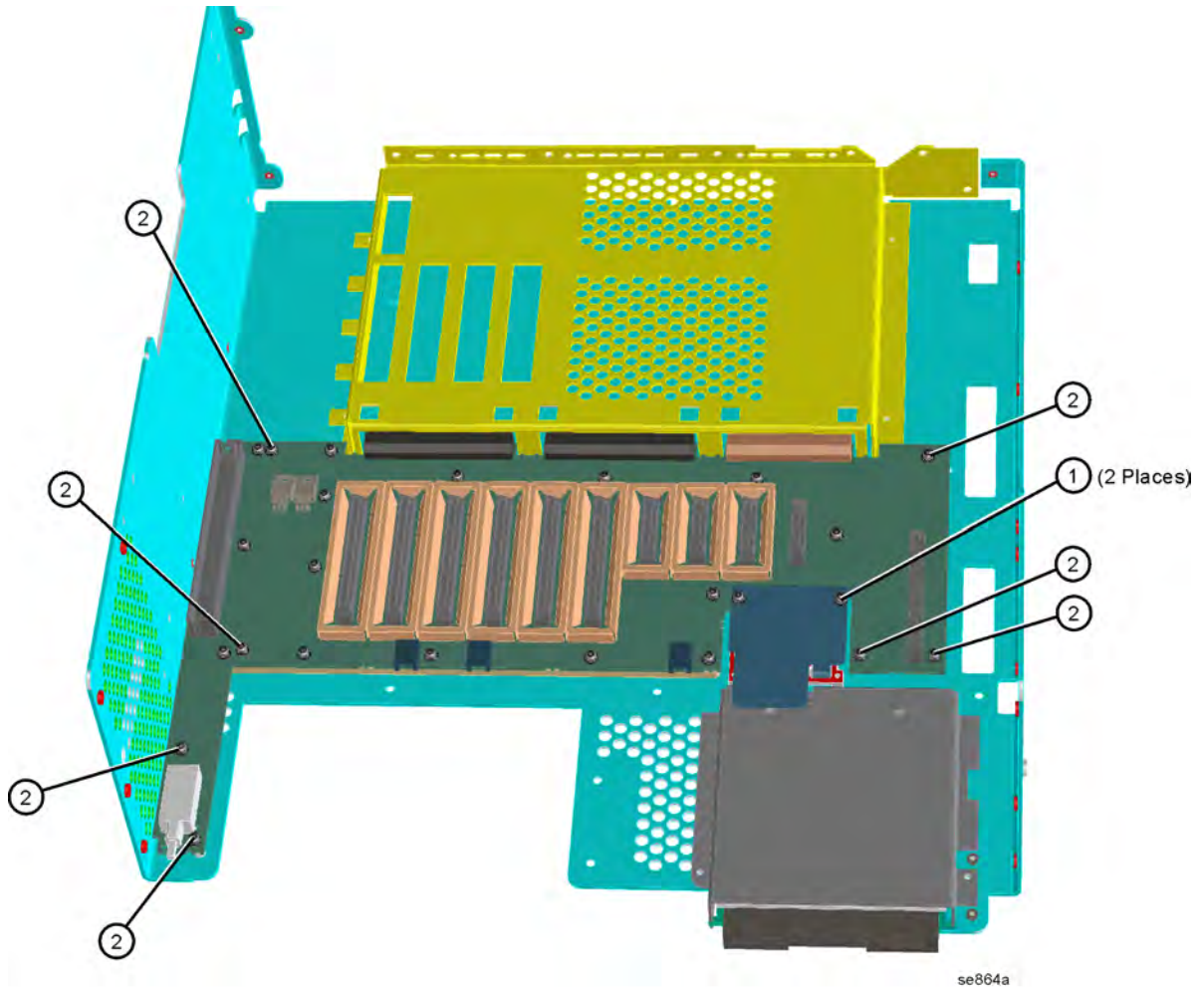
**NOTE** The A23 disk drive assembly consists of the disk drive, disk drive board, and disk drive mount. These are removed from the instrument as a unit, but they can be replaced separately.

---

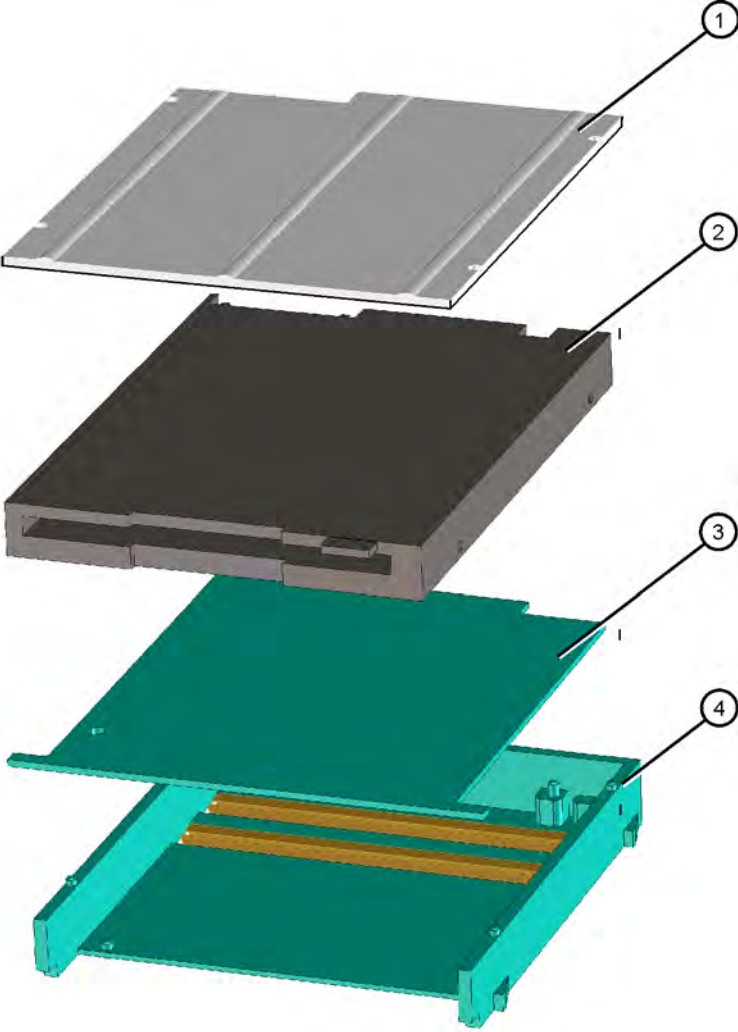
### Removal

1. Remove the instrument top brace. Refer to the “[Top Brace](#)” removal procedure.
2. Remove the front frame. Refer to the “[Front Frame](#)” removal procedure.
3. Remove the RF section. Refer to the “[RF Section E4440A, E4443A, E4445A](#)” removal procedure.
4. Unplug the front frame ribbon cable from the motherboard.
5. Refer to [Figure 11-45](#). Using the T-10 driver, remove the 2 screws (1) that attach the disk drive cover to the deck.
6. Unplug the flat flex cable from the motherboard connector. It is necessary to unlock this connector before removing the cable.
7. Remove the ferrite block from the cable.
8. The disk drive assembly can now be pulled out of the chassis.
9. To separate the disk drive board from the disk drive, refer to [Figure 11-46](#). Remove the top part of the disk drive mount (1). The disk drive (2) and the disk drive board (3) can now be lifted out of the bottom part of the mount (4).
10. Remove the flat flex cable from the disk drive by unlocking the connector on the drive.

**Figure 11-45** Disk Drive and Motherboard Removal



**Figure 11-46**     **Disk Drive Board Removal**



se837a

## Replacement

1. To install the disk drive board (3) into the mount, align the pins on the mount with the hole and the slot on the board. Refer to [Figure 11-46](#).
2. Install the disk drive (2) into the mount over the pc board. Ensure the drive is located over the pin at the rear of the mount. Place the top cover of the disk mount over the 4 pins.
3. Replace the flat flex cable to the disk drive and lock the connector to secure the cable.
4. Refer to [Figure 11-45](#). Slide the disk drive assembly into the disk shield.
5. Replace the ferrite block around the flat flex cable.
6. Plug in the flat flex cable to the motherboard.
7. Using the T-10 driver, replace the 2 screws that attach the disk drive cover to the deck. Torque to 9 inch-pounds.
8. Plug the front frame ribbon cable onto the motherboard.
9. Replace the RF section. Refer to the “[RF Section E4440A, E4443A, E4445A](#)” replacement procedure.
10. Replace the front frame. Refer to the “[Front Frame](#)” replacement procedure.
11. Replace the instrument top brace. Refer to the “[Top Brace](#)” replacement procedure.

## A25 Motherboard

Removing the motherboard requires the removal of all the other assemblies in the instrument. Take care to note the locations of cables and screws for correct placement during reassembly.

---

**CAUTION** Use ESD precautions when performing this replacement procedure.

---

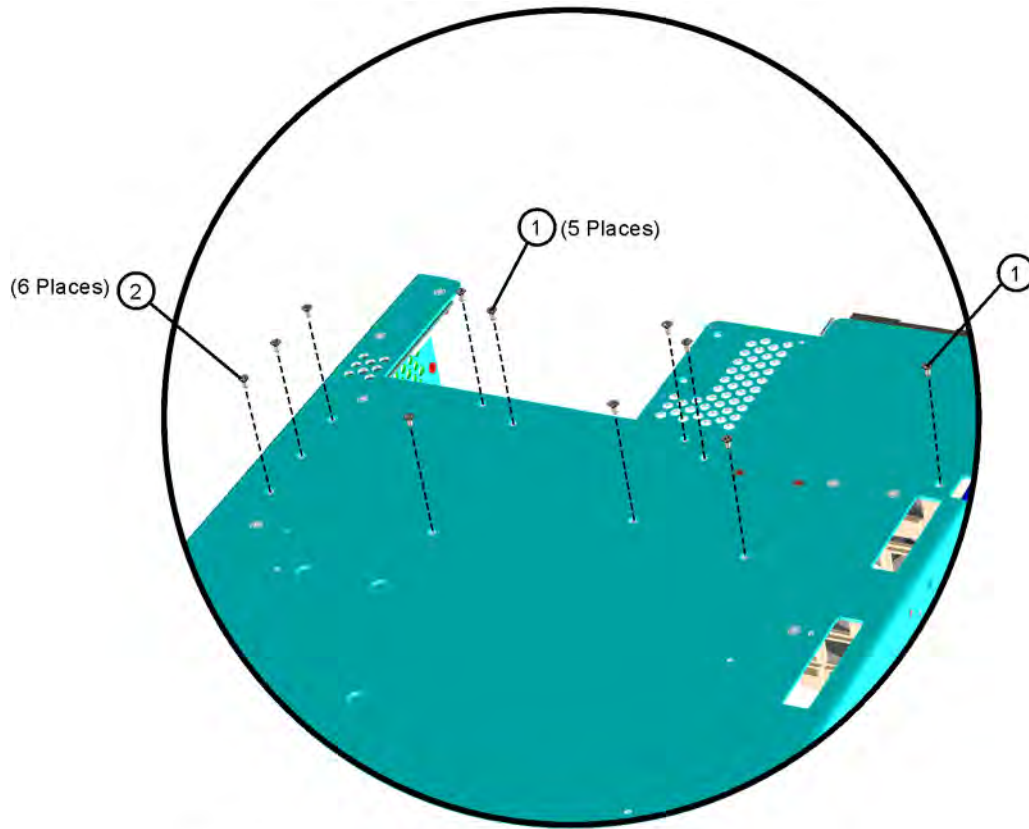
**NOTE** The motherboard assembly consists of the A25 motherboard and the MP35 motherboard shield. A replacement motherboard does not include the shield, so when you change a faulty motherboard you must transfer the shield to the new motherboard.

---

### Removal

1. Remove the instrument top brace. Refer to the [“Top Brace”](#) removal procedure.
2. Remove the front frame. Refer to the [“Front Frame”](#) removal procedure.
3. Remove the vertical assemblies. Refer to the [“Vertical Board Assemblies \(Standard Instrument\)”](#) removal procedure.
4. Remove the A5 assembly. Refer to the [“A5 Power Supply”](#) removal procedure.
5. Remove the A26 assembly. Refer to the [“A26 CPU Assembly”](#) removal procedure.
6. Remove the RF section. Refer to the [“RF Section E4440A, E4443A, E4445A”](#) removal procedure.
7. Remove the mid-web/fan assembly. Refer to the [“Fans/Mid Web”](#) removal procedure.
8. Remove the attenuator assembly. Refer to the [“Attenuator Assembly E4440A, E4443A, E4445A”](#) removal procedure.
9. Remove the W8 front panel ribbon cable from the motherboard. Detach the disk drive cover (refer to [Figure 11-45 on page 379](#)) and remove the W10 disk drive flat flex cable from the motherboard.
10. Using the T-10 driver, remove the 6 screws (2) from the bottom of the instrument as indicated in [Figure 11-47](#).
11. Refer to [Figure 11-45 on page 379](#). Remove the 7 screws (2) securing the A21 motherboard to the deck. Lift the motherboard out of the deck.

**Figure 11-47**    **Bottom Screws**



se867a

## Replacement

1. Refer to [Figure 11-45 on page 379](#). Place the motherboard into position in the deck. Using the T-10 driver, replace the screws that secure the mother board to the deck. For alignment purposes, tighten the screws in the order marked on the motherboard #1 and #2 first, then tighten the #3, #4, and #5 screws. Torque to 9 inch pounds.
2. Using the T-10 driver, replace the 6 screws on the bottom of the instrument as indicated in [Figure 11-47](#). Torque to 9 inch pounds.
3. Reattach the W10 flat flex cable and W8 ribbon cable to the motherboard.
4. Replace the mid-web/fan assembly. Refer to the “[Fans/Mid Web](#)” replacement procedure.
5. Replace the A5 assembly. Refer to the “[A5 Power Supply](#)” replacement procedure.
6. Replace the A26 assembly. Refer to the “[A26 CPU Assembly](#)” replacement procedure.
7. Replace the RF section. Refer to the “[RF Section E4440A, E4443A, E4445A](#)” replacement procedure.
8. Replace the vertical assemblies. Refer to the “[Vertical Board Assemblies \(Standard Instrument\)](#)” replacement procedure.
9. Replace the attenuator assembly. Refer to the “[Attenuator Assembly E4440A, E4443A, E4445A](#)” replacement procedure.
10. Replace the front frame assembly. Refer to the “[Front Frame](#)” replacement procedure.
11. Replace the instrument top brace. Refer to the “[Top Brace](#)” replacement procedure.



---

## A26 CPU Assembly

---

**CAUTION** Use ESD precautions when performing this replacement procedure.

---

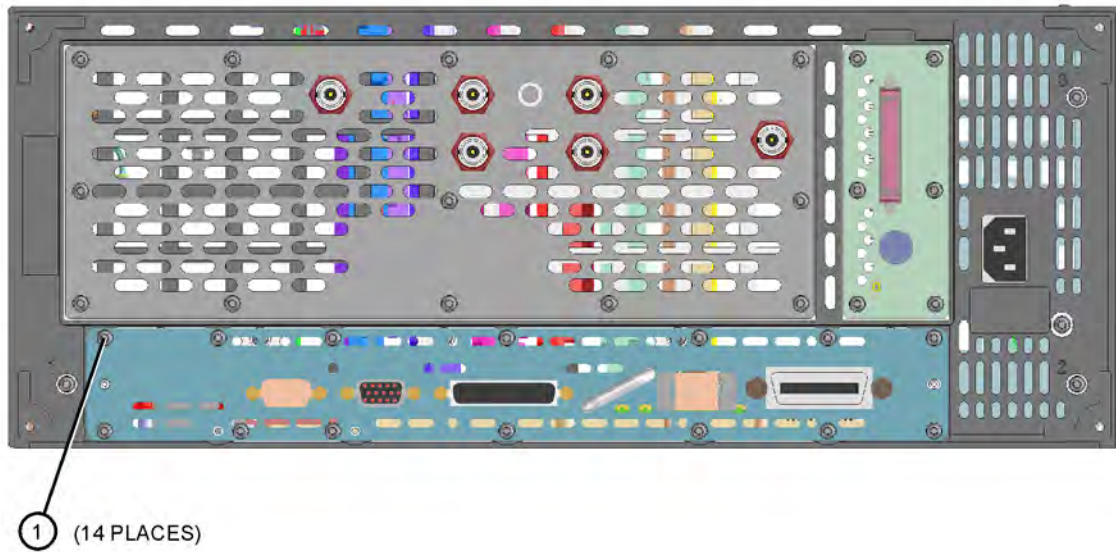
**NOTE** The CPU assembly consists of three separate boards: the A26 CPU (processor) board, the A26A1 DRAM board, and the A26A2 Flash board. The Flash memory board contains data that is pertinent to your particular instrument. If you are changing a faulty CPU board, you must transfer the three smaller boards over to the new CPU board. Refer to the [“A26A1 DRAM and A26A2 Flash Boards”](#) removal and replacement procedure. After the boards are installed on the new processor board, refer to the procedure in [Chapter 12](#) for information on transferring data to the new processor.

---

### Removal

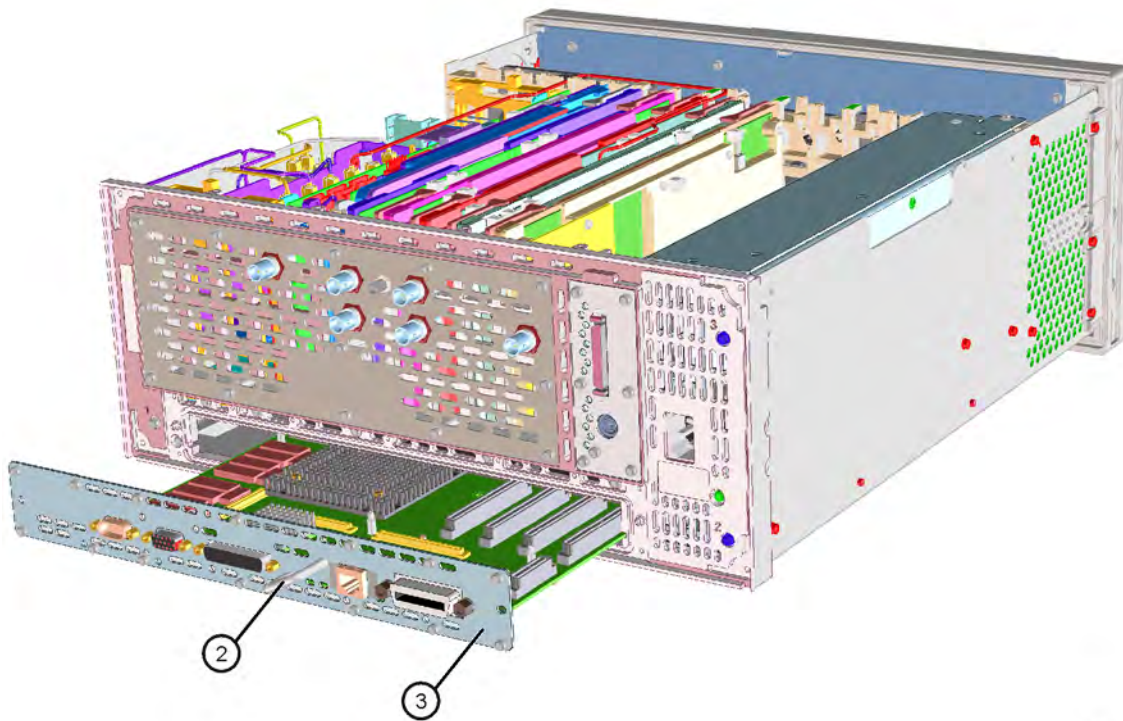
1. Remove the instrument top brace. Refer to the [“Top Brace”](#) removal procedure.
2. Remove the A7 Digital IF assembly. Refer to the [“Vertical Board Assemblies \(Standard Instrument\)”](#) removal procedure.
3. Remove the A6 SCSI board. Refer to the [“A6 SCSI Board”](#) removal procedure.
4. Using the T-10 driver, remove the 14 screws (1) from the rear panel as shown in [Figure 11-48](#).
5. Read the **Warning** on the rear dress panel before removing the CPU assembly from the deck.
6. Refer to [Figure 11-49](#). Use the handle (2) to slide the A26 assembly (3) out of the deck by pulling towards the rear of the instrument.
7. If you need to replace the battery, go to [“Battery Replacement”](#) on [page 387](#).

**Figure 11-48 CPU Screw Locations**



se840a

**Figure 11-49 CPU Assembly Removal**



se89a

## Replacement

1. Secure the A26A1 DRAM and the A26A2 Flash boards onto the new processor board. Refer to the “[A26A1 DRAM and A26A2 Flash Boards](#)” replacement procedure.
2. Slide the CPU assembly into the deck. Keep the assembly flat as you slide it into the deck to avoid damage. Use caution not to pop off the plastic stand-offs on the bottom of the board. Fully engage the connectors by pushing on the CPU dress panel.
3. Refer to [Figure 11-48](#). Using the T-10 driver, secure the assembly to the rear frame with the 14 screws (1). Torque to 9 inch pounds.
4. Replace the A6 SCSI board. Refer to the “[A6 SCSI Board](#)” replacement procedure.
5. Replace the A7 Digital IF assembly. Refer to the “[Vertical Board Assemblies \(Standard Instrument\)](#)” replacement procedure.
6. Replace the instrument top brace. Refer to the “[Top Brace](#)” replacement procedure.

## Battery Replacement

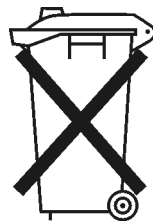
The battery is easily replaced by unclipping it from the board. Take care to install the new battery correctly to ensure proper polarity.

---

### WARNING

**Danger of explosion if battery is incorrectly replaced. Replace only with the same or equivalent type recommended. Discard used batteries according to manufacturer’s instructions.**

---



DO NOT THROW BATTERIES AWAY BUT  
COLLECT AS SMALL CHEMICAL WASTE.

---

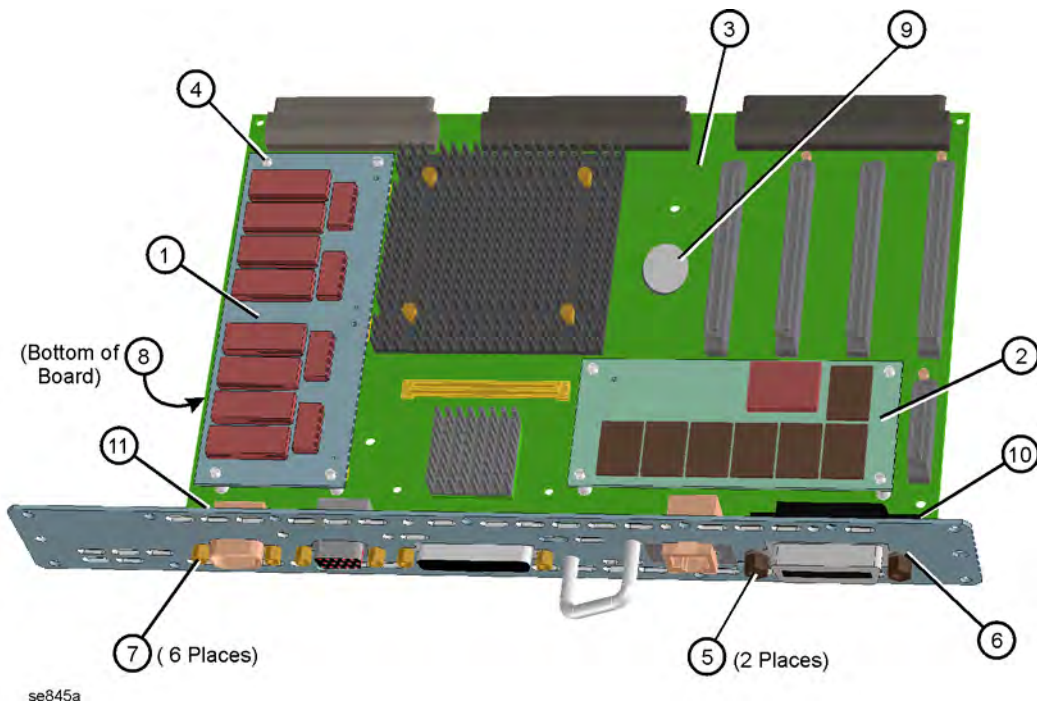
## A26A1 DRAM and A26A2 Flash Boards

**CAUTION** Use ESD precautions when performing this replacement procedure.

### Removal

1. Remove the instrument top brace. Refer to the “[Top Brace](#)” removal procedure.
2. Remove the A26 assembly. Refer to the “[A26 CPU Assembly](#)” removal procedure.
3. Refer to [Figure 11-50](#). Cut the standoffs flush with the top of the memory board, and carefully pull up on either the A26A1 DRAM board (1), or the A26A2 Flash board (2) to disengage it from the CPU assembly.

**Figure 11-50** A26A1 and A26A2 Board Removal



## Replacement

---

**NOTE**

---

Replacement DRAM and Flash boards are packaged with replacement standoffs.

1. Install the new standoffs.
2. To replace the DRAM or Flash boards, align the connectors and pins of the board over the holes and press down to seat the board.
3. Replace the A26 assembly. Refer to the [“A26 CPU Assembly”](#) replacement procedure.
4. Replace the instrument top brace. Refer to the [“Top Brace”](#) replacement procedure.

## Rear Frame

---

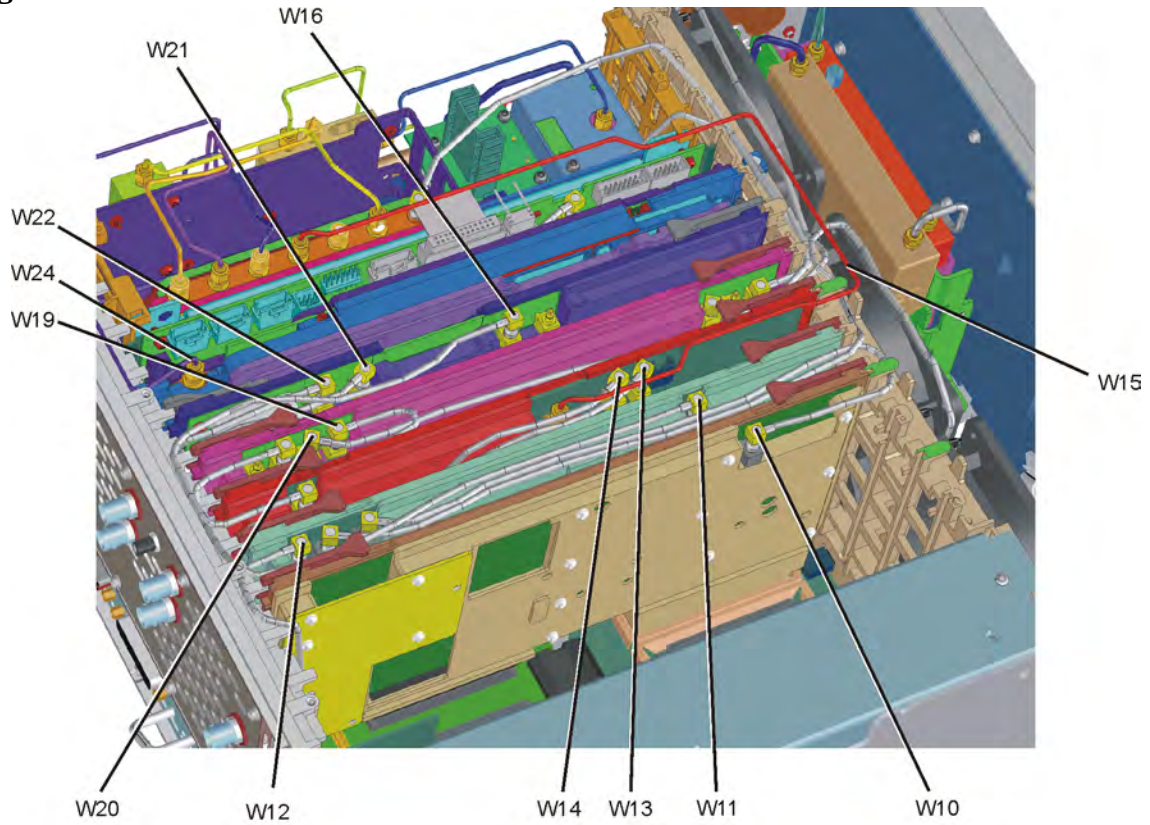
**CAUTION**

Use ESD precautions when performing this replacement procedure.

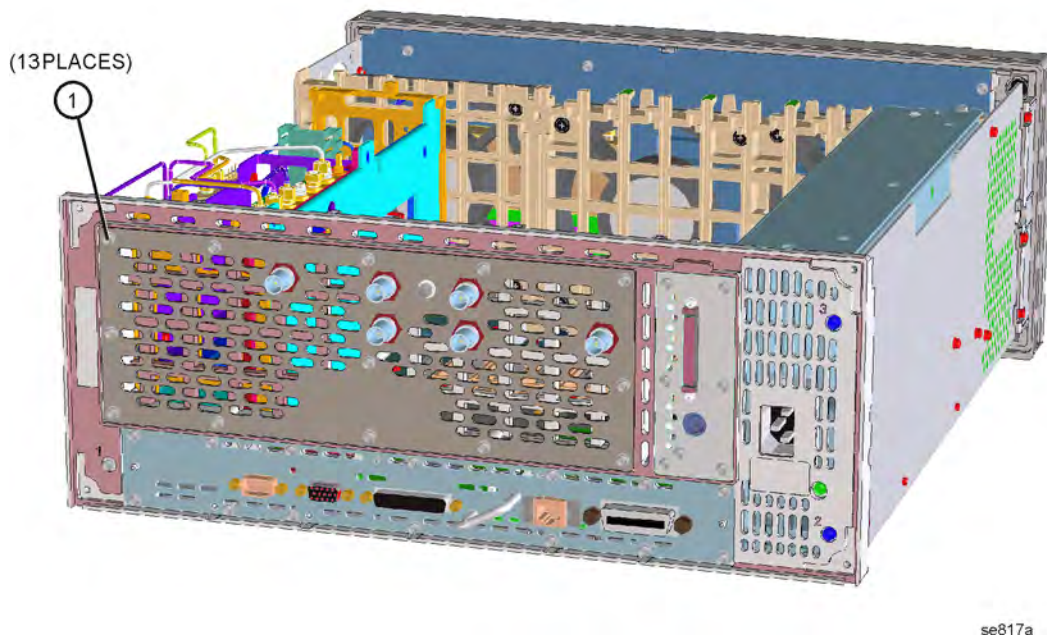
### Removal

1. Remove the instrument top brace. Refer to the “[Top Brace](#)” removal procedure.
2. Refer to [Figure 11-51](#). Unplug the W12, W13, W14, W19, W21, and W22 cables from the boards. If the instrument has optional hardware, there will be additional cables to remove.
3. Remove the vertical board assemblies. Refer to the “[Vertical Board Assemblies \(Standard Instrument\)](#)” removal procedure.
4. Remove the A6 SCSI board. Refer to the “[A6 SCSI Board](#)” removal procedure.
5. Remove the A26 CPU assembly. Refer to the “[A26 CPU Assembly](#)” removal procedure.
6. Refer to [Figure 11-52](#). Remove the rear dress panel, which includes numerous cables. Using the T-10 driver, remove the 13 screws (1).
7. Refer to [Figure 11-53](#). Using a T-10 driver, remove the 11 screws (1) that secure the rear frame to the deck. Remove the rear frame from the deck.

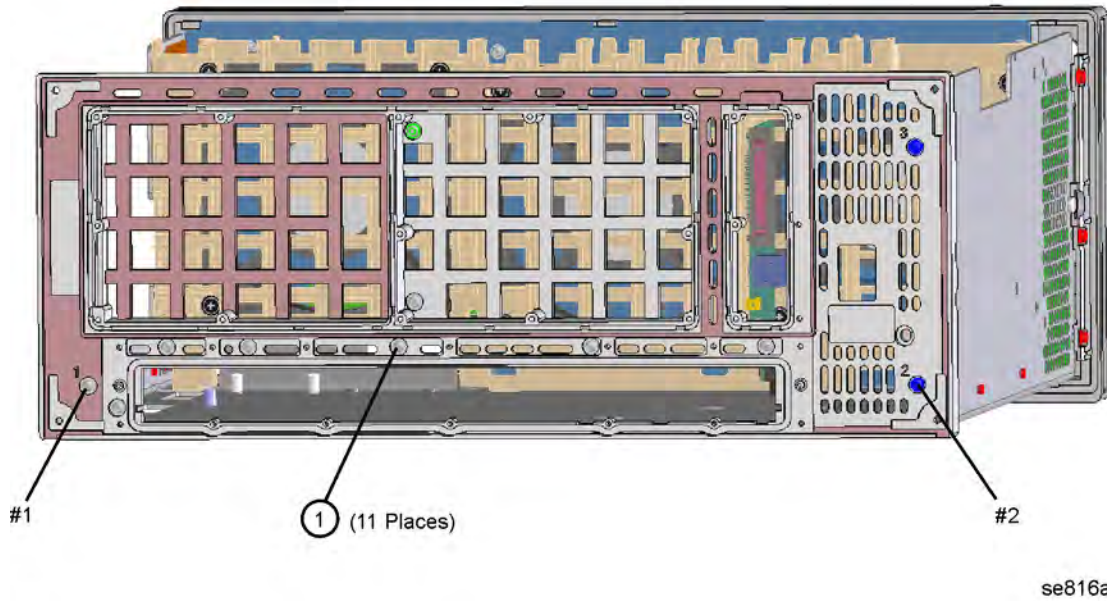
**Figure 11-51 Rear Panel Cables**



**Figure 11-52 Rear Dress Panel Removal**



**Figure 11-53 Rear Frame Removal**



## Replacement

1. Place the rear frame in position on the deck.
2. Using the T-10 driver, replace the 11 screws to secure the rear frame to the deck. For alignment purposes, tighten the screws marked with a #1 and a #2 in [Figure 11-53](#). Torque to 9 inch pounds.
3. Replace the rear dress panel and reroute the cables. Refer to [Figure 11-51](#) to reconnect the cables to the correct locations.
4. Using the T-10 driver, replace the 13 screws that secure the dress panel to the rear frame. For alignment purposes, tighten the screws marked with a #1 and a #2 (silkscreened on the dress panel) first. Torque to 9 inch pounds.
5. Replace the A26 CPU assembly. Refer to the “[A26 CPU Assembly](#)” replacement procedure.
6. Replace the A6 SCSI board. Refer to the “[A6 SCSI Board](#)” replacement procedure.
7. Replace the vertical board assemblies and reattach the cables. Refer to the “[Vertical Board Assemblies \(Standard Instrument\)](#)” replacement procedure. Refer to [Figure 11-51](#) for the proper dressing of the cables.
8. Replace the instrument top brace. Refer to the “[Top Brace](#)” replacement procedure.



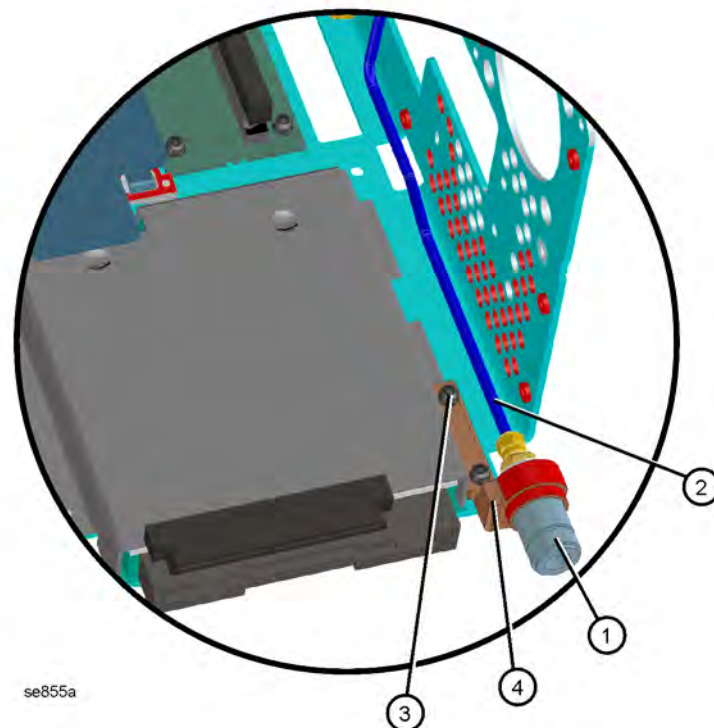
---

## RF Input Connector

### Removal

1. Remove the instrument outer case. Refer to the “[Instrument Outer Case](#)” removal procedure.
2. Remove the instrument top brace. Refer to the “[Top Brace](#)” removal procedure.
3. Remove the front frame. Refer to the “[Front Frame](#)” removal procedure.
4. Refer to [Figure 11-54](#). Using a 5/16 inch wrench, disconnect the semi-rigid cable (2) from the connector.
5. Using the T-10 driver, remove the 2 screws (3) that secure the input connector bracket to the deck.
6. Remove the connector and bracket from the instrument.
7. Remove the connector from the bracket (4) using a 9/16 inch wrench.

**Figure 11-54** RF Input Connector



## Replacement

1. Attach the new connector to the bracket. Torque to 80 inch pounds.
2. Replace the connector and bracket into the instrument.
3. Using the T-10 driver, replace the 2 screws that secure the input connector bracket to the deck. Torque to 9 inch pounds.
4. Using a 5/16 inch wrench, reconnect the semi-rigid cable to the connector. To avoid twisting the cable, hold onto it during tightening. Torque to 10 inch pounds.
5. Replace the front frame. Refer to the “[Front Frame](#)” replacement procedure.
6. Replace the instrument top brace. Refer to the “[Top Brace](#)” replacement procedure.
7. Replace the instrument outer case. Refer to the “[Instrument Outer Case](#)” removal procedure.

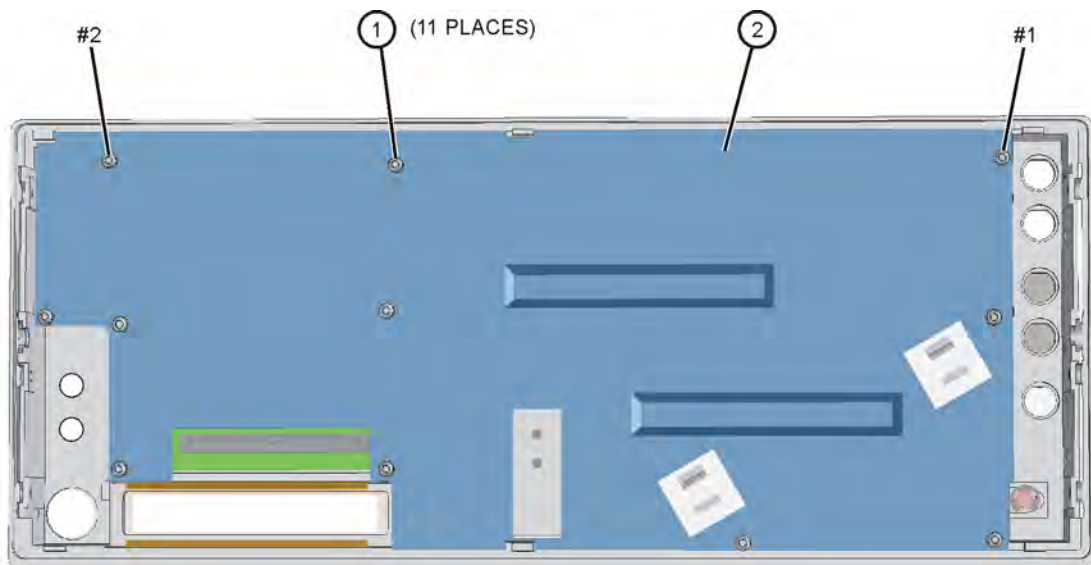
## Front Frame Subassemblies

In order to remove any of the following subassemblies, it is necessary to drop the front frame assembly from the main deck. Refer to the “[Drop the Front Frame](#)” procedure. It will also be necessary to remove the front shield from the front frame assembly. Refer to [Figure 11-55](#). Remove the cables from the cable clamps. Using the T-10 driver, remove the 11 screws (1) securing the front shield (2) to the front frame. Lift the shield from the front frame.

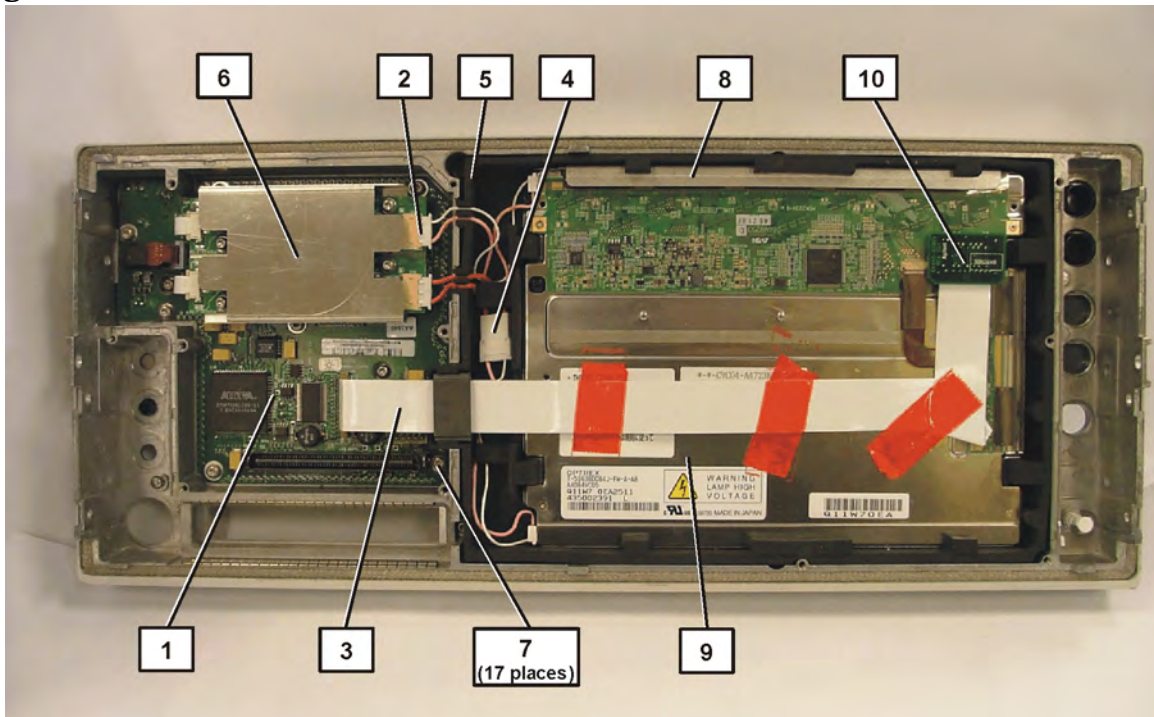
After the subassembly is changed, replace the front shield using the 11 screws removed earlier. For alignment purposes, tighten the screws marked with #1 and #2 first (silkscreened on the shield), then tighten the remaining screws. Torque to 9 inch pounds. Reconnect the front frame to the deck. Refer to the “[Front Frame](#)” replacement procedure.

**CAUTION** Use ESD precautions when performing the following replacement procedures.

**Figure 11-55 Front Frame Shield**



**Figure 11-56 Front Frame Subassemblies**

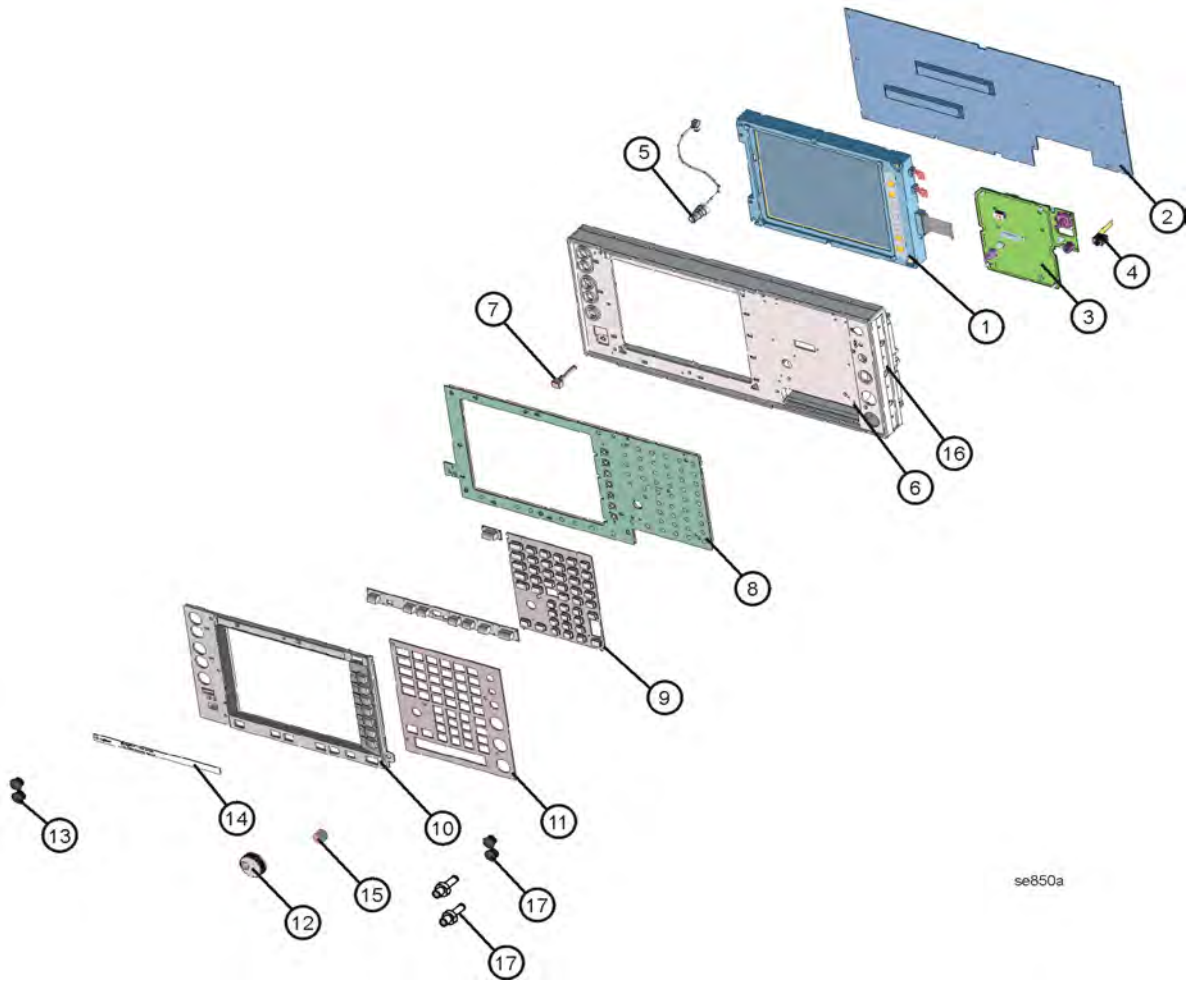


The front frame assembly consists of the following sub-assemblies:

- Front Panel Interface Board (1)
- Inverter Boards (2)
- W5 Flat Flex cable (3)
- Backlight extension cable (4)
- Display Mount (5)
- Inverter Shield (6)
- Pressure Plate(8)
- Flat Panel Display (9)
- Display Converter Board (10)

## Front Frame Exploded View

**Figure 11-57** Front Frame Exploded View

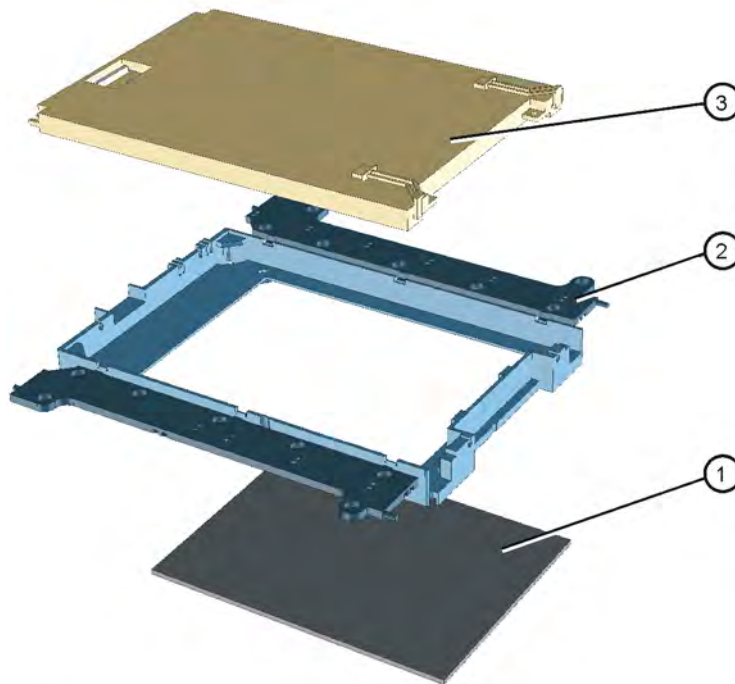


se850a

Item	Description	Item	Description
1	Display Assembly	9	Keypad
2	Front Shield	10	Display Bezel Assembly
3	A2 Front Panel Interface Assembly	11	Dress Panel Assembly
4	A28 Audio Out Board	12	RPG Knob
5	W1 Ext Trigger Input Cable	13	Hole Plug, Nylon
6	Front Frame Assembly	14	Name Plate overlay label
7	Line Key (push rod)	15	Volume Knob
8	A3 Keyboard	16	Side Trim
		17	Hole plugs or SMA adapters (Option AYZ)

## A1 Display and Filter

**Figure 11-58**      **Display Parts**



The display assembly consists of:

- EMI filter (1)
- display mount (2)
- flat panel display (3)

## Display Removal

---

**CAUTION**

Work in a clean environment to avoid getting dust on the display. The new flat panel display comes with a protective plastic sheet over the glass. Remove this plastic very slowly to avoid damage due to ESD.

---

---

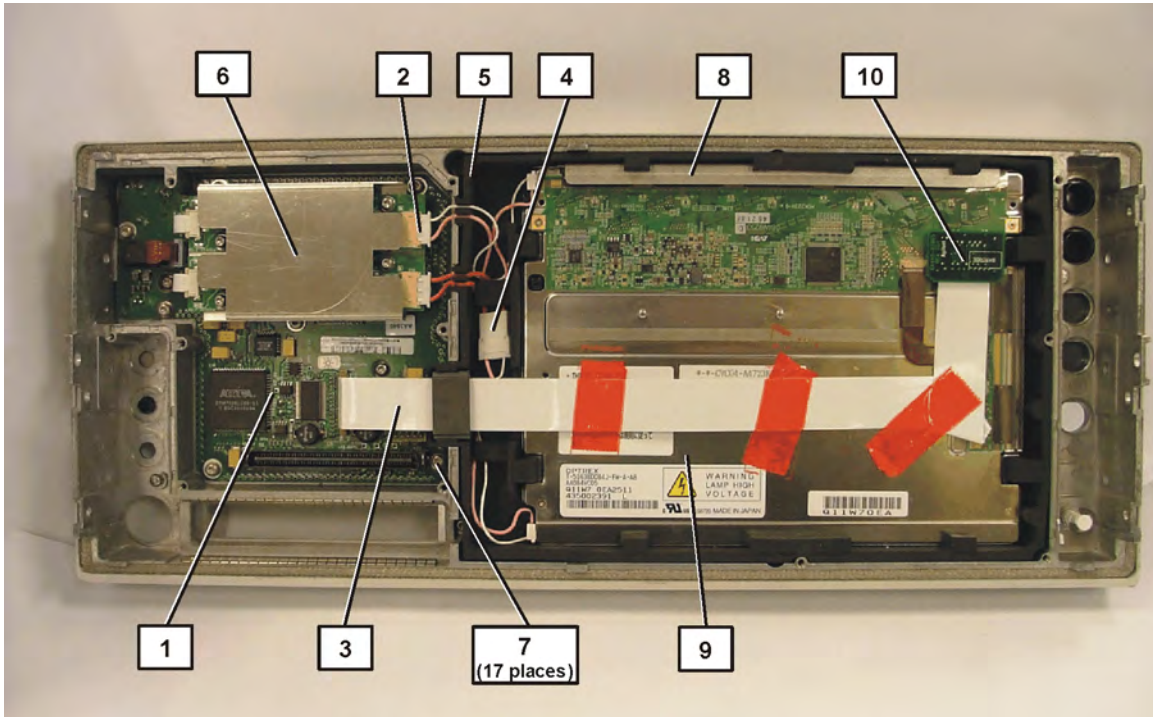
**CAUTION**

The surface of the display is very easily scratched. Avoid touching it with your bare hands or other objects. Use a blower to remove any dust from the display surface.

---

1. Refer to [Figure 11-59](#). Unplug the Display Converter Board (10) from the Flat Panel Display. Peel back the attached flat flex cable (3) with the tape still attached until the ferrite block is free of the rubber mount.
2. Unplug the inverter backlight cable from the top inverter board and pull cable free of the rubber display mount (5).
3. Unplug the bottom backlight cable at the backlight extension cable (4) and pull the backlight extension cable free of the rubber display mount.
4. Remove the display mount / display from the front frame.
5. Remove the pressure plate (8) from between the display mount at the top of the display.
6. Peel back the rubber tabs on the display mount and carefully remove the display.

**Figure 11-59**      **Front Frame Subassemblies**



### Display Replacement

1. Carefully place the display into the rubber display mount. Flex the display mount rubber tabs until they are in place over the edges of the display.
2. Refer to [Figure 11-59](#). Install the pressure plate (8) between the display mount and the top of the display.
3. Place the display mount / display into the front frame.
4. Route the bottom display backlight cable from the display under the rubber tab of the display mount.
5. Plug the bottom backlight cable from the display into the backlight extension cable (4). Press the backlight extension cable into the grooves of the display mount.
6. Plug the top backlight cable from the display into the top inverter board. Press the backlight extension cable into the grooves of the display mount.
7. Plug the Display Converter board/flat flex cable into the flat panel display connector.
8. Place the ferrite block (on the flat flex cable) into the rubber display mount.
9. Press the tape down on the flat flex cable to secure the cable to the display.



### Display Filter Removal/Replacement

1. Remove the rubber mount containing the display assembly from the front frame. Refer to the “[Display Removal](#)” procedure on [page 399](#).

---

**CAUTION**

Be careful when handling the display/mount assembly outside of the front frame. The individual components are not secured in the mount and could possibly fall out of the mount unless it is held together.

---

2. Flip the display/mount assembly over and place it filter-side up on a flat surface.
3. The display filter can now be removed by pulling back on one of the corner supports (2) and lifting the filter (1) out of the mount as shown in [Figure 11-60](#).
4. When you install a new filter, take care to touch only the outside edges. Install the filter into the mount by sliding under the corner supports.

---

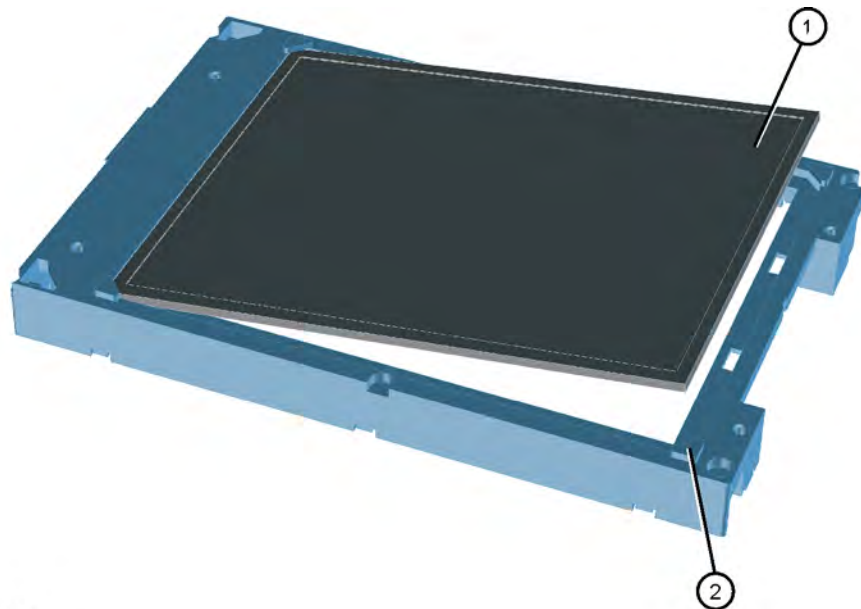
**NOTE**

Make sure the side of the filter with the silver edge is facing up, away from the display.

---

5. The display/mount assembly can now be reinstalled into the front frame. Refer to the “[Display Replacement](#)” procedure on [page 400](#).

**Figure 11-60** Display Filter Replacement



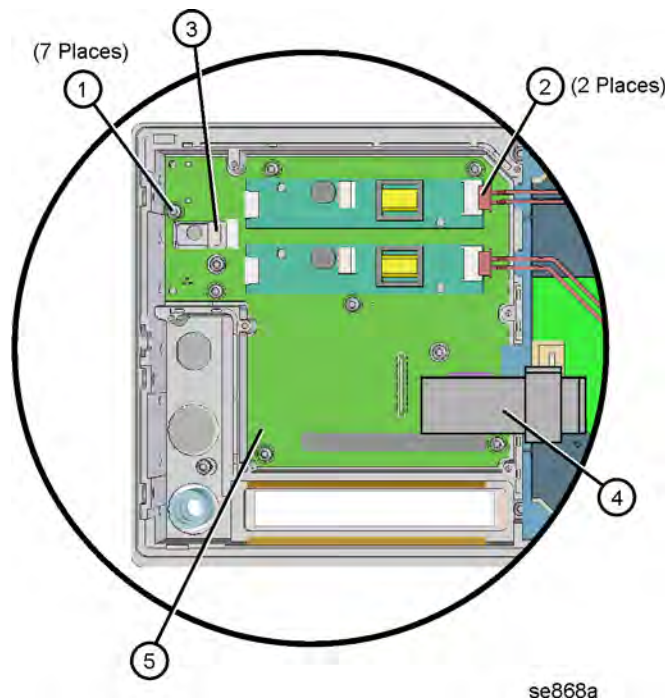
se844a

## A2 Front Panel Interface Board

### Removal

1. Remove the RPG knob and volume knob by pulling straight off of the control shafts.
2. Refer to [Figure 11-61](#). Unplug both of the 2-wire backlight cables (2) from the inverter boards.
3. Unplug the Audio Out (3) cable from the interface board.
4. Unplug the display flat flex cable (4) from the front panel interface board. To do this, you must first pull up on both sides of the locking mechanism of the ribbon cable connector.
5. Using the T-10 driver, remove the 7 screws (1) that secure the front panel interface board (5) to the front frame assembly.
6. Lift the front panel interface board from the front frame assembly.

**Figure 11-61** A2 Front Panel Interface Board Removal



## **Replacement**

1. Place the front panel interface board into position in the front frame assembly. Mate the connector with the connector in the keyboard.
2. Using the T-10 driver, replace the 7 screws that secure the board to the front frame. Torque to 9 inch pounds.
3. Plug the display flat flex cable into the front panel interface board connector. Push down on both sides of the locking mechanism.
4. Reconnect the Audio Out cable.
5. Reconnect both of the 2-wire backlight cables.
6. Press the RPG knob and volume knob onto the control shafts.

## Bezel and Keypad

### Removal

1. Remove the display/rubber mount assembly. Refer to the first section of the “[Display Removal](#)” procedure.
2. Remove the RPG knob and volume knob by pulling straight off of the control shafts.
3. Refer to [Figure 11-62](#). Using the T-10 driver, remove the 10 screws (1) that secure the bezel and keyboard assembly to the front frame.
4. Refer to [Figure 11-63](#). The 10 screws also attach the dress panel, bezel, subpanel, keypad, and keyboard to the front frame. Take care to keep these parts in the correct order and aligned properly.
5. Lift the front frame off of the keypad/keyboard assembly.
6. The bezel and keyboard can now be separated by pressing on the pin just above the **On/Standby** LEDs on the bezel and sliding apart to unlock the tabs. The flexible keypads can be separated from the keyboard and the bezel by pulling them apart.

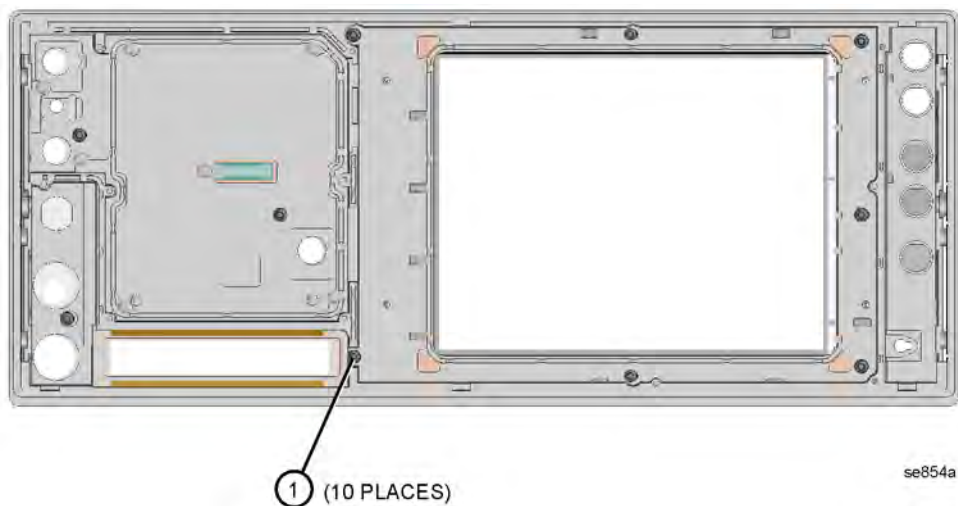
---

**NOTE**

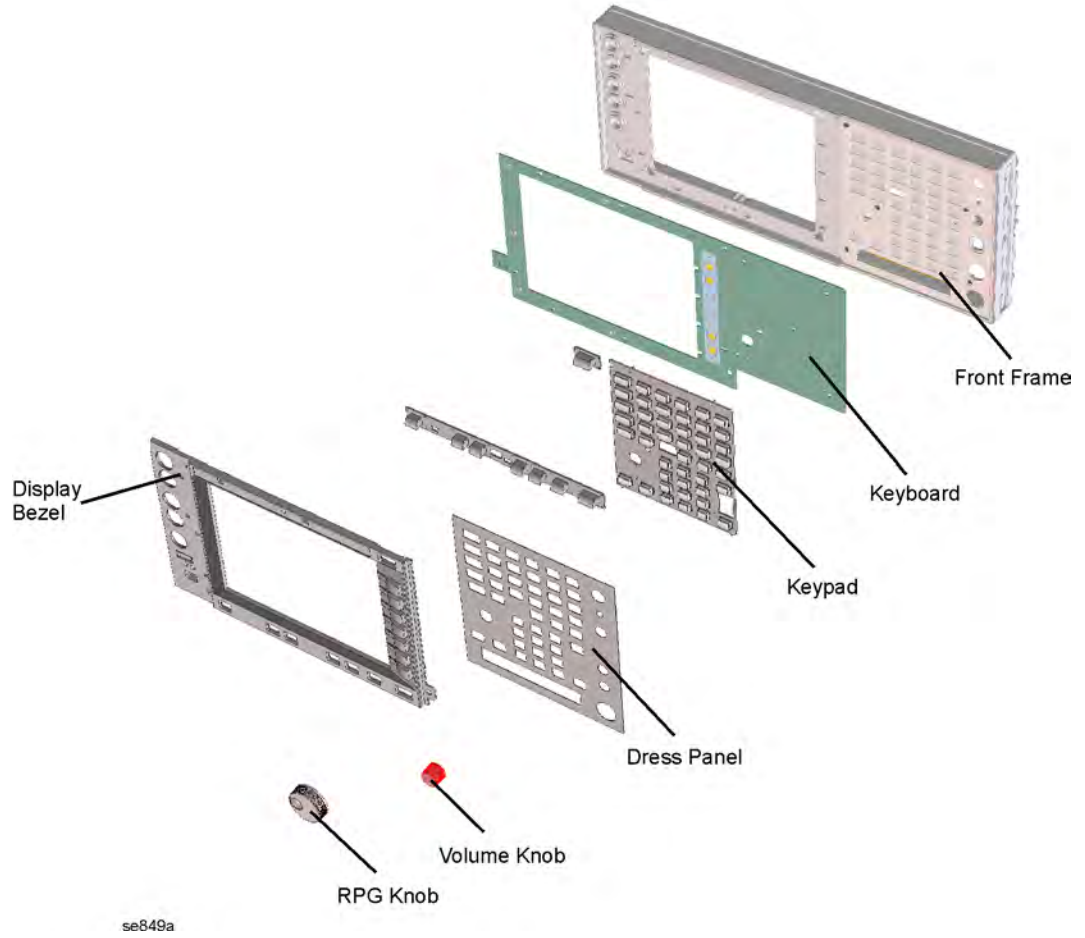
Take care to not touch the contacts on the keypads. Contaminants on the contacts might interfere with the performance of the key.

---

**Figure 11-62**     **Keypad Removal**



**Figure 11-63 Keypad Parts**



## Replacement

1. Place the keypad into position in the bezel. Press on the keypad to engage the alignment pins and to seat the keys.
2. Place the keyboard over the bezel alignment pins and carefully slide to lock into place.
3. Refer to [Figure 11-63](#). Place the keyboard/bezel assembly face down on top of the dress panel and subpanel on a flat surface. Install the front frame over the keyboard/bezel assembly. Using the T-10 driver, replace the 10 screws (1) that secure the bezel and keypad to the front frame. Torque to 9 inch pounds.
4. Press the RPG knob and volume knob onto the control shafts.
5. Replace the display/rubber mount assembly. Refer to the last section of the [“Display Replacement”](#) procedure.

## RPG

### Removal/Replacement

1. Remove the front panel interface board. Refer to the “[A2 Front Panel Interface Board](#)” removal procedure.
2. Unsolder the RPG, remove the nut and washer, and remove it from the front panel interface board.
3. Place the new RPG in the correct position, tighten the nut and washer, and resolder the leads.
4. Replace the front panel interface board. Refer to the “[A2 Front Panel Interface Board](#)” replacement procedure.

## External Trigger Cable

### Removal/Replacement

---

**NOTE**

---

The front panel External Trigger connector/cable must be replaced as an assembly.

---

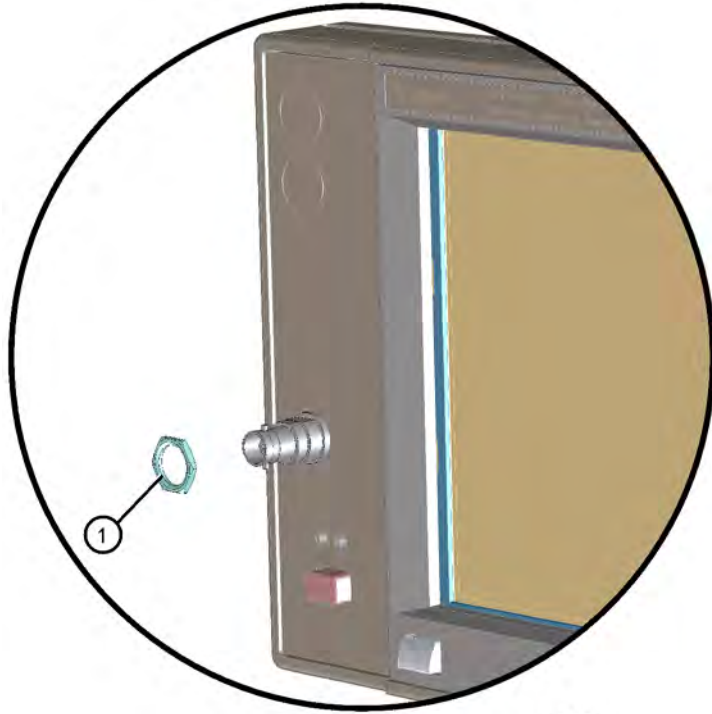
**CAUTION**

---

Be careful to not scratch the dress panel when removing or replacing this part.

1. Remove the front frame assembly. Refer to the “[Front Frame](#)” removal procedure on [page 314](#).
2. Refer to [Figure 11-64](#). Using the 9/16 socket, remove the nut (1) that secures the connector to the front frame.
3. Disconnect the cable from the A8 analog IF assembly.
4. For replacement, position the connector/cable through the front frame, matching the “D” slot.
5. Using the 9/16 socket, replace the nut to secure the connector to the front frame. Torque to 21 inch pounds.
6. Clip the cable into the cable clamps on the shield.
7. Re-route the cable to avoid interference with the fans or the airflow, and reconnect to the A8 analog IF assembly.
8. Replace the front frame. Refer to the “[Front Frame](#)” replacement procedure.

**Figure 11-64** Front Panel External Trigger Input Connector Removal



se842a





## What You Will Find in This Chapter

This chapter provides information that will enable you to return an instrument to full operation following the replacement of any instrument assembly. This information includes the following:

- ❑ A table that shows which adjustments, tests, and configurations must be executed after replacing an assembly.
- ❑ Procedures for configuring a replacement CPU assembly and a Flash memory assembly.
- ❑ A procedure for checking the burst trigger.
- ❑ A test that confirms the functionality of the instrument front panel.

The following sections are located in this chapter:

- Before Starting ..... [page 411](#)
- Post-Repair Procedures Table ..... [page 412](#)
- Configuring a Replacement CPU Assembly ..... [page 422](#)
- Configuring a Replacement Flash Memory Assembly ..... [page 425](#)

To determine which Performance Verification/Adjustment Software tests to perform, refer to [Table 12-1](#) in this chapter.

---

**NOTE** If one or more instrument assemblies has been replaced, related adjustment or configuration procedures **must** be performed prior to verifying that the instrument meets specifications. Refer to [Table 12-1](#) to determine which procedures to perform after replacing an assembly.

---

**NOTE** Never perform adjustments as routine maintenance. Adjustments should only be performed after a repair or a performance test failure.

---

**NOTE** If the indications received during a procedure execution do not agree with the normal conditions given in the procedure, a fault exists in your instrument. The fault should be repaired *before* proceeding with any further procedures. Refer to the troubleshooting and repair information in [Chapter 2](#) of this guide.

---

## Before Starting

There are four things you should do before starting any of the procedures listed or described in this chapter:

- ❑ Familiarize yourself with the safety symbols marked on the unit under test (UUT), and read the general safety considerations and the safety note definitions in the front of this guide, **before** you begin the procedures in this chapter.
- ❑ Check that the UUT has been turned on and allowed to warm up.
- ❑ Ensure that the UUT is operating within a temperature range of 20 °C to 30 °C.
- ❑ Read the rest of this section.

### Test equipment you will need

Refer to [Table 1-3 on page 24](#), for a list of recommended equipment and critical test equipment specifications for the performance verification and adjustments.

## Post-Repair Procedures

Table 12-1 lists the adjustments, configuration or calibration constant reset procedures, and performance verification tests needed after an assembly replacement. Adjustments and performance verification tests and the utility that resets the calibration constants and resets the statistical data are located in the Performance Verification and Adjustment Software.

Calibration constants are stored on most board assemblies. Several PSA model numbers share the same board assembly, but require different calibration constants.

After an assembly is replaced, find the assembly that has been replaced in the left-hand column, and then perform the adjustment, test, or configuration procedure shown in the adjustment column. After successfully completing the necessary adjustment, test, or configuration procedure, verify that the instrument meets specifications by running the performance verification test or tests listed.

**NOTE** Refer to your user’s guide for information on instrument warm-up before performing any of the procedures listed in this chapter.

**Table 12-1 Post-Repair Testing Requirements**

Assembly	Adjustments, Tests, & Configuration	Performance Verification
A1 Flat Panel Display	Ensure that the display quality is satisfactory. There should be no light or dark lines or pixel “triplets”.	None
A2 Front Panel Interface Assembly	Perform the Internal Front Panel test. Press <b>System, More, Diagnostics</b> .  Ensure that the display quality and brightness are satisfactory.  Ensure that the green “power on” and yellow ‘standby’ LEDs function properly.	None
A3 Keyboard Assembly	Internal Front Panel test	None
A5 Power Supply	Verify that the instrument powers up correctly.  Check all power supply voltages using an extender board.	None
A6 SCSI Board	None	None

**Table 12-1 Post-Repair Testing Requirements (Continued)**

Assembly	Adjustments, Tests, & Configuration	Performance Verification
A7 Digital IF Assembly	Internal Align All Now Perform the calibration constant reset procedure for this assembly	Absolute Amplitude Accuracy Resolution BW Switching Display Scale Fidelity Power BW Accuracy
A8 Analog IF Assembly	Perform the calibration constant reset procedure for this assembly Analog IF Input Detector adjustment Internal Align All Now Check function of the front panel external trigger input. Burst Trigger test on <a href="#">page 419</a>	Absolute Amplitude Accuracy Noise Sidebands < 50kHz Offset Power Bandwidth Accuracy Displayed Average Noise Level IF Amplitude Ripple (option B7J) Display Scale Fidelity IF Phase Ripple (option B7J) Resolution Bandwidth Switching Uncertainty
A9 2 <sup>nd</sup> LO/Fan Control Assembly	Second LO Power adjustment Check functionality of Trig 1 and Trig 2 rear panel outputs Check fan operation Assure there are no 2 <sup>nd</sup> LO unlock messages	Noise Sidebands (both tests)
A10 3 <sup>rd</sup> Converter Assembly	— E4440-60208 requires FW revision A.02.04 or greater — E4440-60213 requires FW revision A.03.03 or greater Perform the calibration constant reset procedure for this assembly 50 MHz Calibrator Amplitude adjustment Frequency Response adjustment, all bands IF Input Adjustment (Option AYZ)	Third Order Intermodulation Distortion Spurious Responses Absolute Amplitude Accuracy Displayed Average Noise Level Power Bandwidth Accuracy Frequency Response (all frequencies)

**Table 12-1 Post-Repair Testing Requirements (Continued)**

Assembly	Adjustments, Tests, & Configuration	Performance Verification
A11 Reference Assembly	Internal 10 MHz Frequency Reference adjustment	Noise Sidebands (both tests) Frequency Readout Accuracy Frequency Reference Accuracy
A12A1 LO/Synthesizer Board or A12 Assembly	Perform the calibration constant reset procedure for this assembly Requires FW revision A.04.08 or greater	Noise Sidebands (both tests) Frequency Span Accuracy
A12A2 Sample Oscillator Board	None	Noise Sidebands (both tests) Frequency Span Accuracy
A13 Front End Driver Board	Perform the calibration constant reset procedure for this assembly (E4446A, E4447A, E4448A only) Second LO Power adjustment Lowband Mixer Bias adjustment FELOMA adjustment or SLODA adjustment YTF Alignment Overload Detector DAC adjustment Attenuator Slope adjustment Frequency Response adjustment Preselector Tune Out adjustment (Option AYZ) 28 V Rear Panel Output Check Requires FW revision A.04.08 or greater	Absolute Amplitude Accuracy Frequency Response (all frequencies)

**Table 12-1 Post-Repair Testing Requirements (Continued)**

Assembly	Adjustments, Tests, & Configuration	Performance Verification
A14 Attenuator/Switch	50 MHz Calibrator Amplitude Attenuator Slope adjustment Frequency Response adjustment (all bands) Reset AC/DC switch activations (E4440A, E4443A, E4445A only) Reset attenuator activations and 50 MHz switch activations using software utility	Absolute Amplitude Accuracy Frequency Response (all frequencies) Input Attenuation Switching Uncertainty
A15 Attenuator, 66 dB	50 MHz Calibrator Amplitude Attenuator Slope adjustment Frequency Response adjustment (all bands) Reset attenuator activations and 50 MHz switch activations using software utility	Absolute Amplitude Accuracy Frequency Response (all frequencies) Input Attenuation Switching Uncertainty
A18 YTO	Assure that 1 <sup>st</sup> LO Unleveled message does not appear	Absolute Amplitude Accuracy Frequency Response (all frequencies) Noise Sidebands (both tests) Residual Responses
A19 RYTHM or SBTX/RYTHM	SLODA or FELOMA adjustment YTF Alignment Attenuator Slope adjustment Frequency Response adjustment (all bands)	Frequency Response (all frequencies) Displayed Average Noise Level Absolute Amplitude Accuracy Residual Responses

**Table 12-1 Post-Repair Testing Requirements (Continued)**

Assembly	Adjustments, Tests, & Configuration	Performance Verification
A20 Lowband Assembly	2 <sup>nd</sup> LO Power adjustment Lowband Mixer Bias adjustment Overload Detector DAC adjustment Frequency Response adjustment	Gain Compression Displayed Average Noise Level Second Harmonic Distortion TOI Absolute Amplitude Accuracy Frequency Response Below 300 kHz Frequency Response 300 kHz to 3 GHz
A21 SLODA or FELOMA	SLODA adjustment or FELOMA adjustment LO Output adjustment (Option AYZ) SLODA adjustment (Option 123)	Absolute Amplitude Accuracy Frequency Response (all frequencies)
A22 Preamp, (Option 1DS)	Frequency Response adjustment Reset Preamp switch activations using software utility Requires FW revision A.06.04 or greater	Absolute Amplitude Accuracy Displayed Average Noise Level Frequency Response Below 300 kHz Frequency Response 300 kHz to 3 GHz
A23 Disk Drive	Save data to a disk	None
A25 Mother Board		All tests, since entire instrument was taken apart.
A26 CPU (processor) Assembly	Perform <a href="#">Configuring a Replacement CPU Assembly</a> on page 422	None
A26A1 DRAM Board	None	None
A26A2 Flash Memory Board	Perform <a href="#">Configuring a Replacement Flash Memory Assembly</a> on page 425	None
A27 Electronic Attenuator	Frequency Response (B7J) adjustment	Absolute Amplitude Accuracy Frequency Response 300 kHz to 3 GHz



**Table 12-1 Post-Repair Testing Requirements (Continued)**

Assembly	Adjustments, Tests, & Configuration	Performance Verification
A29 FELOMA/SBTX Driver	FELOMA adjustment YTF adjustment Frequency Response adjustment	Absolute Amplitude Accuracy Frequency Response Above 3 GHz
A30 First IF Amplifier (FIFA)	Frequency Response adjustment	Absolute Amplitude Accuracy Frequency Response Above 3 GHz
A31 Wideband Analog IF Assembly (Option 122 or 140)	Perform WB IF Cal Constant Reset Perform IF Frequency Response (Wide IF)	Absolute Amplitude Accuracy Third Order Intermodulation Distortion (Wide IF) Spurious Response Input Noise Density (Wide IF) IF Frequency Response (Wide IF) Residual Responses Noise Sidebands < 50kHz Noise Sidebands > 50kHz
A32 Wideband Digital IF Assembly (Option 122 or 140)	Load the latest instrument firmware to assure instrument and Digital IF firmware are compatible.	None
A34 Dual Mixer (Option 123)	Dual Mixer Bias adjustment Frequency Response adjustment (Option 123)	Frequency Response (Option 123) Displayed Average Noise Level
A34 Unpreselected Mixer (E4446A, E4447A, E4448A)	Millimeter Unpreselected Mixer Bias adjustment Frequency Response adjustment (Option 123)	Displayed Average Noise Level Frequency Response above 3 GHz Frequency Response (Option 123)

**Table 12-1 Post-Repair Testing Requirements (Continued)**

Assembly	Adjustments, Tests, & Configuration	Performance Verification
A35 Unpreselected Mixer Bias Board	Millimeter Unpreselected Mixer Bias adjustment  Frequency Response adjustment above 3 GHz (Option 110/123)	Displayed Average Noise Level  Frequency Response above 3 GHz
A36 Microwave or Millimeter Wave Preamp	Frequency Response adjustment less than 3 GHz  Frequency Response adjustment above 3 GHz (Option 110)	Absolute Amplitude Accuracy  Residual Responses  Displayed Average Noise Level  Frequency Response 300 kHz to 3 GHz  Frequency Response above 3 GHz
A37 Audio Assembly	Audio Step Gain and Calibrator adjustment  Audio Flatness adjustment	Audio Distortion  Audio Amplitude Accuracy
A38 Option Driver Assembly	Millimeter Unpreselected Mixer Bias adjustment (if Option 123 installed, E4446, 47, 48)  Frequency Response adjustment (Option 110/123)	Displayed Average Noise Level  Frequency Response (Option 110)  Frequency Response (Option 123)
A39 USB/Flash Assembly	Load latest firmware	None
SW1, SW2, SW3 (Option 123)	Frequency Response adjustment (Option 123)	Frequency Response (Option 123)  Displayed Average Noise Level
SW4, SW5		Displayed Average Noise Level  Frequency Response above 3 GHz
J1 Input connector	Depends on result of frequency response performance test.	Absolute Amplitude Accuracy  Frequency Response (all frequencies)

## Burst Trigger Check

### Description

The Burst Trigger Check verifies the ability of the instrument to sync on the burst trigger signal. The instrument internal IF Alignment signal is activated and configured to provide a pulse train. The pulses are displayed on the RF Envelope window, and will appear as an unsynchronized signal. When the RF Burst trigger function is activated, the RF train will sync on the burst trigger signal.

### Procedure

1. Press **Reset**.
2. Press **MODE** and **Basic**.
3. Press **Input/Output**.
4. Press **Input Port, IF Align**.
5. Press **IF Align Signal**.
6. Press **Signal Type** and choose Pulse.
7. Notice that the I/Q waveform window shows an untriggered display.
8. Press **Meas Setup, Trig Source**, and **RF Burst**. The pulse train, displayed on the I/Q waveform window, will now be synchronized.

## Internal Front Panel Test

### Description

The Front Panel Test allows key presses and RPG knob rotations to be displayed on the instrument's screen. This diagnosis is useful when checking the functionality of all keys and the RPG knob.

Press: **System, More, Diagnostics, Front Panel Test**

## 28 V Rear Panel Output Check

### Description

Instruments with Option 219 and instruments with Front End Driver assemblies E4440-60242 (<27 GHz models) or E4446-60059 (> 27 GHz models) have a switchable 28 V connector on the rear panel.

Connect a voltmeter to the rear panel Noise Source Drive Out connector. To turn on and off the 28 V, press **System** then **Service**. Key in the password **-49**, and press **Enter**. Press **Service** then press the **Noise Source** key to toggle the 28 V on and off. The voltage should read 28 V  $\pm 0.2$  V.

## Configuring a Replacement CPU Assembly

### Description

When only the main CPU board is replaced, it is necessary to reconfigure it with certain data that is critical for instrument operation. This information includes the IP address, time, date, instrument serial number, and the host name. If possible, it is best to capture this information from the instrument before replacing the main CPU board.

---

**NOTE**

A PC and the PSA Series Spectrum Analyzers Test and Adjustment software is required to restore the serial number.

---

### Procedure

#### Capturing Critical Data for the CPU Board

Ensure that all information is recorded exactly as it is displayed.

1. To view the host name and IP address, press **System** and **Configure I/O**.

---

**NOTE**

The Ethernet Number is embedded in the CPU, and it will change when the CPU is replaced. When the Ethernet Address changes the Flash Memory board will reset the IP address and host name to the default factory values.

---

2. To view the instrument serial number, press **System, More** until (2 of 3) is displayed, and **Show System**. Refer to the note below before proceeding.
  - a. Confirm that the serial number on screen matches the number on the rear panel tag.
  - b. If the instrument is not functional, record the serial number on the rear panel tag.

---

**NOTE**

The serial number stored in memory is used to enable all licensed options. If the stored serial number is different from the rear panel serial number sticker, then the instrument has an incorrect CPU board installed or an incorrect serial number was entered into the CPU when it was last replaced. If the two serial numbers do not match, determine the cause and correct the problem.

If you cannot correct the problem, and you use the rear panel serial number on the new CPU board, the keywords associated with the stored serial number will no longer enable the options. In this case, contact Agilent Technologies sales and service office for the correct license numbers for your instrument. To contact the Agilent Technologies sales and service office, refer to [“Contacting Agilent Technologies” on page 37](#).

---

**Replacing the Processor Assembly**

There are two boards mounted on the main processor assembly (A26) board: the A26A1 DRAM board and the A26A2 Flash board. These boards must be removed from the defective CPU board and installed on the new CPU board.

The Flash memory board contains the operating system, main firmware, measurement personality firmware, license key words. The DRAM memory board can be costly to replace. Transferring the Flash memory board from the defective processor board will save time otherwise required to reconfigure. Transferring both boards will help keep repair cost low.

Remove the insulator between the battery and battery clip, or remove the battery from the new replacement CPU for 2 to 3 minutes. This will allow the new CPU to obtain data (such as the attenuator actuations) stored on other instrument assemblies.

Refer to assembly replacement procedure [“A26A1 DRAM and A26A2 Flash Boards” on page 388](#) for details on replacing the defective main processor board and transferring the two memory boards.

**Entering Configuration Information**

After the processor is replaced, restore power to the instrument and enter the necessary configuration information.

Confirm the instrument boots up. There may be some error messages, but they will go away when the instrument is booted a second time.

---

**CAUTION**

Because the serial number can not be removed once it is entered, ensure that the new processor board corrects the problem before continuing with this procedure.

---

### Entering the Serial Number

1. Load the PSA Series Spectrum Analyzers Test and Adjustment software on your PC.
2. Under Test Plan, select Utilities.
3. Under Available Tests, choose Serial Number Initialization.

---

**CAUTION**

You have only one chance to enter the serial number into the replacement processor memory. Ensure that the number you enter matches the number on the serial number tag on the rear panel. Use extreme care when typing the serial number.

---

4. Follow the prompts and enter the serial number.

### Entering the Time and Date

1. Press **System, Time/Date** and select the Date Format.
2. Press **Set Time**, and enter the time in the format hh.mm.ss. For example, 15.25.30 for 15 hours 25 minutes and 30 seconds. Press the **Enter** softkey.
3. Press **Set Date** and enter the date in the format yyymmdd. For example 20020311 for May 11, 2002. Press the **Enter** softkey.

### Entering the IP Address and Host Name

To enter the IP Address and Host Name, refer to [“Step 5: Entering the IP Address and Host Name”](#) on page 427.



## Configuring a Replacement Flash Memory Assembly

### Description

The Flash memory board contains the instrument operating system, the core firmware (firmware that tells the PSA how to do basic spectrum analysis), and possibly optional measurement personality firmware. The optional personality firmware is keyword protected, and the keywords are also stored in Flash memory. Also, Flash memory contains the IP address and instrument Host Name.

The replacement Flash board has been preloaded with the operating system and core instrument firmware only. Therefore, if your instrument contains optional measurement personalities, additional firmware will need to be loaded, and the license keywords installed.

The following procedure outlines how to perform the process of configuring a replacement Flash memory board

---

#### NOTE

Since the Flash memory does not contain calibration data, and the instrument will perform an auto align when powered up, instrument recalibration should not be required following this repair. The installation of the hardware should take about 1 hour to complete. Installation of optional measurement personalities and re-licensing varies with the number of options.

All user stored files such as instrument states or traces from the original Flash board will be lost.

---

#### WARNING

**The following procedure must be done at a static safe work area**

### Equipment Required

Microsoft Windows based Personal Computer with Local Area Network (LAN) card

Web access or a CD ROM with the latest instrument firmware

Printer compatible with the PSA. (optional)

## Procedure

### Step 1: Capture Configuration Information (if possible)

- a. If the instrument is able to boot and display the softkey menus, it should be possible to gather information using the following process. If the existing Flash board will not allow this, the configuration information will need to be obtained by other means described in the “Non-Functional Instrument” section at the end of this procedure.
- b. Power on the PSA.
- c. Connect a printer to the PSA. If no printer is available, you will need to carefully write down the options loaded, the license keywords for each option and the IP Address and GPIB address.
- d. On the PSA, press **System, More, Licensing, Show License** to display the list of loaded options and their associated option designators and license key numbers. Press the **Print** key on the PSA.
- e. On the PSA, press **System, More, Show System**. Under the Options heading, you can see the designators for the hardware and firmware options. Hardware options are 1DS (preamp), B7J (electronic attenuator) and BAB (APC 3.5 connector). Press the **Print** key on the PSA to print the entire screen, or write down the option designators.
- f. On the PSA, press **System, Config I/O**. Press the **Print** button on the PSA, or write down all information on the softkeys (the GPIB address, the IP Address, Subnet Mask, and Default Gateway).

### Step 2: Replacing the Flash Board

- a. Power down the PSA.
- b. Remove all cables attached to the rear panel of the PSA.
- c. Refer to assembly replacement procedure [“A26A1 DRAM and A26A2 Flash Boards” on page 388](#).

### Step 3: Enter Option License Keyword Numbers (if needed)

Using the printout of loaded options and their associated option designators and license key numbers, reinstall the options.

The option designation consists of three upper-case letters or numbers, as shown in the table below.

Option	Option Designation
Pre-amplifier	1DS
Phase Noise Measurement	226

- a. Press **System, More** until the **Licensing** softkey is visible. Press **Licensing** and **Option**. This will activate the alpha editor menu. Use the alpha editor to enter the upper case option designator. Press **Enter**.
- b. Press **License Key**. The license key number is a hexadecimal number that will require the entry of both letters and numbers. Use the alpha editor to enter the letters and the front panel numeric keyboard to enter the numbers. You will see your entry in the active function area. When you have completed entering the license key number, press **Enter**.

---

**NOTE**

It is very important to enter the number accurately. Since it is a hexadecimal, the letter “O” can not be present, only zeros are used in the license key number.

---

- c. After you have entered the option designator and the license key number, press **Activate License**.

**Step 4: Loading Firmware for Measurement Options (if needed)**

- a. Refer to [Chapter 13](#), “[Firmware Upgrades](#).” Since the replacement Flash board does not come preloaded with all possible options, you must load the option FW at this time. It may be necessary to enter an IP address when down loading the firmware. See step 5.
- b. The options will now be available. Press **System, Show System** to assure the options have been loaded.

**Step 5: Entering the IP Address and Host Name**

- a. To enter the IP address, press **System, Config I/O, IP Address**. Type in the address and press **Enter**.
- b. To enter the Host Name, press **Host Name**. Type in the host name and press **Enter**.
- c. To enter the Subnet Mask, press **Subnet Mask**. Type in the subnet mask, then press **Enter**.
- d. To enter the Default Gateway, press **Default Gateway**. Type in the default gateway, then press **Enter**.
- e. The Flash configuration is now complete.

**What to do if the instrument is non-functional and the configuration data cannot be obtained from the instrument screen**

Determine what options should be present:

The serial tag on the rear panel contains a list of the options that were present when Agilent shipped the instrument. The option designators can be found here. The serial tag may only provide a partial list since options are retrofitted in the field.

Contact the instrument owner and ask them if they have license keyword certificates for their instrument. These certificates are sent with all field retrofit kits and list the option name and the license keyword.

Contact an Agilent sales and service office for configuration and licensing information for your instrument. See [page 37](#).



## Firmware Upgrades Including Measurement Personality Upgrades

The PSA Firmware Update Program requires a PC and a LAN connection to your instrument. Instruments without an IP address, or a PC not connected to the same subnet as the instrument require a crossover cable. A crossover cable is a CAT, RJ-45 cable with cross pinning. The Agilent p/n is 8121-0545. These cables are available at computer stores also.

### Instructions:

1. Go to the PSA Product Page:

<http://www.agilent.com/find/psa/>

2. Click on “PSA Firmware Updates”.
3. Click on “PSA Series Firmware Upgrade A.XX.XX” and follow the instructions.

### Re-installation of Firmware Procedure following Secure Erase All (Option 117)

1. Load the PSA Series Firmware Update Program from the following Agilent Web site:  
  
[http://www.agilent.com/find/psa\\_firmware](http://www.agilent.com/find/psa_firmware)
2. At the menu screen, click on Troubleshooting Wizard, click on Recovery, then click Next.
3. Under “The PC Update Program was Interrupted”, click Next. The “Non-Functional Instrument Procedure” will appear. Follow this procedure.

---

**NOTE** The Ethernet Number becomes the hardware address when the hyphen is removed (i.e. Ethernet Number 001083-b80c55 becomes hardware address 001083b80c55). If you have access to this previously saved address, enabling the external keyboard step in the procedure can be skipped.

---

**NOTE** Enter the path for “Restore the Configuration and User Data” when prompted. In a service situation this may not be possible since the PC containing these files is the PC that was used during the last instrument firmware upgrade.

The PSA user data, options, and license keys are saved in a file named ‘Config’ under a directory that begins with the model number, followed by the serial number, then a date and time stamp on the C: drive of the PC; for example,  
“C:\E4448A\US42070187\15-Oct-02-11-29-AM\Config”.

---

**NOTE** If a configuration back-up file is not available, the License Keys are needed to enable the options once the firmware is re-installed. You will be unable to determine which measurement personalities were loaded into the instrument and all license keywords have been erased. Contact an Agilent Sales or Service Office for assistance obtaining this information. Please have the instrument serial number and instrument Host ID number available before contacting Agilent.

---

Firmware Upgrades

**Firmware Upgrades Including Measurement Personality Upgrades**



---

# Index

---

## Symbols

+, 79

## Numerics

10 MHz OUT (SWITCHED) rear  
panel connector, 164  
10 MHz Out key, 64  
10 MHz output description, 119  
100 MHz VCXO, 119, 120  
1DS option, 74, 94  
1st LO state, 61  
21.4 MHz anti-alias filter  
description, 134  
2ND IF OUT rear panel  
connector, 164  
30 MHz sample clock, 150  
300 MHz outputs, 119  
321.4 MHz cal signal mixer, 128  
321.4 MHz filters, 127  
50 MHz calibrator, 119  
50 MHz calibrator ALC, 127  
50 MHz oscillator key, 59  
600 MHz outputs, 119  
7.5 MHz IF description, 139

## A

A1 flat panel display  
description, 159  
part number, 224  
parts, 296  
removal, 399  
troubleshooting, 160  
A10 third converter assembly, 72,  
92  
description, 127  
interconnections, 128  
part number, 224  
removal, 371  
troubleshooting, 129, 131  
A11 reference assembly  
description, 118  
interconnections, 119  
part number, 224  
removal, 371  
troubleshooting, 120  
A12 synthesizer assembly  
description, 113  
part number, 224  
removal, 371  
troubleshooting, 114  
A12A1 LO/synthesizer board  
part number, 224  
A12A2 sampling oscillator board  
part number, 224  
A13 front end driver board  
description, 84, 107

part number, 224  
removal, 371  
troubleshooting, 84, 107  
A14 input attenuator  
part number, 224  
settings, 77, 97  
troubleshooting, 76, 96  
A15 input attenuator  
part number, 224  
settings, 77, 97  
troubleshooting, 76, 96  
A18 YTO  
part number, 224  
removal, 322, 341  
troubleshooting, 81, 103  
A19 RYTHM  
part number, 224  
removal, 322  
troubleshooting, 80  
A19 SBTX/RYTHM  
removal, 341  
A19 SBTX/RYTHM assembly, 91  
A2 front panel interface board  
description, 159  
part number, 224  
removal, 402  
troubleshooting, 160  
A20 lowband assembly, 71, 92  
part number, 224  
removal, 324, 343  
troubleshooting, 82, 104  
A21 FELOMA  
part number, 224  
removal, 342  
troubleshooting, 98  
A21 SLODA  
part number, 224  
removal, 323  
troubleshooting, 78  
A22 preamplifier assembly  
part number, 224  
removal, 326, 347  
troubleshooting, 86, 108  
A23 disk drive  
description, 159  
part number, 224  
parts, 297  
removal, 378  
A25 motherboard  
description, 147  
part number, 224  
removal, 382  
A26 processor assembly  
description, 148  
part number, 224  
parts, 302, 303  
removal, 385

troubleshooting, 149  
A26A1 DRAM board, 149, 423  
part number, 224  
removal, 388  
A26A2 Flash memory board, 149,  
423  
configuring, 425  
part number, 224  
removal, 388  
replacement, 426  
A27 electronic attenuator  
part number, 224  
removal, 326, 347  
troubleshooting, 87, 109  
A28 audio out board  
part number, 224  
A29 SBTX Driver board  
part number, 224  
removal, 345  
A2A1 top inverter board  
part number, 224  
removal, 402  
troubleshooting, 160  
A2A2 bottom inverter board  
part number, 224  
removal, 402  
troubleshooting, 160  
A3 keyboard assembly  
description, 159  
part number, 224  
removal, 404  
A30 FIFA assembly  
part number, 224  
removal, 345  
A33 70 MHz Output assembly  
description, 164  
part number, 224  
A39 USB/Memory board  
removal, 363  
A5 power supply  
description, 153  
part number, 224  
removal, 361, 363  
troubleshooting, 154  
A6 SCSI board  
description, 158  
part number, 224  
removal, 366  
A7 digital IF assembly  
description, 139  
interconnections, 140  
part number, 224  
removal, 371  
troubleshooting, 141  
A8 analog IF assembly  
description, 133  
interconnections, 135

---

# Index

---

- part number, 224
  - removal, 371
  - troubleshooting, 136
  - A9 second LO/fan control
    - assembly
    - description, 122
    - interconnections, 122
    - part number, 224
    - removal, 371
    - troubleshooting, 123
  - ADC
    - control, 60
    - range, 60
  - adjustment software
    - see performance verification tests
  - adjustments
    - equipment, 24
    - required test equipment, 24
    - test equipment, 24
  - after repairs
    - see post-repair procedures, 412
  - Agilent Technologies
    - contacting, 37
    - Sales and Service offices, 37
  - Align All Now, 63, 112
  - Align Current IF Flatness key, 63
  - Align Current Sysgain key, 63
  - align defaults, 63
  - Align Subsys key, 63
  - alignment features, 62
  - Alignments key, 45
  - analog IF
    - see A8 analog IF assembly
  - APC 3.5 mm input connector, 74
  - assemblies, major, 252, 309
  - assembly part numbers, 225
  - attenuator assembly (E4440A, E4443A, E4445A)
    - removal, 357
  - attenuator assembly (E4446A, E4448A)
    - removal, 359
  - attenuators, 71, 91
  - audio out board
    - see A28 audio out board
  - auto align, 62
  - auto align tests, 49
  - auto boot, 150
  - Auto Peak key, 60
  - Auto Peak Lock key, 60
  - AYZ option, 74, 94
- B**
- B1, B2, B3 fans
    - part number, 224
    - removal, 374
  - B7J option, 74, 94
  - BAB option, 74
  - band lock, 58
  - band pass filter, 71, 92
  - band switch, 79
  - basics, troubleshooting, 45
  - battery, 36, 152, 387
  - bezel, removal, 404
  - blank LCD, 46
  - Block Diagrams, 212
  - boot problems, 46
  - boot process, 46, 48, 149
  - burp mode, 155
  - burst trigger check, 419
- C**
- cable part numbers, 236
  - calibrator oscillator description, 134
  - clearing error queue, 57
  - clock generator description, 134
  - clock measurements, 142
  - configuration information, 423, 426
  - configure a replacement CPU, 422
  - configure a replacement Flash memory assembly, 425
  - contacting Agilent, 37
  - CPU assembly
    - configuring, 422
    - see A26 processor assembly
  - critical data, 422
- D**
- DC block, 71
  - dead instrument,
    - troubleshooting, 47
  - diagnostic routines, 58
  - diagnostics, 59, 64
  - digital demod hardware, 74, 94
  - digital IF
    - see A7 digital IF assembly
  - display
    - see A1 flat panel display
  - display filter
    - removal, 401
  - display parts, 398
  - display problem, 47
  - down conversion, 72, 92
  - DRAM
    - see A26A1 DRAM board
  - dual loop troubleshooting, 116
- E**
- electronic attenuator
    - see A27 electronic attenuator
  - electrostatic discharge, 19
  - entering
    - serial number, 424
  - entering configuration information, 423
  - equipment
    - adjustments, 24
    - performance verification tests, 24
  - error messages, 45, 57
  - error queue, 57
    - clearing, 57
  - ESD Information, 19
  - EXT REF IN rear panel connector, 164
  - extender board
    - e4440-60049, 115, 116
  - external hardware, 249
  - external mixing, 74, 94
  - external monitor, 160
  - external trigger
    - front panel connector removal, 407
- F**
- fan voltages, 123
  - fans
    - problem, 47
    - see B1, B2, B3 fans
    - troubleshooting, 123
    - voltages, 123
  - FELOMA
    - see A21 FELOMA assembly
  - FIFA
    - see A30 FIFA assembly
  - firmware, 45
  - firmware updating, 430
  - first LO state, 61
  - first mixer, 71, 92
  - FL1 low pass filter
    - removal, 323, 342
  - FL2 band pass filter, 71, 92
    - removal, 324, 343
  - Flash
    - see A26A2 Flash memory board
  - flatness, 58
  - fourth LO description, 134
  - Freq Ref key, 64
  - frequency reference, 64
  - frequency response, 58
  - front end driver board
    - see A13 front end driver board
  - front end troubleshooting, 75, 95
  - front frame
    - description, 159
    - hardware, 251
    - removal, 314
-

---

# Index

---

- front frame shield
  - removal, [395](#)
- front panel assemblies, [295](#)
- front panel connectors part numbers, [247](#)
- front panel interface
  - see [A2 front panel interface board](#)
- front panel keys, [57](#)
- front panel parts, [292](#)
- front panel shield hardware, [294](#)
- front panel test, [64](#)
- functional tests, [45](#)
- fuse, [154](#)
  
- G**
- gain range select description, [139](#)
  
- H**
- H70
  - see [A33 70 MHz Output Assembly](#)
- hardware
  - external, [249](#)
  - front frame, [251](#)
  - front panel shield, [294](#)
  - rear frame, [298](#)
  - RF input connector (E4440A, E4443A, E4445A), [258](#)
  - RF input connector (E4446A, E4448A), [274](#)
  - top brace, [250](#)
- high band path, [71](#)
- host name, [427](#)
- HSYNC, troubleshooting, [162](#)
  
- I**
- IF control, [59](#)
- individual voltage supplies, [155](#)
- initial symptoms, [46](#)
- inoperative instrument, troubleshooting, [47](#)
- input attenuators, [71](#), [91](#)
  - see [A14 and A15 input attenuator](#)
- input signal check
  - [A12 synthesizer assembly](#), [114](#)
- installing measurement personalities, [426](#)
- instrument packaging, [40](#)
- instrument serial number, [39](#)
- internal calibrator signals, [53](#)
- internal diagnostic routines, [58](#)
- internal front panel test, [420](#)
- inverter boards
  - see [A2A1 and A2A2 inverter boards](#)
- IP address, [427](#)
  
- K**
- keyboard
  - see [A3 keyboard assembly](#)
  
- L**
- LAN, [150](#)
- LCD
  - see [A1 flat panel display](#)
- LCD clock, troubleshooting, [162](#)
- LED
  - front panel, [45](#), [46](#), [154](#)
  - rear panel, [46](#), [150](#)
  - sequence, [48](#)
- License key, [426](#)
- license key number, [422](#), [426](#)
- linearization circuit, [127](#)
- LO null, [59](#)
- LO unlevelled error, [78](#), [98](#)
- LO/synthesizer board
  - see [A12A1 LO/synthesizer assembly](#)
- loading measurement option
  - firmware, [427](#)
- low band path, [71](#)
- low band preamp, [74](#), [94](#)
- lowband
  - see [A20 lowband assembly](#)
  
- M**
- main gain amplifier description, [133](#)
- major assemblies, [252](#), [309](#)
- measurement option firmware, [427](#)
- measurement personality
  - updating, [430](#)
- mechanical part numbers, [231](#)
- mid web
  - parts, [300](#)
  - removal, [376](#)
- mixer, [71](#), [92](#)
- mixer (A8 analog IF) description, [134](#)
- monitor, external, [160](#)
  
- N**
- noise source, [59](#)
  
- O**
- offset adjust and dither
  - description, [139](#)
  
- option
  - 1DS, [74](#), [94](#)
  - AYZ, [74](#), [94](#)
  - B7J, [74](#), [94](#)
  - BAB, [74](#)
  - Option 123
    - cables, [264](#)
  - original instrument packing, [40](#)
  - other instrument packing, [41](#)
  - outer case, removal, [310](#)
  - over voltage, [155](#)
  - overview, PSA spectrum analyzer, [15](#)
  
- P**
- packaging, [40](#)
- parts
  - list, [221](#)
  - replaceable, [224](#)
- password, [58](#)
- performance tests
  - troubleshooting, [65](#)
- performance verification tests
  - equipment, [24](#)
  - required test equipment, [24](#)
  - software, [36](#)
  - test equipment, [24](#)
- personality updating, [430](#)
- phase lock circuitry, [120](#)
- post down conversion filter
  - description, [134](#)
- post-repair procedures, [412](#)
- power supply
  - see [A5 power supply](#)
- power supply switching frequency generator description, [135](#)
- power-on process, [149](#)
- power-up problems, [46](#)
- pre-filter description, [133](#)
- PRE-SEL OUT rear panel connector, [164](#)
- probe power connector, [154](#)
  
- R**
- real time clock, [152](#), [387](#)
- rear frame
  - hardware, [298](#)
  - removal, [390](#)
- rear panel connectors, [149](#)
  - see [individual connectors](#)
- rear panel description, [164](#)
- reference
  - see [A11 reference assembly](#), [224](#)
- reference unlock detector
  - description, [119](#)
- remove
  - see [individual assemblies](#)

---

# Index

---

- replace
  - see individual assemblies
- replaceable parts, 224
- replacement processor, 149
- required test equipment
  - adjustments, 24
  - performance verification tests, 24
  - troubleshooting, 24
- Restore Align Defaults key, 63
- Restore Sys Defaults key, 64
- returning instrument for service, 40
- RF input connector (E4440A, E4443A, E4445A)
  - hardware, 258
  - part number, 224
  - removal, 393
- RF input connector (E4446A, E4448A)
  - hardware, 274
  - part number, 224
  - removal, 393
- RF section
  - assemblies, 254, 268, 320, 339
  - cables, 260, 262, 266, 276, 278, 280
  - description, E4440A, E4443A, E4445A, 71
  - description, E4446A, E4448A, 91
  - option assemblies, 325, 346
  - quick check troubleshooting, 75, 95
- RF section (E4440A, E4443A, E4445A)
  - removal, 317
- RF section (E4446A, E4448A)
  - removal, 336
- ribbon cables, 290, 291
- RPG, removal, 407
- RYTHM
  - see A19 RYTHM
- S**
- Safety Information, 3, 307
- Sales and Service offices, 37
- sample clock, 150
- sampler error, 78, 98
- sampling oscillator board
  - see A12A2 sampling oscillator board
- SBTX Driver board
  - see A29 SBTX Driver Board
- SBTX/RYTHM
  - see A19 SBTX/RYTHM
- SCSI board
  - see A6 SCSI board
- second LO/fan control
  - see A9 second LO/fan control assembly, 224
- second mixer, 71, 92
- serial number, 39
  - entering, 424
- service
  - equipment, 22
  - how to return your analyzer, 40
  - key, 58
  - kit, 22, 75, 95
  - password, 58
  - tag, 40
  - tools, 308
- signal mnemonics, 209
- single loop troubleshooting, 116
- specifications, 45
- static damage, 19
- static safe accessories, 20
- step attenuators
  - A10 third converter assembly, 127
- support URL, 37
- support web site, 37
- synthesizer
  - see A12 synthesizer assembly
- system defaults, restoring, 64
- system variable gain, 58
- T**
- test and adj. software
  - see performance verification tests
- test equipment
  - adjustments, 24
  - performance verification tests, 24
  - post-repair, 411
  - troubleshooting, 24
- test software
  - see performance verification tests
- thermal shutdown, 123
- third converter
  - see A10 third converter assembly, 224
- third mixer, 128
- top brace
  - hardware, 250
  - removal, 312
- TRIGGER IN rear panel connector, 164
- TRIGGER OUT (1 + 2) rear panel connectors, 164
- troubleshooting
  - attenuators, 76, 96
  - auto align, 49
  - basics, 45
  - before troubleshooting, 19
  - electronic attenuator, 87, 109
  - equipment needed, 24
  - FELOMA, 98
  - front end, 75, 95
  - front end driver, 84, 107
  - front panel keys, 57
  - initial checks, 47
  - inoperative instrument, 47
  - internal calibrator signals, 53
  - lowband assembly, 82, 104
  - performance test failures, 65
  - preamp, 86, 108
  - problems at power-up, 46
  - RF assembly quick check, 75, 95
  - RYTHM, 80
  - SBTX, 101
  - SBTX driver, 98
  - see individual assemblies
  - SLODA, 78
  - symptoms, 46
  - YTO, 81, 103
- U**
- unlock conditions, 114
- updating firmware, 430
- updating measurement personalities, 430
- URL, 37, 45
- user diagnostics, 64
- V**
- variable gain, 58
- variable gain compensation circuitry, 127
- VCXO, 120
- vertical board assemblies, removal, 371
- vertical board assembly cables, 282, 284, 368
- VGA monitor, 160
- VSYNC, troubleshooting, 162
- W**
- web site URL, 45
- Y**
- YTO
  - assemblies, 256
  - see A18 YTO
- YTO unlock error, 78, 98